

**МИНИСТЕРСТВО ЦИФРОВОГО РАЗВИТИЯ,  
СВЯЗИ И МАССОВЫХ КОММУНИКАЦИЙ РОССИЙСКОЙ ФЕДЕРАЦИИ**

**ФЕДЕРАЛЬНОЕ ГОСУДАРСТВЕННОЕ БЮДЖЕТНОЕ ОБРАЗОВАТЕЛЬНОЕ  
УЧРЕЖДЕНИЕ ВЫСШЕГО ОБРАЗОВАНИЯ**

**«САНКТ-ПЕТЕРБУРГСКИЙ ГОСУДАРСТВЕННЫЙ УНИВЕРСИТЕТ  
ТЕЛЕКОММУНИКАЦИЙ ИМ. ПРОФ. М.А. БОНЧ-БРУЕВИЧА»  
(СПбГУТ)**

**Санкт-Петербургский колледж телекоммуникаций им. Э.Т. Кренкеля**

---

УТВЕРЖДАЮ

Заместитель директора

по учебной работе

В.В. - Н.В. Калинина

17 марта 2022 г

**МЕТОДИЧЕСКИЕ УКАЗАНИЯ ПО ВЫПОЛНЕНИЮ  
ПРАКТИЧЕСКИХ РАБОТ**

по учебной дисциплине

**ОГСЭ.03. ИНОСТРАННЫЙ ЯЗЫК В ПРОФЕССИОНАЛЬНОЙ ДЕЯТЕЛЬНОСТИ**

по специальности

10.02.04 Обеспечение информационной безопасности телекоммуникационных систем

среднего профессионального образования

Санкт-Петербург  
2022

**ОГСЭ.03 Иностранный язык в профессиональной деятельности.** Методические указания по выполнению практических работ.

Составил Е.И. Захарычева. – Санкт-Петербург, 2022.

Методические указания содержат описания практических занятий, предусмотренных рабочей программой **ОГСЭ.03 Иностранный язык в профессиональной деятельности**. Каждая работа рассчитана на 2 академических часа, общий объём составляет 164 часа. Нумерация рисунков, формул и таблиц в пределах одной работы. Методические указания предназначены для обучающихся очной формы обучения по специальности 10.02.04 Обеспечение информационной безопасности телекоммуникационных систем

Рассмотрено и одобрено предметной (цикловой) комиссией Иностранных языков Санкт-Петербургского колледжа телекоммуникаций им. Э.Т. Кренкеля.

## СОДЕРЖАНИЕ

<b>3 семестр.</b>	<b>7</b>
<b>Практическое занятие №1, Система образования в России</b>	<b>7</b>
<b>Практическое занятие №2, Система образования в Великобритании</b>	<b>9</b>
<b>Практическое занятие 3, Система образования в США</b>	<b>11</b>
<b>Практическое занятие № 4 Сравнение систем образования в России, США и Великобритании.</b>	<b>12</b>
<b>Практическое занятие 5. Виртуальная школа</b>	<b>16</b>
<b>Практическое занятие 6, Написание мотивационного письма</b>	<b>17</b>
<b>Практическое занятие 7, Мое расписание</b>	<b>19</b>
<b>Практическое занятие 8, Мой колледж</b>	<b>20</b>
<b>Практическое задание 9, Магазины</b>	<b>22</b>
<b>Практическое задание 10, Покупки</b>	<b>22</b>
<b>Практическое задание 11, Посещение достопримечательностей.</b>	<b>25</b>
<b>Практическое занятие 12, Хобби</b>	<b>26</b>
<b>Практическое занятие 13, Необычные хобби в разных странах</b>	<b>30</b>
<b>Практическое занятие №14, Чтение. Литературные жанры</b>	<b>32</b>
<b>Практическое занятие №15, Кино. Жанры кино</b>	<b>34</b>
<b>Практическое занятие №16. Обобщение лексического и грамматического материала.</b>	<b>37</b>
<b>4 семестр</b>	<b>37</b>
<b>Практическое занятие 1. Здоровое питание.</b>	<b>37</b>
<b>Практическое занятие 2. Посещение ресторана.</b>	<b>40</b>
<b>Практическое занятие 3. Готовим дома: рецепт любимого блюда.</b>	<b>42</b>
<b>Практическое занятие 4. Болезни и их лечение</b>	<b>43</b>
<b>Практическое занятие 5. Болезни и их лечение.</b>	<b>45</b>
<b>Практическое занятие 6. Посещение врача.</b>	<b>49</b>
<b>Практическое занятие 7. Спорт. Виды спорта.</b>	<b>51</b>
<b>Практическое занятие 8. Мой любимый вид спорта.</b>	<b>53</b>
<b>Практическое занятие 9. Спорт в России и Великобритании. Выдающиеся спортсмены.</b>	<b>57</b>
<b>Практическое занятие 10. Обобщение лексического и грамматического материала.</b>	<b>61</b>

Практическое занятие 11. Виды транспортных средств.	63
Практическое занятие 12. Советы путешественнику.	64
Практическое занятие 13. Отправляемся в путешествие: бронируем номер в отеле.	67
Практическое занятие 14. Плюсы и минусы разных транспортных средств.	70
Практическое занятие 15. Проблемы во время путешествий и их решение.	74
Практическое занятие 16. Диалоги в аэропорту и на вокзале.	75
Практическое занятие 17. Диалоги в незнакомом городе.	77
Практическое занятие 18. Осмотр достопримечательностей.	80
Практическое занятие 19. Достопримечательности Санкт-Петербурга.	82
Практическое занятие 20. Экскурсия в мой родной город.	84
Практическое занятие 21. Обобщение лексического материала.	86
Практическое занятие 22. Обобщение грамматического материала.	87
<b>5 семестр</b>	88
Практическое занятие 1. Компьютеры в повседневной жизни	88
Практическое занятие 2. Жизнь в цифровую эпоху	92
Практическое занятие 3. Пользователи компьютеров	94
Практическое занятие 4. Что такое компьютер?	98
Практическое занятие 5. Типы компьютеров	100
Практическое занятие 6. Устройства ввода. Устройства ввода: клавиатура и мышь	104
Практическое занятие 7. Устройства вывода: принтеры и их типы. Устройства вывода: монитор	109
Практическое занятие 8. Устройства хранения: магнитные накопители	115
Практическое занятие 9. Оптические устройства хранения	119
Практическое занятие 10. Флеш-память	125
Практическое занятие 11. Введение в программное обеспечение	131
Практическое занятие 12. Типы операционных систем	133
Практическое занятие 13. Сравнительная характеристика операционных систем	137
Практическое занятие 14. Обобщение лексического и грамматического материала	140
<b>6 й семестр</b>	149
Практическое занятие №1. Типы интерфейсов	149

Практическое занятие 2. GUI	151
Практическое занятие 3. Введение в программирование	154
Практическое занятие 4. Языки программирования	158
Практическое занятие 5. Понятие сети	160
Практическое занятие 6. Сети и их типы.	165
Практическое занятие 7. Проводные и беспроводные компьютерные сети.	171
Практическое занятие 8. Топология беспроводных и проводных сетей.	172
Практическое занятие 9. Физическая передающая среда (коаксиальный кабель, витая пара, оптоволокно).	177
Практическое занятие 10. Современные технологии коммуникации.	183
Практическое занятие 11. Интернет	186
Практическое занятие 12. Всемирная сеть	188
7 семестр	191
Практическое занятие 1. ПРЕДПОСЫЛКИ ДЛЯ УСПЕШНОЙ КАРЬЕРЫ	191
Практическое занятие 2. ПРОДОЛЖИТЬ УЧЕБУ ИЛИ ПОЙТИ РАБОТАТЬ? ПРОГРАММЫ ОБМЕНА.	193
Практическое занятие 3. ЗАПОЛНЕНИЕ АНКЕТЫ АБИТУРИЕНТА.	194
Практическое занятие 4. РАБОТА В БОЛЬШОЙ КОМПАНИИ ИЛИ ФРИЛАНС: ПЛЮСЫ И МИНУСЫ.	195
Практическое занятие 5. РАБОТА МОЕЙ МЕЧТЫ.	197
Практическое занятие 6. ОПЫТ БЫВШЕГО СТУДЕНТА.	197
Практическое занятие 7. ПРОФЕССИИ В ОБЛАСТИ ИНФОРМАЦИОННЫХ ТЕХНОЛОГИЙ.	199
Практическое занятие 8. ОБЪЯВЛЕНИЕ О ПРИЕМЕ НА РАБОТУ.	202
Практическое занятие 9. СОСТАВЛЕНИЕ РЕЗЮМЕ.	204
Практическое занятие 10. СОСТАВЛЕНИЕ СОПРОВОДИТЕЛЬНОГО ПИСЬМА.	207
Практическое занятие 11. ПРОХОЖДЕНИЕ СОБЕСЕДОВАНИЯ	208
Практическое занятие 12. ВЫСТУПЛЕНИЕ НА КОНФЕРЕНЦИИ, ВЕДЕНИЕ ДИАЛОГА	212
Практическое занятие 13. ЧТЕНИЕ И ПЕРЕВОД ТЕКСТОВ. МОНОЛОГИЧЕСКАЯ, ДИАЛОГИЧЕСКАЯ РЕЧЬ	216
Практическое занятие 14. ОФИЦИАЛЬНАЯ И НЕОФИЦИАЛЬНАЯ ПЕРЕПИСКА	218



**3 семестр.**

## **Практическое занятие 1**

### **Система образования в России**

**1. Цель:** Развитие умений чтения с извлечением необходимой информации

**2. Задачи:**

- закрепление и систематизация теоретических знаний по лексической теме;
- совершенствование навыков чтения и перевода текста на иностранном языке;
- самостоятельное совершенствование письменной речи;
- дальнейшее развитие умений общаться на иностранном языке на повседневные темы;
- совершенствование навыков поиска информации.

**3. Подготовка к работе:**

Повторение слов по теме “Образование”

**4. Задание:**

**Задание 1. Прочитайте текст, поймите основное содержание и подберите к каждому абзацу соответствующий заголовок из предложенных ниже.**

- A) What Is Education?
- B) Formal Education
- C) General Education
- D) Informal Education
- E) Vocational Education
- F) Different Kinds of Formal Education

### **DIFFERENT TYPES OF EDUCATION**

1. Education includes different kinds of learning experiences. In its broadest sense, education is the ways in which people learn skills, gain knowledge and understanding about the world and themselves. A useful scheme for discussing education is to divide these ways of learning into two types: informal and formal.

2. Informal education involves people in learning during their daily life. For example, children learn their language simply when they listen to others and try to speak themselves. In the same informal manner, they learn to dress themselves, to eat with good manners, to ride a bicycle, or to make a telephone call. Education is also informal when people try to get information or to learn skills on their own initiative without a teacher. They may visit a book shop, library or museum. They may watch TV or listen to the radio. A lot of documentary and educational films and programmes can be watched in the Internet. People do not have to take tests or exams getting informal education.

3. The learners get formal education at different kinds of schools, colleges, universities. In most countries, people enter a system of formal education during their early childhood. In this type of education, people who are in charge of education decide what to teach. Then learners are studying these things with the teachers' help. Learners should come to school regularly and on time and try to work at about the same speed as their classmates. Learners have to take tests and exams. At the end of their learning, learners may earn a diploma, a certificate, or a degree as a mark of their success over the years.

4. The school systems of all modern nations provide both general and vocational education. Most countries also offer special education programmes for gifted and for physically or mentally handicapped children. Adult education programmes are provided for people who wish to take up their education after leaving school. Most countries are spending a large amount of time and money for formal education of their citizens.

5. The aim of general education is to make children intelligent, responsible, well-informed citizens. It is designed to transmit a common cultural heritage rather than to develop trained specialists. Almost all elementary education is general education. In every country, primary school pupils are being taught skills they will use throughout their life, such as reading, writing, and arithmetic. They also receive instruction in different subjects, such as geography, history, etc. In most countries almost all young people continue their general education in secondary schools.

6. The aim of vocational education is primarily to prepare students for a job. Some secondary schools specialize in vocational programmes. Technical schools are vocational secondary schools, where students are being taught more technical subjects, such as carpentry, metalwork, and electronics. Technical school students take some general education courses and vocational training. Universities and separate professional schools are preparing students for careers in such fields as agriculture, architecture, business, engineering, law, medicine, music, teaching, etc.

### **Задание 2. Согласитесь или не согласитесь со следующими утверждениями**

1. There are two types of education. 2. A useful scheme for discussing education is to divide the ways of learning into two types. 3. Informal education involves people in learning during their daily life. 4. Formal education is given at different kinds of colleges. 5. General education is designed to develop trained specialists.

### **Задание 3. Прочитайте текст и выполните задания.**

#### **Education in Russia**

1. Every citizen of this country has the right to education. This right is guaranteed by the Constitution. It is not only a right but a duty, too. Every boy or girl must get secondary education. They go to school at the age of the six or seven and must stay there until they are 14-17 years old. At school, pupils study academic subjects, such as Russian, Literature, Mathematics, History, Biology, a foreign language and others.

2. After finishing 9 forms of a secondary school young people can continue their education in the 10th and 11th form. They can also go to a vocational or technical school, where they study academic subjects and receive a profession. A college gives general knowledge in academic subjects and a profound knowledge in one or several subjects.

3. After finishing a secondary, vocational, technical school or college, young people can start working or enter a university or an academy. Universities and academies train specialists in different fields. A course at a university usually takes 5 years. Many universities and academies have part-time and correspondence departments. They give their students an opportunity to study without leaving their jobs. Universities and academies have post-graduate courses, which give candidate or doctoral degrees.

4. Education in this country is free at most school. There are private primary and secondary schools where pupils have to pay for their studies. Students of universities and academies get scholarships. At many universities and academies there are also departments at which students have to pay for their education.

### **Ответьте на вопросы к тексту**

- 1) How is the right to education in Russia guaranteed?
- 2) Why is education a duty?
- 3) At what ages must Russian children stay at school?



- 4) What subjects do pupils study at school?
- 5) What can pupils do after finishing 9 forms at a secondary school?
- 6) What is the difference between a vocational or technical school and college?
- 7) What can young people do after finishing the 11th form at a secondary school?
- 8) What departments do many higher educational institutions have?
- 9) What is a post-graduate course? Who can take it?
- 10) Do pupils and students in this country have to pay for education?

### 5. Порядок выполнения работы

Прочитать и перевести текст, выделить и записать новые слова, ответить на вопросы по тексту, выполнить задание в группах, фронтальное обсуждение

### 6. Содержание отчета

Конспект

## Практическое занятие №2, Система образования в Великобритании

**1. Цель:** Развитие умений чтения с извлечением необходимой информации

**2. Задачи:**

- закрепление и систематизация теоретических знаний по лексической и грамматическим темам;
- совершенствование навыков чтения и перевода;
- Закрепление знаний и навыков оформления официальных писем.

**3. Подготовка к работе:**

Повторение слов по теме “Образование”

**4. Задание:**

**Задание 1. Прочитайте текст, заполните пропуски (1-6) недостающими частями предложений, которые даны после текста (a-f). В тетрадях запишите цифру и букву, выбранного варианта.**

### Education in Britain

In England and Wales compulsory school begins at the age of five, but before that age children can go to a nursery school, 1)\_\_\_\_\_ . School is compulsory till the children are 16 years old.

In Primary School and First School children learn to read and write and the basis of arithmetic. In the higher classes of Primary School (or in Middle School) children

2) \_\_\_\_\_ schools, a foreign language. Then children go 3) \_\_\_\_\_.

When students are 16 years old they may take an exam in various subjects in order to have a qualification. These qualifications can be either G.C.S.E. (General Certificate of Secondary Education) or "O level" (Ordinary level). After that students

4) \_\_\_\_\_ as before. If they continue, when they are 18, they have to take further examinations which are necessary for getting into university or college.

Some parents choose private schools for their children. They are 5) \_\_\_\_\_.

In England there are 47 universities, including the Open University which teaches via TV and radio, about 400 colleges and institutes of higher education. The oldest universities in England are Oxford and Cambridge. Generally, universities award two kinds of degrees: 6) \_\_\_\_\_.

- a) very expensive but considered to provide a better education and good job opportunities.
- b) to the Secondary School.
- c) the Bachelor's degree and the Master's degree.
- d) can either leave school and start working or continue their studies in the same school
- e) learn geography, history, religion and, in some
- f) also called play school

1. Ответьте на вопросы по содержанию текста

- 7) When does compulsory school begin?
- 8) How long does a child stay in compulsory school?
- 9) What subjects do children learn in Primary School?
- 10) What kind of exam do students have to take when they are 16?
- 11) Do students have to leave school at the age of 16 or to continue their studies?
- 12) How do private schools differ from the regular ones?
- 13) How many universities are there in England?
- 14) What is the Open University?
- 15) What kinds of degrees do universities award?

## 5. Порядок выполнения работы

Прочитать и перевести текст, выделить и записать новые слова, ответить на вопросы по тексту, выполнить задание в группах, фронтальное обсуждение

## 6. Содержание отчета

Конспект

## Практическое занятие 3, Система образования в США

**1. Цель:** Развитие умений чтения с извлечением необходимой информации

**2. Задачи:**

- закрепление и систематизация теоретических знаний по лексической и грамматическим темам;
- обобщение лингвострановедческих и социокультурных знаний.

**3. Подготовка к работе:**

Повторение слов по теме “Образование”

**4. Задание:**

**Задание 1. Прочитайте текст про систему образования в США. Изучите лексику после текста.**

The system of education in the United States is rather complicated. It is exposed to the constant changes of federal policies, adaptation to various social needs, and the emergence of new pedagogical methods.

In most schools, it is divided into three levels:

- elementary school – grades 1 to 5,
- middle school — grades 6 to 8,
- high school — grades 9 to 12.

This 12-year system is called “K-12”. K-12 stands for the grades for students of various age groups from the kindergarten age (5 years old) to the 12th grade age (18 years old).

There are three types of schools in the United States: public, private, and home schools. Public schooling is financed by federal, state, and local authorities. Parents do not pay for their children’s education. Private schools have a right to choose their curriculum and establish their policies. This kind of education is not free of charge. Homeschooling addresses the needs of parents who do not want their children to attend regular schools for certain reasons. Among home school students are children with special needs and children whose parents support non-traditional methods of learning. There are also young athletes and celebrities whose tight schedule do not leave them enough time for going to school. About 3% of children are homeschooled in the USA.

The necessary standards of education in the United States are set by state governments. As a rule, the key requirement for American students is to pass obligatory standardized tests developed for the K-12 schooling system.

After high school, children have several options. First, they can choose a 4-year college or university program and get the education for the selected professional career. Second, children can choose a 2-year program in college and get prepared for their future career choice. Third, high school graduates can enter a vocational school and learn a trade to have an opportunity to be employed in a specific field of occupation such as design, baking or carpentry. Fourth, graduates of high schools can choose to serve in the US armed forces.

Fifth, if children are not ready to continue their education, they can have a gap year. Most kids prefer to spend this time exploring their life preferences and individual interests through active involvement in various jobs, internships, volunteering work, or traveling.

**Задание 2. Изучите слова из текста. Придумайте предложения с ними.**

- **the system of education** – система образования
- **elementary school** – начальная школа (первые 5 классов)

- **middle school** – средняя школа (6-8 классы)
- **high school** – старшая школа (9-11 классы)
- **K-12** – условное обозначение 12-летней системы школьного образования.
- **public school** – государственная школа (бесплатная)
- **private school** – частная школа (платная)
- **homeschooling** – домашнее образование
- **children with special needs** – дети с особыми потребностями
- **non-traditional method** – нетрадиционный метод
- **tight schedule** – напряженный график
- **to pass a test** – сдать тест (пройти тест)
- **professional career** – профессиональная карьера
- **vocational school** – профессиональное учебное заведение
- **trade** – в данном случае, рабочая профессия, ремесло, одна из профессий, которым обучают в проф. училищах.
- **gap year** – «промежуточный год», т.е. год между школой и дальнейшей учебой, который дети тратят на то, чтобы лучше понять, чем они хотят заниматься в жизни (если могут себе позволить, конечно).
- **internship** – стажировка (как правило, неоплачиваемая работа ради опыта, рекомендаций)

## 5. Порядок выполнения работы

Прочитать и перевести текст, выделить и записать новые слова,, фронтальное обсуждение

## 6. Содержание отчета

Конспект

# Практическое занятие № 4 Сравнение систем образования в России, США и Великобритании.

**1. Цель:** Развитие умений чтения с извлечением необходимой информации

**2. Задачи:**

- закрепление и систематизация теоретических знаний по лексической и грамматическим темам;
- совершенствование навыков чтения и перевода.

**3. Подготовка к работе:**

Повторение слов по теме “Образование”

**4. Задание:**

**Задание 1.** Прочитайте текст, заполните пропуски (1-6) недостающими частями предложений, которые даны после текста (a-f). В тетрадях запишите цифру и букву, выбранного варианта.

### Education in Britain

In England and Wales compulsory school begins at the age of five, but before that age children can go to a nursery school, 1)\_\_\_\_\_. School is compulsory till the children are 16 years old.

In Primary School and First School children learn to read and write and the basis of arithmetic. In the higher classes of Primary School (or in Middle School) children

2) \_\_\_\_\_ schools, a foreign language. Then children go 3)

\_\_\_\_\_.  
When students are 16 years old they may take an exam in various subjects in order to have a qualification. These qualifications can be either G.C.S.E. (General Certificate of Secondary Education) or "O level" (Ordinary level). After that students

4) \_\_\_\_\_ as before. If they continue, when they are 18, they have to take further examinations which are necessary for getting into university or college.

Some parents choose private schools for their children. They are 5) \_\_\_\_\_.

In England there are 47 universities, including the Open University which teaches via TV and radio, about 400 colleges and institutes of higher education. The oldest universities in England are Oxford and Cambridge. Generally, universities award two kinds of degrees:

6) \_\_\_\_\_.

a) very expensive but considered to provide a better education and good job opportunities.

a) to the Secondary School.

b) the Bachelor's degree and the Master's degree.

c) can either leave school and start working or continue their studies in the same school

d) learn geography, history, religion and, in some

e) also called play school

## **Задание 2. Ответьте на вопросы по содержанию текста**

7) When does compulsory school begin?

7) How long does a child stay in compulsory school?

8) What subjects do children learn in Primary School?

9) What kind of exam do students have to take when they are 16?

10) Do students have to leave school at the age of 16 or to continue their studies?

11) How do private schools differ from the regular ones?

12) How many universities are there in England?

13) What is the Open University?

14) What kinds of degrees do universities award?

**Задание 3. Прочитайте текст, поймите основное содержание и подберите к каждому абзацу соответствующий заголовок из предложенных ниже.**

A) What Is Education?

B) Formal Education

C) General Education

D) Informal Education

E) Vocational Education

F) Different Kinds of Formal Education

## **DIFFERENT TYPES OF EDUCATION**

1. Education includes different kinds of learning experiences. In its broadest sense, education is the ways in which people learn skills, gain knowledge and understanding about the world and themselves. A useful scheme for discussing education is to divide these ways of learning into two types: informal and formal.

2. Informal education involves people in learning during their daily life. For example, children learn their language simply when they listen to others and try to speak themselves. In the same informal manner, they learn to dress themselves, to eat with good manners, to ride a bicycle, or to make a telephone call. Education is also informal when people try to get information or to learn skills on their own initiative without a teacher. They may visit a book shop, library or museum. They may watch TV or listen to the radio. A lot of documentary and educational films and programmes can be watched in the Internet. People do not have to take tests or exams getting informal education.

3. The learners get formal education at different kinds of schools, colleges, universities. In most countries, people enter a system of formal education during their early childhood. In this type of education, people who are in charge of education decide what to teach. Then learners are studying these things with the teachers' help. Learners should come to school regularly and on time and try to work at about the same speed as their classmates. Learners have to take tests and exams. At the end of their learning, learners may earn a diploma, a certificate, or a degree as a mark of their success over the years.

4. The school systems of all modern nations provide both general and vocational education. Most countries also offer special education programmes for gifted and for physically or mentally handicapped children. Adult education programmes are provided for people who wish to take up their education after leaving school. Most countries are spending a large amount of time and money for formal education of their citizens.

5. The aim of general education is to make children intelligent, responsible, well-informed citizens. It is designed to transmit a common cultural heritage rather than to develop trained specialists. Almost all elementary education is general education. In every country, primary school pupils are being taught skills they will use throughout their life, such as reading, writing, and arithmetic. They also receive instruction in different subjects, such as geography, history, etc. In most countries almost all young people continue their general education in secondary schools.

6. The aim of vocational education is primarily to prepare students for a job. Some secondary schools specialize in vocational programmes. Technical schools are vocational secondary schools, where students are being taught more technical subjects, such as carpentry, metalwork, and electronics. Technical school students take some general education courses and vocational training. Universities and separate professional schools are preparing students for careers in such fields as agriculture, architecture, business, engineering, law, medicine, music, teaching, etc.

#### **Задание 2. Согласитесь или не согласитесь со следующими утверждениями**

1. There are two types of education. 2. A useful scheme for discussing education is to divide the ways of learning into two types. 3. Informal education involves people in learning during their daily life. 4. Formal education is given at different kinds of colleges. 5. General education is designed to develop trained specialists.

#### **Прочитайте и переведите текст о системе образования в США**

##### **Education in the USA**

Alex, a Russian student, is talking with James Mitchell, an American from Las Vegas, Nevada. Their conversation is about the education in the USA.

— Mr Mitchell, what system of education is there in your country?

— You see, the USA has no national education system. Instead, each state is responsible for organizing and regulating its own system of education. There are common elements in the separate state systems, however.

— And what are these elements?

— Well, formal education is divided into the following stages: elementary, secondary, and higher education. School attendance is compulsory in every state.

— Are there any private schools in the USA?

— The state provides schooling at all stages of education, but parents can send their children to private schools.

— Mr Mitchell, have you got children? What school do they attend?

— Oh, Alex. I have a daughter, a nice girl, Chelsea by name. She attends a private school.

— Mr Mitchell, and what is the difference between “high schools” and “higher schools”?

— A great one. High schools, junior and senior, provide secondary education. Most of them offer both general and vocational courses of study. And higher schools provide higher learning...

— Mr Mitchell, sorry for interrupting you. At what educational institutions can one get higher education?

— Places of higher learning include community and junior colleges, technical institutes, universities, and separate professional schools.

— Thank you very much. I have a great desire to visit your country.

— You are welcome!

**Задание 4. Выберите правильный вариант ответа на следующие вопросы к текстам об образовании**

1). What stages is formal education in the USA divided into?

A general and special education

B elementary, special, adult education

C elementary, secondary, higher education

2). What stages is formal education in the UK divided into?

A primary, secondary, and further education

B secondary and vocational education

C state and private schools

3). At what age do pupils take GCSE examination in the UK?

A between the ages of 5 and 16

B at the age of 15 or 16

C at the age of 11

4). At what age do pupils take GCE examination in the UK?

A beyond the age of 16

B between the ages of 14 and 15

C beyond the age of 10

5). What kinds of schools provide secondary education in the USA?

A higher schools

B junior and senior schools

C different kinds of colleges

**Задание 5. Сравните систему образования в России, Соединенном Королевстве и США и заполните таблицу.**

**Speaking. - Поделитесь своими идеями, используя начальные фразы: to my mind, in my opinion, it seems to me, as far as I remember, etc.**

o	Questions	Russia	The UK	The USA
	Who is responsible for organizing and regulating the educational system?			
2	What stages is formal education divided into?			

3	What stages of formal education are compulsory?			
4	Are there private schools in the country?			
5	In what types of schools can children get general education?			
6	In what types of educational institutions can people get vocational education?			
7	In what types of educational institutions can people get higher education?			
8	What are specific features of the educational system in the country?			

### 5. Порядок выполнения работы

Прочитать и перевести текст, выделить и записать новые слова, ответить на вопросы по тексту, выполнить задание в группах, фронтальное обсуждение

### 6. Содержание отчета

Конспект

## Практическое занятие 5. Виртуальная школа

**1. Цель:** Развитие умений чтения с извлечением необходимой информации

**2. Задачи:**

- закрепление и систематизация теоретических знаний по лексической и грамматическим темам;
- совершенствование навыков чтения и перевода.

**3. Подготовка к работе:**

Повторение слов по теме “Образование”

**4. Задание:**

**Задание 1. Прочитайте текст на тему «Учитель он-лайн» и напишите, верны ли утверждения или нет:**

**THE ON-LINE TEACHER**



Mr. Frank Garret, 65, is a schoolteacher. He is English, but he lives in France, in the village of Yerville. Mr. Garret lives in France, but he works for an English school. He works on-line, and teaches from his home.

Every Monday he starts his job at 8.30 in the morning. He teaches French on-line from 9.00 in the morning to 3.30 in the afternoon, and then he finishes classes.

After on-line classes, Mr. Garret starts his daily routine as shopping, cleaning his flat, spending time with family. He arrives home at 9.30 in the evening, after a busy day.

Mr. Garret works off-line at English school only one day a week.

And what does he do on the other days? He teaches English on-line as well! He has a class of French students in Yerville, where he lives. He teaches his students from his home as well.

He says, "I love my job in England and I love my home in France. I'm a happy man."

1. Mr. Garret is 65 years old. – T/F
2. Mr. Garret is French. - T/F
3. Mr. Garret has a house in France. - T/F
4. Mr. Garret learns French in England. - T/F
5. Mr. Garret starts on-line classes at 9.30. – T/F
6. Mr. Garret works off-line in France one day a week. - T/F
7. Mr. Garret teaches French in Yerville. – T/F

**Задание 2. Опишите Ваш личный опыт дистанционного обучение, на английском языке. Сочинение должно быть на 2 страницы**

### **5. Порядок выполнения работы**

Прочитать и перевести текст, выделить и записать новые слова, ответить на вопросы по тексту, выполнить задание в группах, эссе

### **6. Содержание отчета**

Эссе

## **Практическое занятие 6, Написание мотивационного письма**

**1. Цель:** Совершенствование коммуникативных умений письма. Умение письменно передать информацию в виде эссе

## 2. Задачи:

- закрепление и систематизация теоретических знаний по лексической и грамматическим темам;
- обобщение знаний по составлению официальных писем;
- совершенствование навыков работы с текстом.

## 3. Подготовка к работе:

Повторение слов по теме “Колледж”

## 4. Задание:

**Задание 1. Оформите «шапку» для официального письма. Заполните отсутствующие элементы –**

From \_\_\_\_\_  
Name of applicant  
Address \_\_\_\_\_  
Contact Details  
Date \_\_\_\_\_  
To \_\_\_\_\_  
Name of Recipient  
Department/Designation,  
Name of Institution/Organization,  
Address, Contact Details  
Subject \_\_\_\_\_

**Задание 2. Прочитайте мотивационное письмо и ответьте на вопросы**

1. Which degree does the person hold?
2. Which subject is it?
3. How long has the online course lasted?

*Respected Sir/Madam,*

*Hope this letter finds you in prosperous health and good spirit.*

*I, (Name of the candidate) would firstly like to acknowledge the opportunity to depict my eagerness to study at your university through this letter. This university is unquestionably renowned, and I hold an immense passion for pursuing my master's from here. The university's rich culture and infrastructure always had me fascinated, and securing a chance to build my future here would be an honor.*

*I hold a bachelor's degree in Literature, and throughout those three years, I've associated with numerous stalwarts of the literature world and participated in workshops, training, and more. I've obtained the first class in my bachelor's degree and my in-depth knowledge about the subject will be quite worthwhile for your degree program. I've always desired to implement impressive advancements in the field of literature, and securing this master's program would be a great push toward improvement.*

*My internships with (names of the company) have also proved extremely beneficial in my learning curve. I've rigorously engaged in numerous projects that have built my knowledge as well as expertise in the working field as well. The hands-on experience in the industry has provided me with extensive outer knowledge as well. Furthermore, I've also pursued a 6-month online course on Women's Literature from (mention the organization name), and that has opened the doors to plentiful resources.*

*With this, I'd like to end my Letter of Motivation. I eagerly hope the university authority would grant me my coveted wish to pursue my master's degree at this eminent institute. My resume and educational qualifications speak of my interest in this subject, and securing a seat in this university will amp up my career in every way possible.*

*Warm Regards*

## **5. Порядок выполнения работы**

Прочитать и перевести текст, выделить и записать новые слова, ответить на вопросы по тексту, выполнить задание в группах, эссе

## **6. Содержание отчета**

Эссе

## Практическое занятие 7, Мое расписание

### **1. Цель:** Развитие навыков письма

### **2. Задачи:**

- закрепление и систематизация теоретических знаний по лексической и грамматическим темам;
- обобщение знаний социокультурной информации;
- совершенствование навыков чтения.

### **3. Подготовка к работе:**

Повторение слов по теме “Daily routine”

### **4. Задание:**

**Задание 1. Сделайте следующие предложения отрицательными и вопросительными:**

Пример,

(+) She usually gets up at 7 o'clock.

(-) She doesn't usually get up at 7 o'clock.

(?) Does she usually get up at 7 o'clock? или

(?) What time does she usually get up?

1) He goes to the supermarket every day.

(-) \_\_\_\_\_.

(?) \_\_\_\_\_.

2) They study at college well.

(-) \_\_\_\_\_.

(?) \_\_\_\_\_.

**Задание 2. Напишите слова в рамке с соответствующим предлогом времени:**

Пример: on Mother's Day

---

Saturday morning	weekends	my birthday	autumn
half past one	the twenty-first century		The afternoon
Thursday	November		Christmas Day

---

**Задание 3. Напишите собственные примеры предложений с предлогами - in at on**

**Задание 4. Прочитайте текст ниже. Составьте 10 вопросов к тексту.**

My name is Derek. I always wake up at 5 o'clock in the morning then I take a shower and put my clothes on. I have my breakfast and then I get the car out of the garage. I arrive to hisghchool at 7. At 11 o'clock I finish teaching classes, then I take my lunch break and talk with my friends. At around 12 noon I continue teaching classes until 4:20, then I drive home. When I get home, I usually watch some TV and chat with my family. At 9 o'clock I read a book and go to sleep.

**Задание 5. Напишите сочинение на тему – Мое раписание**

#### **5. Порядок выполнения работы**

Прочитать и перевести текст, выделить и записать новые слова, ответить на вопросы по тексту, выполнить задание в группах, написание эссе

#### **6. Содержание отчета**

Эссе

## Практическое занятие 8, Мой колледж

**1. Цель:** Развитие умений чтения с извлечением необходимой информации

#### **2. Задачи:**

- закрепление и систематизация теоретических знаний по лексической и грамматическим темам;
- совершенствование навыков письменно излагать сведения о колледже, навыки сравнений на английском языке.

#### **3. Подготовка к работе:**

Повторение слов по теме “Образование”

#### **4. Задание:**

**Задание 1. Прочитайте текст, подберите антонимы к таким словам, как -**

New, bright, comfortable, spacious, excellent, comfortable

College of Information Technology and Economics

I would like to tell you about my college. This is the College of Information Technology and Economics. First, I would like to note that our educational institution is not new, and has its own traditions. Our college was built more than seventy years ago, and among its graduates there are outstanding people who are well known in our scientific field. You can see their photos in the lobby, on the board of honor.

The classrooms at our college are bright, spacious and comfortable. They are all equipped with everything you need in our time: computers, video and interactive whiteboards. There are laboratories for the study of physics, chemistry and biology. Our college has six computer classes, where students use the Internet, create their first computer programs and projects in various subjects. There is also an excellent library that contains a variety of encyclopedias and dictionaries, books by classic and modern writers. Behind the library there is a large assembly hall for concerts and theatrical performances. There are several circles that students can attend after classes: a theater studio, a literary club, a dance studio.

**Задание 2. Сравните активности вашего колледжа и колледжа, описанного в тексте.**

**Заполните таблицу -**

College of Information Technology and Your College

Economics

**Задание 3. Образуйте степени сравнение и превосходной степени в словах из текста –**

New, bright, comfortable, spacious, excellent, comfortable

Заполните таблицу с прилагательными

Comparison degree

Superlative degree

**5. Порядок выполнения работы**

Прочитать и перевести текст, выделить и записать новые слова, ответить на вопросы по тексту, выполнить задание в группах, фронтальное обсуждение

**6. Содержание отчета**

### Практическое задание 9, Магазины

**1. Цель:** Развитие умений чтения с извлечением необходимой информации

**2. Задачи:**

- закрепление и систематизация теоретических знаний по лексической и грамматическим темам;
- совершенствование навыков чтения и перевода.

**3. Подготовка к работе:**

Повторение слов по теме “Образование”

**4. Задание:**

**5. Порядок выполнения работы**

Прочитать и перевести текст, выделить и записать новые слова, ответить на вопросы по тексту, выполнить задание в группах, фронтальное обсуждение

**6. Содержание отчета**

Конспект

### Практическое задание 10, Покупки

**1. Цель:** Развитие умений чтения с извлечением необходимой информации

**2. Задачи:**

- закрепление и систематизация теоретических знаний по лексической и грамматическим темам;
- обобщение знаний социокультурной и лингвострановедческой информации, правил речевого этикета;
- совершенствование умений составления диалога по теме.

**3. Подготовка к работе:**

Повторение слов по теме “Шоппинг”

**Задание 1. Прочитайте и переведите текст**

#### **Shops and Shopping Areas in Britain and in the USA**

The first place you go shopping in London could be one of the large stores. This is the kind of shop that sells all kinds of things such as furniture, food, toys, etc. Two famous London department stores are Selfridges's and Harrods's.

Covent Garden is another area of shops and restaurants built in and around the old fruit and vegetable market made famous in B. Shaw's Pygmalion and the musical My Fair Lady. Covent Garden is also used for the Royal Opera House in the same area.

Department stores, supermarkets, chemists and other kinds of shops are often called chain stores, which means they are part of a group of similar stores belonging to one company. Marks and Spencer is an example of a famous chain store. You can buy quality underwear and sweaters there. Other well-known chains sell shoes, clothing, household goods, etc. and many British High Streets have shops in national chains.

At some time you'll probably visit a supermarket too. As you might expect, you'll find not only food in supermarkets but also, for example, things for the house and alcoholic drinks. You'll also quite often find a shampoo, soap and common medicines. If you want something from the last group, however, it may sometimes be a better idea to visit a chemist's, especially if you are looking for medicine.

Shopping, however, is an art of its own and you have to learn slowly where to buy various things. In Britain as well as in America you can find different things at places you don't expect to. So if you are hungry, you can go to the chemist's (a drugstore in the USA). In large drugstores you may be able to get not only drugs, but stationary articles, candies, toys, braces, furniture. Every drugstore has a food counter with high stools in front of it and there they serve various juices, coffee, ice-cream, sandwiches and other dishes.

If you want cigarettes, go to the grocer's; if you want to have your shoes cleaned, go to the barber's; if you want a radio, go to a man's shop; if you want a suitcase, go to the chemist's. On the other hand, if you want to send telegrams they are handled by private companies. Nor has the post office anything to do with the telephone either, as the telephone service is supplied by the American Telephone and Telegraph Co.

You must be extremely careful concerning the names of certain articles. If you ask for suspenders in a man's shop, you receive a pair of braces; if you ask for a pair of pants, you receive a pair of trousers, and should you ask for a pair of braces, you receive a queer look.

You should also be careful about the prices! The sum may be more than appears on the price tags. This is because there's a sales tax in America on everything except basic foods.

### **Задание 2. Ответьте на вопросы по тексту**

1. What can you buy in a large store in London? 2. What famous London department stores do you know? 3. What is Covent Garden famous for? 4. What have you learnt about chain stores? 5. Why is it especially convenient to do shopping at supermarkets? 6. What can you buy at a chemist's? 7. How can word use be confusing when one goes shopping in Britain and in America? 8. How are telephone and telegraph services handled in the USA? 9. What can you say about a sales tax in America?

### **Задание 3. Прочитайте, переведите и разыграйте диалог по ролям**

SHOP ASSISTANT. What can I do for you?

WIFE. I'd like a summer dress. But something not too loud, please.

SHOP ASSISTANT. We have some very nice dresses in green and blue.

HUSBAND. Show us something in green, (to WIFE). Green is very becoming to you.

SHOP ASSISTANT. Here is a nice green dress. Such dresses are just coming in.

HUSBAND. It looks nice, doesn't it?

WIFE. Yes, indeed. I'd like to try it on.

SHOP ASSISTANT. Certainly. You can change in the cabin to the right.

WIFE. Isn't it lovely?

HUSBAND. Yes, you look smart in it. It's very becoming to you.

WIFE. Only I am afraid these stockings don't match. They are a bit too dark.

HUSBAND. Oh, that's all right. We'll just step over to the hosiery counter and buy the right shade, (to SHOP ASSISTANT). We shall take this dress.

SHOP ASSISTANT. Will you wear it now or shall I wrap it up for you?

WIFE. I'll wear it now. It's too much bother changing again.

HUSBAND. Thank you.

SHOP ASSISTANT. Come again.

WIFE. By all means.

**Задание 4. Напишите слово справа в нужном месте предложения. Переведите предложения**

1. I'd like glass of wine, please. **a**
2. Would you like cake? **some**
3. We don't have cheese. **any**
4. What would you like drink? **to**
5. Can I have stamps, please? **some**
6. 'James, you like cooking?' 'No, I don't.' **do**
7. Here are your apples. Do you want else? **anything**

**Задание 5. Распределите слова по колонкам (10 минут).**

Shopping bag, cash desk, fine quality, cheap, information desk, reasonable, kilo, worthy, pound, fitting room, shop-window, valuable, dozen, low, priceless, gram, half a kilo, counter, high, scales, worthless, cart, rise, expensive.

Shopping facilities	Prices	Quality	Measures
---------------------	--------	---------	----------

**Контрольные вопросы**



1. Do you like shopping for clothes? 2. What is the last thing you bought? 3. Where did you buy it? 4. What colour was it? 5. How much did it cost? 6. Did you buy anything to go with it?

### **5. Порядок выполнения работы**

Прочитать и перевести текст, выделить и записать новые слова, ответить на вопросы по тексту, выполнить задание в группах, фронтальное обсуждение

### **6. Содержание отчета**

Конспект

## Практическое задание 11, Посещение достопримечательностей.

**1. Цель:** Развитие умений чтения с извлечением необходимой информации

### **2. Задачи:**

- закрепление и систематизация теоретических знаний по лексической и грамматическим темам;
- обобщение знаний социокультурной и лингвострановедческой информации, правил речевого этикета;
- совершенствование умений составления диалога по теме.

### **3. Подготовка к работе:**

Повторение слов по теме “Путешествия”

Travelling

Exercise 1. Read the text about travelling as a hobby. Group the vocabulary along the following lines:

- Types of travelling
- The reasons why people travel
- Activities you can do while travelling
- Places of interest

For many people travelling is one of most favourite hobbies. They love visiting countries and cities, see historical sites and experience new cultures. They love museums and “tourist” traps. They like to incorporate their favourite hobby into a trip.

Those who love reading, travel to visit the homes and stomping grounds of their favorite authors, such as Hemingway’s house in the Florida Keys or the Edgar Allan Poe House and Museum in Baltimore. In Edinburgh, Scotland, they can take a literary pub tour that features dramatic readings and visits to taverns Sir Walter Scott and Robert Burns frequented.

If you like walking, there are a number of walking tours, whether of a neighborhood, a park, a waterfront area, or a historical district. Theme parks and zoos also often offer guided walking tours, many of which take you behind the scenes to see the inner picture of the place.

If you love painting, take a watercolor class in England’s Lake District or indulge in an artist’s retreat in Giverny, France (home of Monet). If you’re more into crafts, consider learning to make a traditional drum in Morocco or trying your hand at bamboo weaving in Borneo.

For many people, travelling is not just a hobby, it’s a lifestyle.

In a word, travelling expands and broadens our impression and knowledge about other continents, countries, modern cities and, of course, helps us to take a break from our hectic way of living and feel a different way of life.

**Exercise 2.** Read the text about the role of travelling for your future career. Complete the text using the words from the box.

to negotiate; potential employer; knowledge base; to strategize;  
an advantage; assertive

Travelling is not only fun. It can help you gain experience and improve skills that are of interest to employers. Travelling gives you communications skills, adaptability, negotiating skills, planning skills, leadership skills, decision-making skills, etc.

When you write your resume, you can create a separate section to discuss your international skills or give examples of your travelling experience during the interview to give yourself (1) ...

Travelling to foreign countries shows to your (2) ... that you have excellent communication skills, especially if you were able to pick up a new language.

Your employer understands that while travelling you have to adapt to unique situations which shows that you can adapt to the company culture as well as new policies, procedures, and technologies.

During your trip you learn (3) ... for a better taxi fare or a product in open-air shops. This skill can also make you a more appealing candidate.

Travellers need to do a lot of planning from what to pack to what cities and sites to visit to what modes of transportation to use. Your future-boss will appreciate the fact that you have the ability (4) ... and manage your time.

As a traveller you must be good at problem solving. You need to be creative when you miss a train connection or lose your baggage or try to get cough drops. Of course, you can use your problem-solving skill in the workplace.

Travelling gives you confidence and makes you more (5) ... in your decisions, which is also a highly valuable leadership skill.

Travel often shows a desire to learn, and you can bring up the fact that you are passionate about broadening your (6) ... .

## **5. Порядок выполнения работы**

Прочитать и перевести текст, выделить и записать новые слова, ответить на вопросы по тексту, выполнить задание в группах, фронтальное обсуждение

## **6. Содержание отчета**

Конспект

## Практическое занятие 12, Хобби

**1. Цель:** Развитие умений чтения с извлечением необходимой информации

**2. Задачи:**

- закрепление и систематизация теоретических знаний по лексической и грамматическим темам;
- обобщение знаний социокультурной информации.

### 3. Подготовка к работе:

Повторение слов по теме “Хобби”

#### Задание 1. Найдите в каждой строке лишнее слово:

1. music, dancing, painting, games;
2. games, sports, physical activity, autographs;
3. knitting, buttons, dolls, books;
4. ceramics, metalworking, jewelry making, singing;
5. unique, usual, rare, unusual.

#### Задание 2. Раскройте скобки, употребляя глаголы в Present Continuous:

Пример: Nick ... (go) to school. – Nick **is going** to school.

6. Phillip ... (play) volleyball now.
7. She ... (not watch) TV, she ... (read) a book.
8. Look! They ... (dance) over there.
9. Stop talking, please! I ... (work).
10. You can turn off the radio, I ... (not listen) to it.

#### Задание 3. Заполните фразы в диалоге:

A: What ... you ... 11) (do)?

B: I ... 12) (listen) to music.

A: What ... you ... 13) (listen)?

B: It ... 14) (be) jazz.

A: Are you fond of jazz?

B: Yes, I ... 15) (enjoy) jazz and blues.

#### Задание 4. Раскройте скобки, употребляя глаголы в скобках во временах Present Simple или Present Continuous:

16. I usually ... (go) shopping at weekends.
17. We ... (go) to the shop at the moment.
18. Mike often ... (play) football on Sundays.

19. Listen! Mike ... (play) the guitar.

20. Mary ... (enjoy) swimming.

Speak about you hobby or free time activity

## Вариант 2

1. Заполните пропуски словами, данными ниже. Напишите в тетради цифру и вариант ответа - букву.

Пример: 1) - d

A: Hi, Fiona. 1) \_\_\_ the party?

B: Yes, 2) \_\_\_, thanks, but can I ask you a question?

A: Of course.

B: 3) \_\_\_ that man over there? I think he's very good looking.

A: Who? I can't see.

B: He 4) \_\_\_ near the door.

A: 5) \_\_\_ jeans and a red T-shirt?

B: No, 6) \_\_\_. He's got brown hair and he's tall and very handsome.

A: Oh, that's Robert.

B: What 7) \_\_\_?

A: He's a writer. He 8) \_\_\_ a novel at the moment.

B: I'd love to meet him. Is he married?

A: No, but he 9) \_\_\_ married next month.

B: Oh well, I 10) \_\_\_ for a new boyfriend at the moment anyway!

1. a Enjoy b You enjoy c Do you enjoy d Are you enjoying
2. a I am b I enjoy c I'm d I do
3. a Where b Who's c Who are d Whose
4. a are standing b standing c 's standing d stands
5. a He's wearing b Is he wearing c He is wearing d Does he wear
6. a he isn't b I'm not c he doesn't d he is
7. a is he doing b his job c did he do d does he do
8. a writes b are writing c 's writing d writing

9. a gets b got c 's getting d getting
10. a not look b 'm not looking c isn't looking d don't look
2. Составьте предложения из следующих слов:
11. young, prefer, Some, people, sport, extreme;
12. because, reading, people, Many, collect, enjoy, books, they;
13. are, kinds, hobbies, different, of, There;
14. friend, taking, My, is, pictures, now;
15. basketball, often, play, They. volleyball, and.
3. Поставьте глаголы в скобках в Present Simple или Present Continuous. В тетрадях напишите номер предложения и ваш вариант ответа.

Пример: 16) - take,

16. We usually (take) the bus to town, but today we (go) by car.
17. A: Where ... you usually (go) on Friday evenings?  
B: To a disco.
18. A: It's 11.30. Why ... you (work) so late?  
B: Because I (have) a lot of homework.
19. A: Where ... your parents (live)?  
B: In a small village near Oxford.
20. A: ... they (like) living the country?  
B: Yes, they do.
21. A: What ... you usually (have) for breakfast?  
B: Toast. But today I (have) some fruit because there isn't any bread.
22. A: The telephone (ring). Can you answer it?  
B: OK.

4. Speak about your hobby or free time activity.

### 5. Порядок выполнения работы

Прочитать и перевести текст, выделить и записать новые слова, ответить на вопросы по тексту, выполнить задание в группах, фронтальное обсуждение

### 6. Содержание отчета

Конспект

## Практическое занятие 13, Необычные хобби в разных странах

**1. Цель:** Развитие умений чтения с извлечением необходимой информации

**2. Задачи:**

- закрепление и систематизация теоретических знаний по лексической и грамматическим темам;
- совершенствование навыков чтения и перевода;
- обобщение межкультурных знаний.

**3. Подготовка к работе:**

Повторение слов по теме “Хобби”

**Задание 1. Прочитайте текст про хобби британцев и американцев. Передавайте глаголы из активного залога в пассивный, заполнив таблицу.**

### Hobbies in Great Britain and USA

Hobbies are a big British and American tradition. A hobby is a special interest or activity that you do in your time off.

A «hobby» is usually something that a person does alone. But American (and British) families sometimes like to do things together too. Some American families have quite a lot of money to spend on their recreation. They can all enjoy their holiday home or their boat somewhere in the country away from it. Americans love to get out of town into the wild and many go for holidays or long weekends into the thirty-five fabulous national parks.

Some people have animals as hobbies. They keep rabbits or go fishing. They train dogs to do tricks or keep pigeons to race and carry messages. Some are crazy about plants.

Others are mad about their car or their motorbike. They spend their Saturdays and Sundays washing them and painting them. But Americans do not only spend their free time having fun.

Children and teenagers are great collectors. Millions take part-time courses in writing, painting and music and at the weekends the museums, art galleries and concert halls are full. Everyone in these countries is very interested in culture.

Active voice

Passive voice

**Задание 2. Ответьте на вопросы**

1. What is Hobby?
2. Why is boating one of favorite hobbies in USA?
3. Do animals take part in hobbies?

**Задание 3. Придумайте предложения со словами из таблицы.**

**К каким культурам эти хобби подходят больше всего?**

Sailing – мореплавание

Camping – отдыхать в лагере

Climbing – альпинизм, лазить по горам

Diving – подводное плавание, ныряние

Surfing – сёрфинг, плавать на доске

Horseracing – скачки на лошадях

rollerskates – кататься на роликах

Sailing – мореплавание

Camping – отдыхать в лагере

Climbing – альпинизм, лазить по горам

Diving – подводное плавание, ныряние

Surfing – сёрфинг, плавать на доске

Horseracing – скачки на лошадях

rollerskates – кататься на роликах

Sailing – мореплавание

Camping – отдыхать в лагере

Climbing – альпинизм, лазить по горам

Diving – подводное плавание

Surfing – сёрфинг, плавать на доске

Horseracing – скачки на лошадях

rollerskates – кататься на роликах

**Задание 4. Придумайте определения к словам в кроссворде.**

**Across – по горизонтали**

**Down – по вертикали**

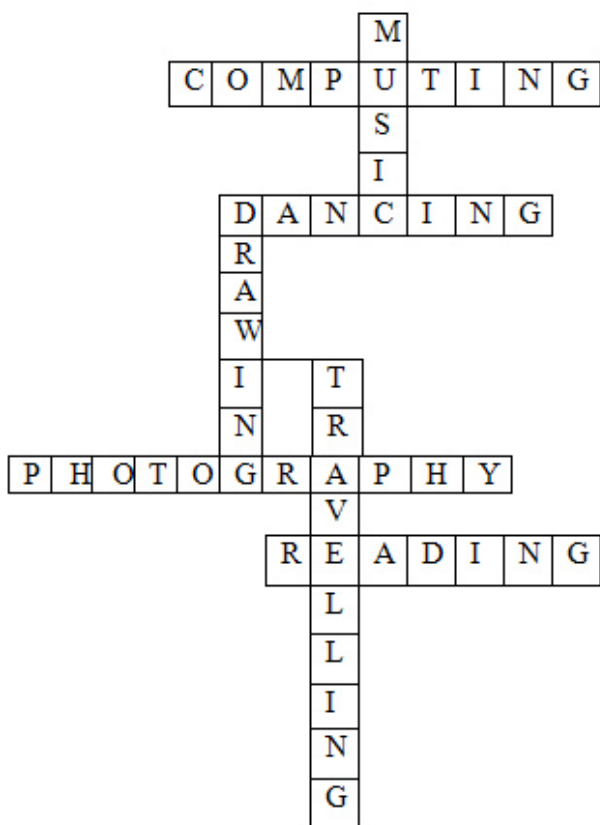

### 5. Порядок выполнения работы

Прочитать и перевести текст, выделить и записать новые слова, ответить на вопросы по тексту, выполнить задание в группах, фронтальное обсуждение

### 6. Содержание отчета

Конспект

## Практическое занятие №14, Чтение. Литературные жанры

1. **Цель:** Развитие умений чтения с извлечением необходимой информации

2. **Задачи:**

- закрепление и систематизация теоретических знаний по лексической и грамматическим темам;
- совершенствование навыков чтения и перевода.

3. **Подготовка к работе:**

Повторение слов по теме “Книги”

**Задание 1. Прочитайте текст и выполните упражнение**

### Famous Russian Authors

Russia has produced some of the greatest people in the area of literature. The Golden age of Russian poetry began with **Alexander Pushkin** who is the founder of Russian literary language and is more commonly known as the ‘Russian Shakespeare’. After the Golden age various



genres became popular in Russia, starting from poetry, novels, and short fiction stories to literary realism and symbolism.

**Alexander Solzhenitsyn** He was a Russian novelist, writer and dramatist. He used his work to spread *awareness* about the Gulag, the Soviet Union government agency that administered labor camps. His most famous contributions include 'The Gulag archipelago' and 'One day in the life of Ivan Denisovich'.

**Ivan Turgenev** He was a novelist and short story writer who was initially rejected by many publishers on his work 'Father and Sons' which is now considered a classic.

**Vladimir Nabokov** He was a Russian-American novelist and entomologist. His first nine novels were in Russian after which he became more prominent and started writing English novels which are very popular worldwide. His much appreciated, controversial novel 'Lolita' was written in Russian and English and attained the status of a classic. He was also a finalist for the national book award for fiction seven times.

**Bulgakov** was a writer, physician and playwright active during the early twentieth century. He was claimed as the most controversial writers of his time and was famous for his satires on the society in Soviet Union. Although he received his education in medicine. His most significant work is his novel 'The master and margarita'.

**Anton Chekhov** He is acknowledged as the greatest short fiction writer in history. He was initially a physician but after gaining interest in literature and started writing seriously. Therefore he proceeded with his career in medicine as well as writing books alongside. His most influential work was 'The Seagull' and 'Uncle Vanya'.

**Bunin** was the first Russian author who was awarded with the Nobel Prize in literature. He was noted for artistry, realism, poetry and classical traditions. The young writer spent his childhood in some financial crisis due to the head of the family being a gambling addict and therefore could not receive the best of the education.

## Задание 2. Определите, верны ли утверждения - True/False

- 1 Alexander Solzhenitsyn worked to spread *awareness* about the II World War in the Soviet Union,
- 2 Vladimir Nabokov wrote in English and in Russian languages,
- 3 Anton Chekhov has gained his career in medicine as well as writing,
- 4 Ivan Turgenev was not published for a long time,
- 5 Alexander Pushkin is known by Shakespeare,
- 6 Bunin was the only Russian author who won the Nobel Prize in literature,
- 7 Bulgakov received his education in medicine and wrote satires on the society in Soviet Union.

## Задание 3. Аудирование

Пройдите по ссылке послушайте видео несколько раз

<https://youtu.be/xAVAGrWhZaQ> переведите фразы данные внизу и

пришлите голосовое сообщение с прочтением этих фраз. Послушайте и произнесите несколько раз

- 1 Moral and philosophical depth and intensity
- 2 To identify yourself as a member of society-
- 3 Their moral example
- 4 The course of the world literature
- 5 Facing political pressure
- 6 Unknown to most writers
- 7 How did that happen?

**4. Ответьте на вопросы** Главное правильно построенное предложение.

Избегайте сложных конструкций. Точный ответ есть только на первый вопрос.

- 1 When was Russian National literature established?
- 2 What did Russian writers write about?
- 3 Who were the writers
- 4 What makes them so great?

**5. Порядок выполнения работы**

Прочитать и перевести текст, выделить и записать новые слова, ответить на вопросы по тексту, выполнить задание в группах, фронтальное обсуждение

**6. Содержание отчета**

Конспект

## Практическое занятие №15, Кино. Жанры кино

**1. Цель:** Развитие умений чтения с извлечением необходимой информации

**2. Задачи:**

- закрепление и систематизация теоретических знаний по лексической и грамматическим темам;
- совершенствование навыков чтения и перевода.

**3. Подготовка к работе:**

Повторение слов по теме “Кино”

**4. Задание:**

**Задание 1. Прочитайте текст**

### **Cinema: How It All Began**

The modern theatre developed from the Ancient Greek one, so it has several millennia of history.

Cinema is much younger than theatre. It was born at the end of the 19th century. The first people who showed the first films to a paying public were the Lumière ['lu:mieə] Brothers of France. They did this at the Grand Café, Boulevard des Capucines ['bu:ləvɑ:də,kəpu'tʃini], Paris, on the

20th February 1896. This was the first cinema show and it was quickly followed by many others in all parts of the world. The first films showed moving people and transport or newsreels [ˈnju:zri:lz] of processions and wars, and short comedies. In 1901 France was the first country to produce a dramatic film, *The Story of a Crime*, which was followed by *The Great Train Robbery* in the United States in 1903.

At first, films were shown anywhere: in music halls, clubs and shops. By 1908, special film theatres were being built to give regular programmes. At this time cinema rapidly developed in both the New and the Old World. Charlie Chaplin made his first film, *Making a Living*, in 1914 in the USA.

The Russian film industry was now going its own way. It produced such great films as Protazanov's *The Queen of Spades* (1916) and *Father Sergius* [ˈsə:dʒiəs] (1918). Both films starred Ivan Mosjoukhin, the famous actor. A little later Russia's great achievement in cinema was connected with its directors such as Eisenstein [ˈaizinstain] (*The Battleship "Potemkin"*), Pudovkin (*Mother*), Kuleshov (*By the Law*), Dovzhenko (*Earth*), and others.

Then, in 1927, Warner Brothers in Hollywood made the first film in which an actor sang and spoke. The film was called *Jazz Singer*. It opened a new era in films – the era of the "talkies". The film mostly told its story with titles, but it had three songs and a short dialogue. There were long lines of people in front of the Warner Theatre in New York. The silent film was dead within a year. The first one hundred percent sound film, *Lights of New York*, appeared in 1928. The first colour film were made in the 1930s, but the black-and-white films are made even today.

## **Задание 2. Ответьте на вопросы**

1. When cinema was born?
2. What country produced the first dramatic film?
3. Why is the film *Jazz Singer* important in the history of cinema?
4. How many names of films, actors and directors mentioned in the text can you remember?

## **Задание 3. Найдите в тексте названия фильмов**

- |                          |                              |
|--------------------------|------------------------------|
| 1. Зарабатывая на жизнь  | 6. Большое ограбление поезда |
| 2. История преступления  | 7. Отец Сергей               |
| 3. Пиковая дама          | 8. По закону                 |
| 4. Огни Нью-Йорка        | 9. Земля                     |
| 5. Броненосец «Потемкин» | 10. Мать                     |

## **Задание 4. Соотнесите обе колонки – названия жанров фильмов с их описанием**

1 a musical	A a film about space travel or life in an imaginary future
2 a western	B a film about criminals and detectives
3 a comedy	C a film with lots of music and dance
4 a science fiction film	D a film about cowboys and life in the Wild West
5 a crime film	E a funny film with a happy ending
6 a horror film	F a film in which mysterious and frightening things happen

#### Задание 4. Отгадайте названия кинопрофессий

1. You tell the actors what to do: you are	3. Your sister created the story and wrote the actors' words. She is:
a) Director	a) A scriptwriter
b) Producer	b) An editor
c) Cameraman	c) A playwright
2. Your uncle is financing the film. What is he called?	4. The person who puts all the different pieces of the film together is called:
a) The director	a) A cameraman
b) The producer	b) An editor
c) The bank manager	c) A scriptwriter

#### 5. Порядок выполнения работы

Прочитать и перевести текст, выделить и записать новые слова, ответить на вопросы по тексту, выполнить задание в группах, фронтальное обсуждение

#### 6. Содержание отчета

Конспект

## Практическое занятие №16. Обобщение лексического и грамматического материала.

**1. Цель:** Обобщение лексического и грамматического материала.

**2. Задачи:**

- закрепление и систематизация теоретических знаний по лексической и грамматическим темам;
- совершенствование навыков чтения и перевода.

**3. Подготовка к работе:**

Повторение пройденного лексического и грамматического материала

**4. Задание:**

**5. Порядок выполнения работы**

Прочитать и перевести текст, выделить и записать новые слова, ответить на вопросы по тексту, выполнить задание в группах, фронтальное обсуждение

**6. Содержание отчета**

Конспект

4 семестр

## Практическое занятие 1. Здоровое питание.

**Цель работы:** закрепление и систематизация теоретических знаний по лексической и грамматическим темам;  
обобщение знаний социокультурной и лингвострановедческой информации;  
совершенствование навыков чтения текста на английском языке.

**Задачи работы:**

*Образовательные:*

Углубление и расширение знаний обучающихся по теме «Здоровое и нездоровое питание», применение и изменение полученных знаний в практической деятельности  
Умение воспринимать на слух и понимать краткие сообщения

*Развивающие:*

Развитие языковых, познавательных способностей обучающихся, готовности к общению во всех сферах бытия.

Развитие познавательного интереса у обучающихся, умения обобщать, анализировать полученную информацию, сравнивать.

Развитие памяти, речи, логического мышления.

Выполнение заданий творческого характера, требующих от обучающихся системного, исследовательского, нетрадиционного подхода к их решению.

*Воспитательные:*

Формирование ценностного отношения обучающихся к здоровью и здоровому образу питания.

Формирование потребности употреблять здоровую пищу.

**Подготовка к работе**

### **№ 1. Answer the questions:**

- 1) What kind of food do you like?
- 2) What kind of food do you dislike?
- 3) Do you have a favourite dish?
- 4) What is your favourite dish?
- 5) What is your favourite drink? Can you cook?
- 6) What can you cook?
- 7) What food do you usually buy when you go to the shops?
- 8) Do you often go to supermarkets?

### **№2. Read the text.**

#### **10 Tips To Healthy Eating**

Experts agree the key to healthy eating is the time-tested advice of balance, variety and moderation. In short, that means eating a wide variety of foods without getting too many calories or too much of any one nutrient. These 10 tips can help you follow that advice while still enjoying the foods you eat.

1. *Eat a variety of nutrient-rich foods.* You need more than 40 different nutrients for good health, and no single food supplies them all. Your daily food selection should include bread and other whole-grain products; fruits; vegetables; dairy products; and meat, poultry, fish and other protein foods. How much you should eat depends on your calorie needs. Use the Food Guide Pyramid as a handy reference.
2. *Enjoy plenty of whole grains, fruits and vegetables.* Surveys show many people don't eat enough of these foods. Do you eat 6-11 servings from the bread, rice, cereal and pasta group, 3 of which should be whole grains? Do you eat 2-4 servings of fruit and 3-5 servings of vegetables? If you don't enjoy some of these at first, give them another chance. Look through cookbooks for tasty ways to prepare unfamiliar foods.
3. *Maintain a healthy weight.* The weight that's right for you depends on many factors including your sex, height, age and heredity. Excess body fat increases your chances for high blood pressure, heart disease, stroke, diabetes, some types of cancer and other illnesses. But being too thin can increase your risk for osteoporosis, menstrual irregularities and other health problems. If you're constantly losing and regaining weight, a registered dietitian can help you develop sensible eating habits for successful weight management. Regular exercise is also important to maintaining a healthy weight.
4. *Eat moderate portions.* If you keep portion sizes reasonable, it's easier to eat the foods you want and stay healthy. Did you know the recommended serving of cooked meat is 3 ounces, similar in size to a deck of playing cards? A medium piece of fruit is 1 serving and a cup of pasta equals 2 servings. A pint of ice cream contains 4 servings. Refer to the Food Guide Pyramid for information on recommended serving sizes.
5. *Eat regular meals.* Skipping meals can lead to out-of-control hunger, often resulting in overeating. When you're very hungry, it's also tempting to forget about good nutrition. Snacking between meals can help curb hunger, but don't eat so much that your snack becomes an entire meal.
6. *Reduce, don't eliminate certain foods.* Most people eat for pleasure as well as nutrition. If your favorite foods are high in fat, salt or sugar, the key is moderating how much of these foods you eat and how often you eat them.  
Identify major sources of these ingredients in your diet and make changes, if necessary. Adults who eat high-fat meats or whole-milk dairy products at every meal are probably eating too much fat. Use the Nutrition Facts panel on the food label to help balance your choices.  
Choosing skim or low-fat dairy products and lean cuts of meat such as flank steak and beef round can reduce fat intake significantly.

- If you love fried chicken, however, you don't have to give it up. Just eat it less often. When dining out, share it with a friend, ask for a take-home bag or a smaller portion.
7. *Balance your food choices over time.* Not every food has to be "perfect." When eating a food high in fat, salt or sugar, select other foods that are low in these ingredients. If you miss out on any food group one day, make up for it the next. Your food choices over several days should fit together into a healthy pattern.
  8. *Know your diet pitfalls.* To improve your eating habits, you first have to know what's wrong with them. Write down everything you eat for three days. Then check your list according to the rest of these tips. Do you add a lot of butter, creamy sauces or salad dressings? Rather than eliminating these foods, just cut back your portions. Are you getting enough fruits and vegetables? If not, you may be missing out on vital nutrients.
  9. *Make changes gradually.* Just as there are no "superfoods" or easy answers to a healthy diet, don't expect to totally revamp your eating habits overnight. Changing too much, too fast can get in the way of success. Begin to remedy excesses or deficiencies with modest changes that can add up to positive, lifelong eating habits. For instance, if you don't like the taste of skim milk, try low-fat. Eventually you may find you like skim, too.
  10. *Remember, foods are not good or bad.* Select foods based on your total eating patterns, not whether any individual food is "good" or "bad." Don't feel guilty if you love foods such as apple pie, potato chips, candy bars or ice cream. Eat them in moderation, and choose other foods to provide the balance and variety that are vital to good health.

## THE FOOD GUIDE PYRAMID

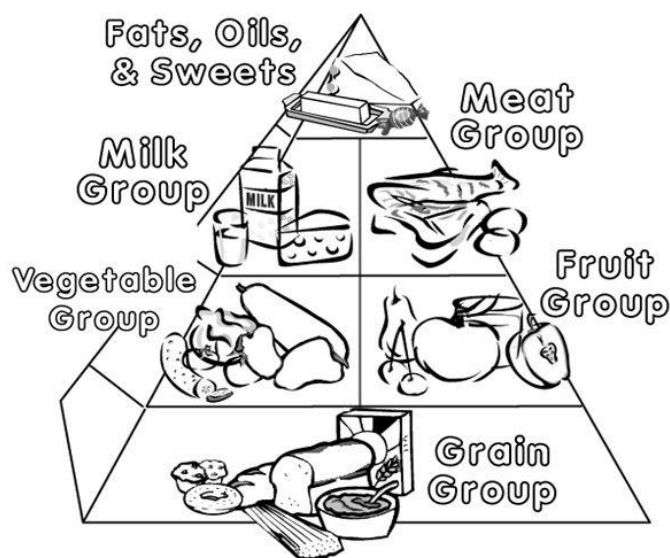

### The Food Guide Pyramid

The Food Guide Pyramid is a practical tool to help you make food choices. Using the Pyramid enables you to eat a variety of foods daily so that you can get the nutrients you need.

To make the most of the Pyramid, you need to know what counts as a serving.

Food Group - Serving Size

- Bread - 1 slice bread, 1/2 bagel or English muffin, 1 ounce ready-to-eat cereal, 1/2 cup cooked cereal, rice or pasta, or 5-6 small crackers
- Vegetable - 1 cup raw, leafy vegetables, 1/2 cup cooked or chopped raw vegetables or 3/4 cup vegetable juice
- Fruit - 1 medium piece of fruit, 1/2 cup mixed fruit or 3/4 cup fruit juice
- Milk - 1 cup milk or yogurt, 1 1/2 ounces natural cheese or 2 ounces process cheese
- Meat - 2 - 3 ounces cooked lean meat, poultry or fish (about the size of a deck of cards)
- Other foods which count as 1 ounce meat: 1/2 cup cooked dry beans, 1 egg, 2 tablespoons peanut butter or 1/3 cup nuts

## Практическое занятие 2. Посещение ресторана.

**Цель работы:** закрепление и систематизация теоретических знаний по лексической и грамматическим темам;  
обобщение знаний социокультурной и лингвострановедческой информации;  
совершенствование навыков чтения текста на английском языке.

**Задачи работы:**

*Образовательные:*

Углубление и расширение знаний обучающихся по теме «Здоровье и спорт», применение и изменение полученных знаний в практической деятельности

Умение воспринимать на слух и понимать краткие сообщения

*Развивающие:*

Развитие языковых, познавательных способностей обучающихся, готовности к общению во всех сферах бытия.

Развитие познавательного интереса у обучающихся, умения обобщать, анализировать полученную информацию, сравнивать.

Развитие памяти, речи, логического мышления.

Выполнение заданий творческого характера, требующих от обучающихся системного, исследовательского, нетрадиционного подхода к их решению.

*Воспитательные:*

Формирование ценностного отношения обучающихся к здоровью и здоровому образу питания.

Формирование потребности употреблять здоровую пищу.

### **№ 1. Translate the abstract from English into Russian.**

#### *At the restaurant*

Some years ago it was rather difficult to find a place for eating in Moscow. There were few canteens, cafes and restaurants where people could have lunch, dinner or a snack. But Moscow has changed. Nowadays there are a lot of different places here where we can eat decent food at a reasonable price and take someone for lunch on business. If you want to eat on the run, you should go to a fast-food restaurant: McDonalds, “Russian Bistro” or Pizza Hut. If you are in a hurry, you can have a snack in a bar. But if you seek the gastronomical experience of your life, you should go somewhere else. There are hundreds of restaurants in Moscow to satisfy



everyone's taste. In European, American and oriental restaurants of Moscow you can order international dishes although each restaurant as a rule specializes in one of the national cuisines. It is impossible to describe all the variety of delicious dishes of different countries. Our advice is to visit these restaurants and taste everything yourself.

I spend a lot of time at the college that is why it's necessary to have a snack time there. During the break I go to have lunch to our college canteen. It's always full of people at this time. I go to the service counter and line up. There is self-service at our canteen. Sometimes it takes quite a lot of time to stand in the line and I have to gulp my lunch in five minutes. The choice of dishes in our canteen is rather rich, the quality of food is good and the prices are reasonable. You can take the first dish, the main course and the dessert. Then you go to the counter, pay for everything you've chosen and take your seat and enjoy your meal. Besides the kitchen staff and the cashier two or three students on duty help to clear the plates and cups off the tables and to keep order in the canteen.

**№2. Make a dialogue, using the following words and word combinations.**

To eat decent food at reasonable price – прилично поесть по разумной цене

To take someone for lunch on business – пригласить кого-либо на бизнес ланч

To eat on the run – поесть на бегу

To experience the dishes – попробовать блюда

To be in a hurry – спешить

To have a snack – перекусить

To take a quite bite – перекусить

To satisfy one's taste – удовлетворить чей-либо вкус

To keep the old traditions – хранить старые традиции

**№3. Translate the sentences, using your active vocabulary.**

1. Я знаю хороший ресторан недалеко от нашего офиса, куда ты можешь пригласить своего гостя на бизнес-ланч.
2. В этом кафе вы можете прилично поесть по разумной цене.
3. У меня никогда нет времени на обед, я всегда ем на бегу.
4. Если вы спешите, то можете пообедать в ресторане быстрого питания.
5. Если вы хотите пополнить свой гастрономический опыт, то должны пообедать в ресторане быстрой кухни.
6. В Москве сейчас много ресторанов, которые хранят традиции русской кухни.
7. В каждом ресторане есть свое фирменное блюдо.
8. В Москве есть также много ресторанов, которые специализируются на какой-либо национальной кухне.
9. Народы Индокитая используют вместо соли соевый соус.
10. Невозможно описать все многообразие национальных блюд разных стран.

**№4. Ordering food and drink**

Ready, order, you, are, to?

Soup, can, Yes, some, have, chicken, please, I.

Else, anything?

Sandwich, a, like, Yes, cheese, would, I.

Drink, you, would, to, like, anything?

Please, mineral, a, water.

Составьте и подготовьте в парах диалог по теме "In a restaurant".

**№ 5. Write a composition on subjects (by your choice) :**

“McDonalds. I’m lovin it”,

“Coca-Cola. Enjoy Coca-Cola”,

“Famous Russian Restaurants”

“Famous European and American Restaurants. It’s worth to visit”

“Chinese and Indochinese restaurants. The most exotic dishes”

“Japanese restaurants. The atmosphere of East”

“The restaurant of my dream”

**Using the vocabulary of the lesson, create (paint, write, decorate) your own menu card for the restaurant. Don’t forget about the list of beverages and ales.**

Практическое занятие 3. Готовим дома: рецепт любимого блюда.

**№1. Answer the questions**

1. What do you eat for breakfast on a weekday/at the weekend?
2. Do you always eat the same thing?
3. Who prepares it?
4. How much time do you have for breakfast?
5. Do you like the traditional breakfast in your country?
6. Is your breakfast light or substantial? What does it usually consist of?
7. Can you cook well? What dishes can you cook? What is your favourite dish? Is it easy to cook?
8. What did your friend treat you to when you came to visit her?
9. Who does the cooking in your family?
10. Do you like your food spicy?
11. Are you a hearty or a poor eater?
12. What did you have for dinner yesterday?
13. Where do you have your dinner?
14. What does it usually consist of?
15. How many meals do you have daily?

**№2. Complete the sentences:**

We eat meat with ...

We eat fish with ...

We eat soup with ...

We put salad on ...

We drink milk from ...

We drink tea from...

We boil the water in...

**№3. Write what you do with them: a frying pan - I fry potatoes in the frying pan.**

- a frying pan
- a sauce-pan

- a bowl
- a chopping board
- a spoon
- a knife
- an oven

**Read, translate and act out the following dialogues.**

**Dialogue 1**

**Misha:** I'm hungry. Let's have a snack!

**Robin:** But Betsey isn't in.

**Alice:** Is there any food in the fridge? Let's see. We have some milk, some butter, some ham, some cheese, some fish, some tomatoes and some bananas.

**Robin:** Can we make an omelette?

**Alice:** No we can't because we don't have any eggs.

**Misha:** Can we make ham and cheese sandwiches?

**Alice:** No we can't because we don't have any bread.

**Misha:** Can we make fish and chips? **Alice:** No, we can't because we don't have any potatoes.

**Betsey:** Hi, guys! Are you hungry? Let's go shopping!

**Dialogue 2**

**A:** Hello!

**B:** Hi, I haven't seen you for ages! How's life?

**A:** I'm fine. Thank you, and you?

**B:** I'm OK. You know, I've watched an interesting TV programme today. It was really exciting.

**A:** What about?

**B:** Cooking. They gave some recipes and explained how to make different dishes step by step. The programme is useful for my future profession. You know, I'm going to be a cook.

**A:** Oh! I'm keen on cooking too. I think you can make a lot of wonderful things already. By the way, what is your favourite Russian dish?

**B:** I like Macaroni, Naval Style.

**A:** Can you cook it yourself?

**B:** Of course, it's rather simple.

**A:** What do you need to make this dish?

**B:** Well, take 9 oz (250gm) macaroni, 1 lb (500gm) boneless meat, 2 onions, 4 oz (100gm) butter; salt and pepper to taste.

**A:** And how do you cook it?

**B:** First, you should boil the macaroni in salted boiling water until done and then transfer into a colander. Put the meat through a meat-grinder, salt, and brown, stirring, until done. Separately brown the minced onions. After that, mix the meat and onions and again put through the meat-grinder; mix it with macaroni on a frying-pan and heat well.

**A:** Oh! It's not difficult at all. I'll try to make the dish today. Thank you for the recipe.

**B:** Not at all. I wish you Good Luck in your cooking! Bye for now!

**A:** Good-bye! See you later!

## Практическое занятие 4. Болезни и их лечение

### Illnesses

1. adiposity - ожирение
2. angina - ангина
3. antritis - гайморит

4. appendicitis - аппендицит
5. asthma – астма
6. backache – боль в спине
7. bronchitis - бронхит
8. cancer - рак
9. cholera - холера
10. cough - кашель
11. cold - простуда, насморк
12. diabetes - диабет
13. diarrhoea - понос
14. disease - болезнь
15. the flu - грипп
16. headache – головная боль
17. illness - болезнь
18. inflammation - воспаление
19. insomnia - бессонница
20. measles - корь
21. mumps - свинка
22. plague - чума
23. scab - чесотка
24. smallpox - оспа
25. snar - запор
26. stomachache – боль в животе
27. toothache – зубная боль
28. stuffer(ing) - заикание
29. ulcer - язва
30. upset stomach - расстройство желудка

№1 .Read and translate the text:

Everybody must know how to give the first aid. The first aid saves many lives. The most important thing in an emergency is not to lose one's head. The first aid is the help which you give to an injured person. You must know different methods of helping in accidents. When you give the first aid you must be calm and act without panic.

№.2 Say in English: Первая помощь, оказывать первую помощь, главное в чрезвычайной ситуации, не потерять голову, пострадавший человек, разные методы, помощь при несчастном случае, должен быть спокойным, действовать без паники.

№.3 Answer the questions: 1. What is the first aid? 2. What is the most important thing in an emergency? 3. How must a person act when he gives the first aid?

Read the text and try to understand it:

I'm Jett Oliver. I'm 24 years old. I decided to become a doctor when I saw two of them giving the first aid to a driver at the place of an accident when I was a boy. I started as a driver in ambulance, and studied for five years to become a qualified doctor. Now I manage life-saving procedures myself. It's part of my everyday work to defibrillate the heart of a cardiac arrest, to apply splints to limbs and dress wounds, and to set dropping bottles. I have to make quick decisions – it's an important part of giving emergency treatment. It is also necessary to communicate clearly and not to lose my head in some difficult situations. And situations are often very difficult, especially when we have to deal with people under the influence of drugs and alcohol. Doctors are always 7 first at the place when there is a suicide, a road accident, or a fire. When you save a life, you must act without panic. It's the best job in the world.

№ 4. Answer the questions:

1. When did Jett decide to become a doctor? 2. How long did he study for the job? 3. What is the part of his everyday work? 4. Is it important for Jeff to make quick decisions? 5. Does he like his job? Why? 6. Do you like Jeff's work?

№ 5 Make up the word combinations and find the sentences with them in the text:

1. become a a life 2. deal with b as a driver 3. dress c a qualified doctor 4. make d wounds 5. save e people 6. start f decisions

Read the text:

Accidents at home In the UK, about 2.8 million people every year seek treatment at an Accident and Emergency department after an accident at home. More than 3,000 people die every year as a result of home accidents.

Research shows that most home accidents occur in the following categories: • Falls • Poisoning • Fires • DIY accidents (Damage It Yourself) • Kitchen accidents • Choking • Burns • Garden accidents • Drowning Many of these accidents could be prevented by following simple guidelines. With this in mind, the government produces a range of safety advices leaflets to warn people about dangers around the home. This would clearly reduce the load on Accident and Emergency departments and emergency services, such as police, fire and ambulance, allowing them to use their limited resources for other work.

№ 6. Which of categories mentioned in the text refer to the home accidents?

1. Lucy Mann left a candle burning when she went to bed.
2. Two-year-old Toby Smith fell into a neighbor's swimming pool.
3. 76-year-old Eric Baker slipped on a wet bathroom floor.
4. One-year-old Ben Brown put a small toy in his mouth and it lodged in his throat.
5. Kate Green cut his hand badly while opening a tin of peaches.
6. Ten-year-old Jason Gold swallowed some of his father's medicine.
7. 82-year-old Iris Watts dropped a pan of boiling water one her foot.
8. Nick Young suffered cuts, bruises, and a broken arm when he was putting up some shelves in his home.
9. Lee Fenton was hit by a falling tree which he was cutting down.

№ 7 Find in the text and make up word combinations: 1. seek a. resources 2. home b. leaflets 3. simple c. accidents 4. limited d. services 5. advice e. guidelines 6. emergency f. treatment

№ 8. Translate from Russian into English: Станция скорой помощи, несчастный случай дома, отравление, несчастный случай по неосторожности, удушье, утопление, ожоги, падения, несчастные случаи можно было бы предотвратить, ряд информационных листовок по безопасности, полиция, пожарная и скорая помощь.

## Практическое занятие 5. Болезни и их лечение.

№1. Answer the questions.

1. What dairy products do you know?
2. What food is good for people's health?
3. What are the things that help us to keep fit?
4. Which parts of human body can suffer form television and computer?



Herbal tea	toothache
Garlic	a headache
Cranberry jam and drinks	flu

**№4. Match the words and word-combinations with Russian equivalent.**

health -	заботиться о здоровье
bad / poor health —	хрупкое здоровье, ослабленный организм
good health —	регулярные занятия
to be in bad / poor / ill health —	иметь слабое здоровье
to enjoy good health —	придерживаться диеты
to do exercises —	упражняться
regular exercise —	крепкое здоровье
not to take drugs –	не принимать наркотики бегать трусцой
to jog in the morning –	бегать трусцой
to keep to a diet-	придерживаться диеты
to keep fit –	быть в добром здравии

**№5. Try to put the words into the correct column:**

to catch a cold, a scarlet fever, to suffer from, to sound one's heart, to examine, tonsillitis, to recover after illness, to be a chain-smoker, to take one's temperature, a sore throat, to have a running nose, cough, a toothache, to prescribe medicine, to have one's chest x-rayed.

names of diseases	people can	doctors can

**№6. Change the words and make up sentences.**

1. Wealth, is, good, above, health.
2. Healthy, fit, food, to, eat, food, keep.
3. Be, take, a, shower, cool, to, healthy.
4. Your, eat, wash, hands, before, you.
5. Sweets, are, too, bad, many, teeth, for, your.

**№7. Do a crossword connected with parts of body and health.**

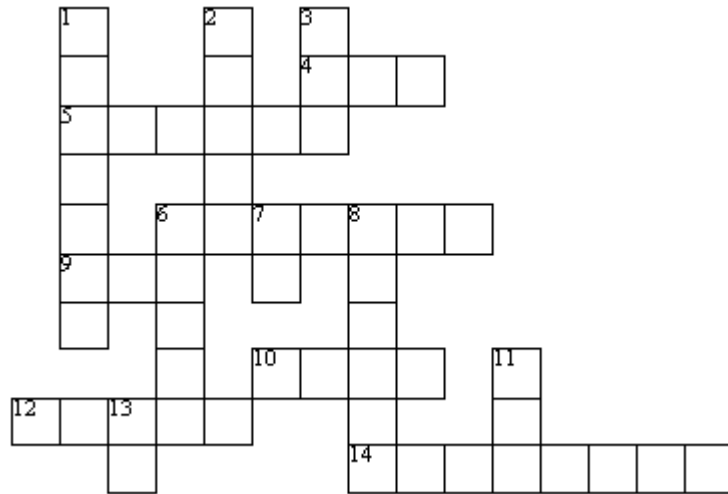

**Across:**

- 4. You use your \_\_\_\_\_ to listen to music.
- 5. Lifting weights makes you \_\_\_\_\_.
- 6. Good food and exercise help you stay \_\_\_\_\_.
- 9. You use your \_\_\_\_\_ to watch a game.
- 10. Candy, potatoes, chips and hamburgers are called \_\_\_\_\_ foods.
- 12. The dentist extracted a bad \_\_\_\_\_.
- 14. Exercising in water \_\_\_\_\_.

**Down:**

- 1. What makes your body parts move?
- 2. Doing something by yourself.
- 3. Use your \_\_\_\_\_ to kick a ball.
- 6. Running and swimming are good for your \_\_\_\_\_.
- 7. In winter we spend much time \_\_\_\_\_ the skating rink.
- 8. It is a sport with rackets \_\_\_\_\_.
- 11. You use your \_\_\_\_\_ to throw a ball.
- 13. What are you complaining \_\_\_\_\_?

**№8. Match the beginning and the ending of the proverbs:**

- |                                   |  |
|-----------------------------------|--|
| 1. Health is                      | a. worse than disease                    |
| 2. An apple a day                 | b. better than a cure                    |
| 3. A remedy is                    | c. the greatest wealth (above wealth)    |
| 4. Early to bed and early to rise | d. catches the worm                      |
| 5. The early bird                 | e. keeps the doctor away                 |
| 6. Prevention is                  | f. in a sound body                       |
| 7. A sound mind                   | g. makes a man healthy, wealthy and wise |

**№9. Put the word-combinations into the columns:**

We must	We must not



--	--

Be healthy; smoke; wash hands; clean the house; eat too much; drink the alcohol; eat the snow; breathe in fresh air; go in for sport; eat fruit and vegetables; do morning exercises; eat too many sweets; go to bed late; keep our body clean; be sleepy; sleep eight hours; visit the doctor regularly; clean the teeth; feel fine; feel sick; have headache; have a bad cold; drink very cold water.

## Практическое занятие 6. Посещение врача.

### 1. New words

doctor - врач

nurse - медсестра

patient - пациент

at the chemist's - аптека

catch cold – подхватить простуду

splitting headache – сильные головные боли

a clogged nose – заложенный нос

a running nose - насморк

to cough - кашлять

to sneeze - чихать

prescription - рецепт

### 2. Read the text and translate it.

#### At the Doctor's

If we caught cold, have a splitting headache, have a clogged nose, cough, are running high temperature, we must go to the polyclinic. First we come to the registry. The registry clerk on a duty asks our name, address, age and occupation. He writes out some slips because several specialists will examine us. Some of them will listen to our heart and lungs, some will check up our kidneys, liver, stomach, eyesight, and hearing. The others will make our blood analysis, take our blood pressure and x-ray us.

Our district doctor sees his patients in consulting room. A nurse gives us a thermometer to take our temperature. We must keep it under an armpit. Last time my temperature was 37,9. The doctor asked what my trouble was. He offered to sit down in a chair and to strip to the waist. He felt my pulse. It was faint and accelerated. Then I lay on the examination couch and the doctor palpated my abdomen. He asked me from what disease I suffered in my childhood. I suffered from scarlet fever. Now I felt dizzy and was damp with sweat. The doctor filled in my card and diagnosed the case as the flu.

Then he wrote out a prescription for some medicines: pills, powder, drops, and mixture. He also advised me to take a scalding footbath, to put a hot water bottle to my feet, to have hot tea with raspberry jam. That would keep my fever down. The result of my x-ray examination and blood analysis was normal. I had the prescription made at the chemist's. I followed the prescribed treatment to avoid complications. Every day I took a tablespoonful of mixture 3 times a day and some pills. In two days I was better and in a week I recovered from my illness. I began to take care of myself. Now I go in for sports because sports make me strong, healthy and cheerful. Every day I do my morning exercises and have a cold rubdown to prevent myself from catching cold. There is a good proverb: An apple a day keeps doctor away. That's why I eat a lot of fruits and vegetables.

In case of sudden and severe illness or an accident calls are made to the first aid station. There the doctors are on duty all day long. There are many ambulances there. The ambulances are equipped with everything necessary to give the first aid. The patient is transported to hospital. There he is taken to the reception ward first. After questioning and examination the doctor fills in

the patient's case history. Then a patient is given special clothes and is put to some ward for treatment. The doctors make their daily round there. They examine patients and prescribe different medicines and treatments.

When a patient is completely cured, he is discharged from the hospital. There are different departments in the hospital. They are: a surgical department, therapy, and the department of infectious diseases.

**Read, translate and act out the following dialogues.**

**Dialogue 1**

- Good morning! Can I help you?
- Good morning! I have a sore throat.
- Is it difficult to breathe?
- Oh, yes, it is. It is difficult to swallow and breathe.
- Do you have a high temperature?
- No, I don't. Have you taken any medicine?
- Not yet.
- When did you fall ill?
- I fell ill two days ago.
- Will you open your mouth and show me your tongue? You are really ill.
- What should I do to get well?
- You should take warm milk with butter or mineral water and buy a good medicine for cold. You will also take vitamins.
- When should I visit you again?
- You will visit me in a week.
- Thank you very much.
- You are welcome.

**Humour**

**The Doctor's Recommendation**

An old gentleman came to see a doctor. The man was very ill. The doctor looked at him and said, "No medicine can help you. If you want to be well again, you must have a good rest. Go to a quiet place for a month, go to bed early, eat more roast beef, drink lots of good rich milk, but don't smoke more than one cigar a day."

A month later the gentleman walked into the doctor's office. He was a different man.

"Oh, doctor," he said. "Thank you very much. Everything is fine and I am well again. But, doctor, it's not easy to begin smoking at my time of life."

- Nurse: Doctor, there's an invisible man in the waiting room.
- Doctor: Tell him I can't see him.
  
- Patient: Doc, I have trouble falling asleep at night.
- Doctor: Well, just lie on the edge of the bed and you'll soon drop off.
  
- Doctor: Did you take my advice about your insomnia? Did you count sheep?
- Patient: Yes I did. I counted to 482,354.
- Doctor: And then did you fall asleep?
- Patient: No, it was time to get up!

## Практическое занятие 7. Спорт. Виды спорта.

### **Sport: is it always healthy?**

Of course, everybody knows about positive influence of sport on people's bodies and minds. Sport educates a strong will, discipline, ability to overcome difficulties. It helps to increase self-confidence and keep fit. It can even be a treatment: sometimes doctors prescribe going in for sport as a cure for people with certain diseases. The proverb of ancient Greeks says "If you want to be beautiful — you should run, if you want to be healthy — you should run, if you want to be clever — you should run", and it is still the truth. So if we take this part of the sport life, everything is brilliant and suitable for you and your health.

But if we take off the pink sun glasses, we'll see that there are some points that are not so fine.

Let's look at the life of professional sportsmen. On one hand, they are full of life, energetic, strong people with good health and big sum of money in the bank. But on the other hand, the essential part of their life is the professional traumas. For example, I can tell you a story of one boxer, named Muhammad Ali. He was the winner of the Olympics in 1960, won 51 out of 56 combats and was told to be the real master of boxing. But the price for that was very high — he got Parkinson disease at the age of 40.

Another problem of the professional sport is so-called dope. It's a helping hand for those, aiming the first places and gold medals, but no one can truly say, that it will bring no harm or it will be no side effects in future. I think everybody has heard about steroids employed by body builders to gain muscles. But have you ever heard that the steroids in very small doses have been used to treat people with mental disturbances, such as schizophrenia and maniac depression for over 50 years. Can you predict what will happen with the body builders in some years? I can't.

One more trouble of professional sportsmen is that they are forced to retire young so there is a great pressure on them. They must win everything they can so they are to keep the strong rules and have got no possibility to make a decision of their own.

If we speak about people who are not crazy about sport, they've got different difficulties. Let's imagine an average person, who is not keen on sport but goes to the gym or swimming pool twice or three times a week. This average man is in danger of overdoing the exercises (because the load is too high). Let alone extreme kinds of sport, which can be really risky without the needed trainings.

In conclusion, I'd like to state that sport itself is neither good nor bad — it depends on the way you do it.

### **Задание 1. Переведите следующие выражения на русский язык:**

Influence, disease, self-confidence, keep fit, pressure, gym, retire, prescribe, mental, disturbances, dope, average

### **Задание 2. Найдите в тексте английские эквиваленты данным ниже русским словам и словосочетаниям**

влиять на (влияние), воспитывать (образовывать), сильная воля, способность, преодолевать трудности, повышать (самооценку) уверенность в себе, быть в форме, лечение, предписывать (о врачах), лечение (лечебное средство), подходящий, принимать участие, заболевание, значительная часть, бой, допинг, стремиться к цели, вред, побочный

эффект, наращивать мышечную массу, давление, строгие правила, возможность, принимать решение, перестараться (переборщить), тренировка, зависеть от.

**Задание 3. Переведите предложения на английский язык.**

- 1) Спорт воспитывает силу воли, дисциплину, способность преодолевать трудности, а также помогает повысить самооценку и быть в форме.
- 2) Иногда врачи советуют заниматься спортом в качестве лекарственного средства при определенных заболеваниях.
- 3) Но, если мы снимем розовые очки, то увидим, что существуют и слабые стороны занятий спортом.
- 4) С одной стороны, вы полны жизни и энергичны, с другой стороны, значительная часть жизни профессиональных спортсменов связана с травмами.
- 5) Чтобы выиграть всё, профессиональные спортсмены должны придерживаться строгих правил, они не могут принимать самостоятельные решения.
- 6) Для обычного человека существует опасность перестараться с упражнениями, так как нагрузка может быть слишком велика.

**Задание 4. Ответьте на вопросы к тексту.**

- 1) What is a positive influence of sport on people?
- 2) What negative sides are in sport?
- 3) What happened to a great boxer Muhammad Ali?
- 4) What harm can dope bring?
- 5) Why are professional sportsmen forced to retire young?
- 6) Why is an average man in danger while going for sport?
- 7) What is your opinion: is sport good or bad?

**Задание 5. Найдите соответствия между словами из первой колонки и из второй.**

1) neck	a) шея
2) shoulders	b) спина
3) chest	c) рука
4) forearms	d) локоть
5) abdominals	e) бедро
6) triceps	f) лопатки
7) lower back	g) талия
8) hamstrings	h) запястье
9) ankle	i) позвоночник
10) arm	j) грудная клетка
11) back	k) плечи
12) calf/shin	l) живот
13) elbow	m) предплечье
14) forearm	n) кончики пальцев руки

15) fingertip	o) предплечье
16) knee	p) туловище
17) leg	q) цыпочки
18) shoulder blades	r) трехглавая мышца плеча
19) hip/thigh	s) брюшной пресс, брюшные мышцы
20) spine	t) лодыжка, щиколотка
21) stomach	u) голень (икра)
22) torso	v) колено
23) tiptoe, tiptoes, tippy toes	w)нога
24) waist	x) низ спины
25) wrist	y) подколенное сухожилие

## Практическое занятие 8. Мой любимый вид спорта.

### Цель:

- закрепление и систематизация теоретических знаний по лексической теме;
- совершенствование навыков перевода текста профессиональной направленности;
- совершенствование навыков поиска информации.

### Прочитайте инструкции по проведению упражнений.

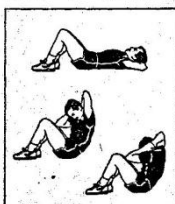
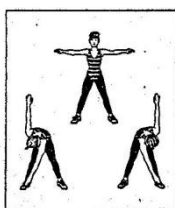

#### Warm-up exercise

Stand with your feet apart and the arms out at shoulder level. Bend forward, twisting the torso at the same time to touch the right hand to the left foot. Stand upright again with the arms out and then bend forward and twist touching the left hand to the right foot. Repeat 10 times on each side the first day and gradually increase to 20 repetitions on each side.

#### Twisting sit-ups

Lie on your back with the legs bent at the knees. You can put the feet under a chair or have someone hold your feet down. Place the hands behind the head. Sit up, twisting at the same time to bring the right elbow to the out-side of the left knee. Lie on your back again. Then sit up and touch the left elbow to the outside of the right knee. Repeat 5 times on each side.

**Задание 1. Найдите в тексте перевод следующих выражений:**

постепенно, довести до 10 упражнений, повторить 10 раз, ноги в разные стороны, на ширине плеч, стать прямо, руки в разные стороны, нагнуться вперед, дотронуться до правой ноги, в обе стороны.

**Задание 2. Найдите соответствия между термином и его определением.**

Parachuting – climbing - ice skating – swimming – tennis –basketball – exercising – field hockey –diving – jogging – golf – horse – riding – bowling – football – aerobics – rugby – hiking – hunting – cycling – baseball – fishing – running – karate - skiing

- 1) An indoor game in which you roll a large heavy ball along a wooden track in order to knock down a group of pins.
- 2) The activity of running slowly as a way of exercising.
- 3) Game played indoors between two teams of five players. Each team tries to win points by throwing a ball into the basket.
- 4) A game in which the players hit a small white ball into holes in the ground with a set of golf clubs, using as few hits as possible.
- 5) The activity in which you jump out of a plane falling slowly and safely to the ground.
- 6) An outdoor game played by two teams with an oval ball that you kick or carry.
- 7) The activity of riding a bicycle. Physical activities that you do in order to stay healthy and become stronger.
- 8) The sport or activity of riding horses.
- 9) The sport of moving yourself through water using your arms and legs.
- 10) The sport of moving down hills or across land in the snow wearing skis.
- 11) The sport or activity which is similar to jogging but moving much faster.
- 12) The activity or sport in which you move quickly on ice.
- 13) The game played by two teams of eleven players who try to kick a round ball into the other team's goal.
- 14) The sport of going up mountains or rocks.
- 15) The sport of swimming under water using special equipment to help you breathe
- 16) An activity in which you chase and kill animals for food or sport.
- 17) The sport or business of catching fish.
- 18) A game for two people or two pairs of people who use rackets to hit a small soft ball backwards and forwards over a net.
- 19) A type of physical exercise you do listening to music.
- 20) An outdoor game between two teams of nine players, in which players try to get points by hitting a ball and running around four bases.
- 21) A game played on grass by two teams of 11 players, with sticks and a ball.
- 22) A Japanese fighting sport, in which you use your feet and hands to hit and kick.
- 23) The activity of taking long walks in the mountains or country.

**№2. Match numbers and letters**

- |             |                   |
|-------------|-------------------|
| 1. arrow    | a. hockey         |
| 2. skittles | b. baseball       |
| 3. skates   | c. fencing        |
| 4. foil     | d. tennis         |
| 5. puck     | e. gymnastics     |
| 6. bat      | f. archery        |
| 7. racket   | g. ice dancing    |
| 8. hoop     | h. weight lifting |
| 9. ring     | i. bowling        |

10. dumb-bell            j. boxing

**№3. Match the sport with the location:**

- |                |            |
|----------------|------------|
| a) golf        | 1. rink    |
| b) boxing      | 2. pool    |
| c) tennis      | 3. stadium |
| d) swimming    | 4. field   |
| e) football    | 5. court   |
| f) athletics   | 6. ring    |
| g) ice-skating | 7. course  |

**№4. Write a person of the different sports.**

judo, boxing, baseball, ice dancing, tennis.

**№5. Find the words for these categories:**

sport	sportsman	equipment	activity	skills

swimming, ball, athlete, hockey, ride, field, fast, gymnast, energetic, jump, windsurfing, strong, go, runner, courageous, track, figure skater, play, golf, rink, basketball, bike, mountaineer, patient, pool.

**№6. Translate the words.**

лёгкая атлетика, настольный теннис, прыжки в длину, велоспорт, подводное плавание; canoeing, cycling, snooker, equestrian sport, mountaineering.

**№7. Match the sport and the description**

- |             |   |
|-------------|---|
| 1. tennis   | a) is done in water                     |
| 2. jogging  | b) a boat is needed for it              |
| 3. swimming | c) is a team sport                      |
| 4. fencing  | d) is played by two or four with a ball |
| 5. skiing   | e) can be done alone                    |
| 6. skating  | f) can only be done by two              |
| 7. rowing   | g) wind is necessary                    |
| 8. hockey   | h) is done on ice                       |
| 9. sailing  | i) swords are used for it               |
| 10. boxing  | j) snow is necessary for it             |

**№8. Crossword Sports. Write what they do and find the girl's name.**

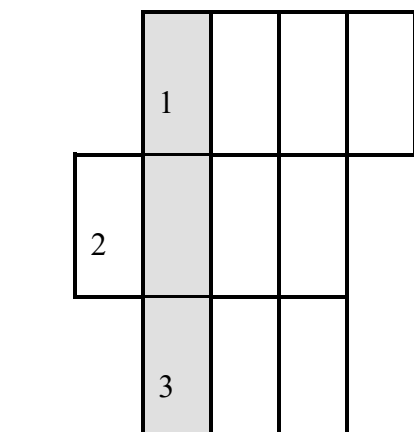

4				
5				

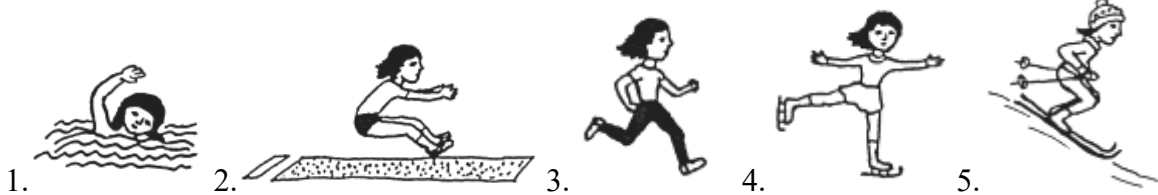

This girl likes sports.  
Her name is \_\_\_\_\_

**Read, translate and act out the following dialogue.**

**Dialogue 1**

A: Hi, Jack. Did you watch football match yesterday?

B: Yes, I did.

A: What was the final score?

B: Our team lost the game.

**Dialogue 2**

A: What's your favorite sport?

B: I am fond of swimming.

A: Are you a professional sportsman?

B: Oh, yes, my team participates in international competitions.

A: Who is the coach of your team?

B: Mr. Tom Jones

**Dialogue 3**

A: What is the most popular sport game in your country?

B: It's football. I am a sports fan, that's why I know everything about this game.

**Dialogue 4**

A: Hello, Alex. Do you have tickets for today's game?

B: Yes, I have one. Last competition was marvelous. Our team won a cup.

A: I hope they will win today's game and will keep the score. Where will the competition be held?

B: It'll be held at the central stadium of our city.

**Dialogue 5**

A: Which winter sports do you like?

B: I like skating. We have a skating-rink in our yard every winter, and I skate there every day after technical school. And which sports do you like in winter?

A: Well, I like skiing very much. Every Sunday my father and I take our skis and go skiing in the country all day.

B: Isn't it very cold to go skiing all day?

A: No. I enjoy it greatly. You are very warm when you go skiing in cold weather.



B: Don't you like ice hockey?

A: I like to watch ice hockey matches, but I don't play. I only have skis.

B: Do you watch hockey matches on TV?

A: Oh, yes, of course. Our Russian hockey team is splendid, isn't it? It has won the world hockey cup and the Olympic championship many times.

B: I think that is because a lot of Russian boys play hockey.

### **Learn by heart**

#### **Sport**

Sport is fun for girls and boys  
It's much better than the toys.  
You can sledge and ski, and skate  
And play snowballs with Kate.  
You can swim and play football,  
Hockey, tennis, basketball.  
You can jump and you can run  
You can have a lot of fun.

#### **Basketball's My Favorite Sport**

Basketball's my favorite sport.  
I dribble up and down the court.  
The ball goes bouncing off my toes  
and beans the teacher on the nose.  
He stumbles back and grabs his nose  
and hits the wall and down he goes.  
The other players stop and stare.  
They've never heard the teacher swear.  
With no one playing anymore.  
I grab the ball. I shoot. I score.  
I love this game! It's so much fun.  
The teacher cried, but, hey--we won.  
Kenn Nesbitt

## Практическое занятие 9. Спорт в России и Великобритании. Выдающиеся спортсмены.

### **№1. Answer the questions:**

1. What kind of sport do you know?
2. What traditional Russian games do you know?
3. What sports and games are most popular in Russia now?
4. What sports are new or uncommon in this country?
5. What summer and winter sports do you know?
6. What sports would you enjoy most? Why?
7. What famous Russian and foreign athletes do you know? In what sports did they become famous?
8. What sports are the most dangerous and the least dangerous?
9. What water sports do you know?

10. What team games do teenagers usually play in Russian schools?
11. Why is it necessary for teenagers to go in for sport?
12. Are there enough stadiums, gyms and swimming baths in the place where you live?
13. What can local and national governments do to make sport more popular?

**Задание 2. Заполните пропуски в тексте данными ниже словами**

- 1) health;
  - 2) subject;
  - 3) care;
  - 4) includes;
  - 5) competitions;
  - 6) popular;
  - 7) catch;
  - 8) interested;
  - 9) participants;
  - 10) sports grounds;
  - 11) gymnastics.
- 2)

### **PHYSICAL EDUCATION IN RUSSIA**

Sport is very important in our life. It is... a)... among young and old people.

Physical education is an important... b) ... at colleges. Students have got physical training lessons once a week. They play volley-ball and basket-ball in the sport grounds. There are... c)... at the students campus and students go in for sports in the open air.

A lot of different... d)... are held at universities, a great number of students take part in them. All... e)... try to get good results and become winners. Sport helps people to keep in good... f)... If you go in for sports, you have good health and don't... g)... colds.

Children and grown-ups must take... h)... of their health and do morning exercises regularly.

There are some popular kinds of sports in our country: football, volley-ball, hockey,... i)..., skiing, skating. Athletics is one of the most popular kinds of sports. It... j)... such kinds of sports as running, jumping and others. Everybody may choose the sport he (or she) is... k)... in.

### **Texts for reading**

#### **Extreme sport**

Skateboarding was developed in the USA. California in the 1960s and became a craze in the 1970s. Skateboarding has enjoyed a revival since the late 1980s when teenagers started to form communities of skateboarders with their own values, beliefs and special activities, such as skateboarding shows. Since then it has become an extreme sport rather than a hobby, because now skateboarders practice ramp and rail skateboarding.

Scuba diving has become very popular recently. Many years ago participants were predominately young men. Today this sport is enjoyed by people in all age groups, men, and women, and even teenagers. Just about any teenager or adult who enjoys the water and can swim, and who neither does nor have heart or long problems, can learn to scuba dive. It does not take great physical strength. All it takes is the desire, some basic classroom and in water training.

It's becoming very popular in Russia.

For extreme divers there are several ways they can go under water (breath-hold, helmet diving, submarine.). Diving with scuba signifies using an apparatus that is completely carried by the diver and nor connected to the surface.

## **National sports of Great Britain**

Many kinds of sport originated from England. The English have a proverb, "All work and no play makes Jack a dull boy". They do not think that play is more important than work; they think that Jack will do his work better if he plays as well. so he is encouraged to do both. Association football, or soccer is one of the most popular games in the British Isles played from late August until the beginning of May. In summer the English national sport is cricket. When the English say: "that's not cricket" it means "that's not fair", "to play the game" means "to be fair".

Golf is Scotland's chief contribution to British sport. It is worth noting here an interesting feature of sporting life in Britain, namely, its frequently close connections with social class of the players or spectators except where a game may be said to be a "national" sport. This is the case with cricket in England which is played and watched by all classes. This is true of golf, which is everywhere in the British Isles a middle-class activity. Rugby Union, the amateur variety of Rugby football, is the Welsh national sport played by all sections of society whereas, elsewhere, it too is a game for the middle classes. Association football is a working-class sport as are boxing, wrestling, snooker, darts, and dog-racing. As far as fishing is concerned it is a sport where what is caught determines the class of a fisherman. Walking and swimming are the two most popular sporting activities, being almost equally undertaken by men and women. Snooker (billiards), pool and darts are the next most popular sports among men. Aerobics (keep-fit exercises) and yoga, squash and cycling are among the sports where participation has been increasing in recent years.

There are several places in Britain associated with a particular kind of sport. One of them is Wimbledon where the All-England Lawn Tennis Championship is held in July (since 1877). The other one is Wembley - a stadium in north London where international football matches, the Cup Finals and other events have taken place since 1923.

### **Table tennis**

Table tennis was first invented in England in about 1880. At first the game had several strange names: Gossima. Whiff Whaff and Ping Pong. It wasn't until 1926 that the International Table Tennis Association was formed with international championships and rules.

Although the game was invented in England British players don't have much chance in international championships. It's the Chinese with their fantastic speed and power who win almost every title. Table tennis looks more like gymnastics when the Chinese start playing, with the ball flying over the net at speeds of over 150 kilometres per hour.

### **Racing**

There are all kinds of racing in England - horse-racing, motor-car racing, boat-racing, dog-racing, and even races for donkeys. On sports days at school boys and girls run races, and even train for them. There is usually a mile race for older boys, and one who wins it is certainly a good runner. Usually those who run a race go as fast as possible, but there are some races in which everybody has to go very carefully in order to avoid falling. The most famous boat-race in England is between Oxford and Cambridge. It is rowed over a course on the River Thames, and thousands of people go to watch it. The eight rowers in each boat have great struggle, and at the end there is usually only a short distance between the winners and the losers. The University boat-race started in 1820 and has been rowed on the Thames almost every spring since 1836.

### **Squash**

Squash began at Harrow School in the mid-nineteenth century, but has since worked its way into almost every city and district in Britain and throughout Europe.

Squash is one of the fastest games in the world. Two people play in a small confined space surrounded by high walls with no net to keep them apart. The aim is to get to the point at the centre of the court and to stay there. Squash players hope that the game will make them stronger and fitter, but like many sports, squash can be very dangerous. The most obvious danger is the small ball that shoots through the air extremely fast.

### Windsurfing

Windsurfing was invented in the mid-sixties by two southern Californian surfers, Hoyle Schweitzer and Jim Drake. Surfers need strong rolling waves, and hate days of calm sea. Schweitzer noticed that on days when waves were not high enough to surf, there was often a strong wind and he set about finding a way to use it.

His first experiments involved standing on his surfboard holding out a piece of sail cloth in his hands. Gradually he and Drake refined this idea into a basic design for a sailboard, similar to a surfboard, but holding a mast and a triangular sail which could be tilted and turned in any direction. The windsurfer operates a boom which controls the amount of wind in the sail, for speed and change of direction. Schweitzer immediately went into business designing and making the new sailboards and taking the idea abroad. By mid-seventies, the sport had spread to Holland, Germany and France.

Tatyana Tarasova	
Her biography facts	<p>The daughter of a famous ice hockey trainer</p> <p>Lived and worked in the USA for more than a decade</p> <p>Returned to Russia in 2006</p>
Her athletic career	<p>Began to do skating at the age of 5</p> <p>Got a trauma</p> <p>Had to end her career at the age of 18</p>
Her trainer career	<p>Started training young athletes at the age of 19</p> <p>Did what she could to keep Russian figure skaters in good form for the future of national figure skating</p>
Her achievements	<p>Trained more world and Olympic champions than anybody else in skating history</p> <p>11 of her students are Olympic champions</p> <p>Her students won about 50 gold and a lot of silver and bronze medals at different competitions</p>
Her secret of success	<p>Knows everything about figure skating</p> <p>Every little detail is important for her</p>

## Практическое занятие 10. Обобщение лексического и грамматического материала.

game - игра  
to develop physically – развивать физически  
make smb organized – делает кого-либо организованным  
make smb disciplined – делать кого-либо дисциплинированным  
amateur club – любительский клуб  
keep-fit center – спортивный центр (тренажёрный зал)  
track-and-field – лёгкая атлетика  
competition – соревнование  
sportsman - спортсмен

### 2. Read the text.

All over the world people of different ages are fond of sport and games. Sport not only helps people to become strong and to develop physically but also makes them more organized and better disciplined in their daily activities. In every town there are amateur clubs and keep-fit centers, where people can do aerobics, body-building or work with different training devices.

There are a lot of different kinds of sport: football, basketball, volleyball, tennis, track-and-field, water polo and many others. The main sport competition is the Olympic Games.

The Olympic Games have a very long history. They began in 777 BC in Greece and took place every four years. For the period of the Games all the wars stopped. So the Olympic Games became the symbol of peace and friendship. In 394 AD the Games were abolished. In 1894, a Frenchman, Baron Pierre de Coubertin, addressed all the sports governing bodies and pointed out the educational value of sports. Two years later the first modern Olympic Games took place in Greece to symbolize the centuries old tradition. Russia joined the Olympic movement in 1952. In 1980 Moscow hosted the Twenty-Second Olympic Games. The latest Olympic Games were held in Sydney. Sydney was the host for the Games of the 27th Olympiad in 2000. About 200 countries took part in the competitions. There were 10000 athletes and 5000 officials. There were 27 sports on the program for the 2000 Olympic Games. Triathlon and Taekwondo were included in Sydney for the first time at any Olympic Games. Our Russian team took part in the Olympic Games too, we were the second in the overall count of won medals, after the USA team.

As for me, I like sport very much, but I like sport not only as a sport fan, but also as a sportsman. I had been training judo for 9 years and I had not much time to train. But I don't stop to go in for sport: sometimes in the morning or in the evening I run and sometimes I visit keep-fit center (trainer hall).

### Переведите, используя конструкцию *be going to*.

1. Когда ты собираешься позвонить ему?
2. Уже 7 часов! Ты опоздаешь на поезд!
3. Куда ты собираешься?
4. Когда она собирается увидеться с гостями?
5. Собираемся ли мы прочитать этот текст?
6. Шон не слушается своих родителей. Я думаю, что скоро они накажут его.
7. Я не буду готовить обед сейчас. Я отдохну немного, а потом что -нибудь приготовлю.
8. Она собирается найти работу.
9. Они собирались работать на выходных, но потом решили встретиться с друзьями.
10. Она собиралась идти на вечеринку, но ее отец не пустил ее.

### Complete the sentences with verbs in the Present Simple (*I work*), the Present Continuous

**(I'm working), the Past Simple (I worked), the Present Perfect (I've worked), or will/might + verb (I'll work, I might work).**

**Example** Yesterday I **watched** (*watch*) football on TV.

Matt Bradly is only 15 years old but he's already very, very rich. Two years ago Matt (1) \_\_\_\_\_ (begin) a football website for 12-16-year-olds.

"I (2) \_\_\_\_\_ (become) interested in computers when I (3) \_\_\_\_\_ (be) about eight because my father's job is with computers. As a little boy I also (4) \_\_\_\_\_ (love) football and so I (5) \_\_\_\_\_ (decide) to make a website especially for people of my age."

Matt (6) \_\_\_\_\_ (start) the "Football OK!" website two years ago, and now more than 20,000 people (7) \_\_\_\_\_ (visit) it every day.

Matt is half a schoolboy and half a businessman. He usually (8) \_\_\_\_\_ (get up) at six o'clock and (9) \_\_\_\_\_ (look) through his e-mails. Then he (10) \_\_\_\_\_ (go) to school from nine to four. In the evenings he always (11) \_\_\_\_\_ (work) for about four hours on his website.

Matt's next project is a new website: "At the moment I (12) \_\_\_\_\_ (think) about a new website on American football, maybe for next year."

And is Matt the same person he was three years ago? "No, I'm very different now. I (13) \_\_\_\_\_ (already/meet) a lot of interesting people on the website and I (14) \_\_\_\_\_ (travel) all over the world."

Matt (15) \_\_\_\_\_ (not/know) about the future. "I (16) \_\_\_\_\_ (sell) the websites, I really don't know. I'll just wait and see."

One thing is certain: when he's 21 Matt (17) \_\_\_\_\_ (be) a millionaire!

*Употребите один из случаев выражения будущего времени в предложениях. Объясните свой выбор.*

**A. will** — действия в будущем, которые мы не можем изменить; констатация фактов; ожидание, надежда; спонтанное решение.

**B. Present Simple** — расписание (поездов, самолетов, автобусов, уроков, лекций, фильмов, и т.п.);

**C. Present Continuous** — запланированное действие в ближайшем будущем: личная договоренность с людьми.

1. We (have) a party next Saturday. Would you like to come?
2. I (not/go) away for my holidays next month because I haven't got enough money.
3. The concert (start) at 7.30 in the evening.
4. George, is it true that you (get married) next week?
5. The art exhibition (open) on 3 May and (finish) on 15 July.
6. What time ... the next train (leave)?

7. Ann, we ... (go) to town, ... you (join) us?
8. I (have) lunch with some businessmen next Wednesday.
9. My Uncle John from America (visit) us soon.
10. The examinations (take place) next month as announced.

#### Раздел 4. Путешествие. Поездка за границу

### Практическое занятие 11. Виды транспортных средств.

**Задание 1.** Напишите, какие слова, имеющие отношения к транспорту, здесь зашифрованы.

- |           |                |
|-----------|----------------|
| 1) ryref  | 4) yfl         |
| 2) nepal  | 5) rotllyebisu |
| 3) wsbuya | 6) nrtai       |

2. Выучите новую лексику

#### I. Means of Transport (Средства транспорта):

1. means of transport — средство транспорта (ед., мн.ч)
2. vehicle[ˈvi:ɪkl] — средство передвижения
3. balloon — воздушный шар
4. helicopter — вертолет
5. plane/ airplane — самолет
6. car/ taxi — машина/ такси
7. bus/ coach — автобус рейсовый/ экскурсионный
8. double-decker bus — двухэтажный автобус
9. van / lorry — фургон/ грузовик
10. train — поезд
11. underground — метро
12. ship — корабль
13. ferry — паром
14. yacht [jɒt] — яхта
15. bike/ motorbike — велосипед/ мотоцикл

#### II. Transport Verbs:

16. reach / get to — добраться до
17. arrive in/at — прибывать в (большой город / место)
18. go on foot / walk — идти пешком
19. go by car/ bus/ etc. — ехать на машине
20. cycle [ˈsaɪkl] — ехать на велосипеде
21. drive a car — водить машину
22. ride a bike/ a horse — кататься на велосипеде/ лошади
23. sail — плыть под парусом
24. fly — лететь
25. hitchhike — путешествовать автостопом

#### III. Collocations (устойчивые сочетания):

26. go by car (taxi, etc.) — ехать на машине (такси, и т.д.)
27. go on foot — идти пешком
28. go on a trip — отправиться в поездку
29. take a taxi — взять такси
30. catch a bus/ a train — успеть на автобус/ поезд
31. miss a bus/ a train — опоздать на автобус/ поезд
32. get on a bus/ a train — сесть в автобус/ поезд
33. get off a bus/ a train — сойти с автобуса/ поезд
34. get into a car/ a taxi — сесть в машину / такси
35. get off a car/ a taxi — выйти из машины/ такси
36. go hitchhiking [ˈhɪtʃhaɪkɪŋ] — путешествовать автостопом
37. it takes me (...) to get to — Мне требуется (время), чтобы добраться до ...

**Read the text and answer the questions.**

### Travelling

Millions of people all over the world spend their holidays travelling. They travel **to see other countries and continents, modern cities and towns**. It is always interesting to discover new things, **to meet different people, to try different food**, to listen to different music. Those who live in the country like to go to a big city and **spend their time visiting museums and art galleries, looking at shop windows and dining at exotic restaurants**. People like to **walk and bathe and laze in the sun**. Most travelers take a camera with them and **take pictures - lakes; waterfalls**, different kinds of trees, flowers and plants; animals and birds.

People travel by train, by boat and by car. All means of travel have their advantages and disadvantages. And people choose one according to their plans and destinations.

If we are fond of travelling, we see and learn a lot of things that we can never see or learn at home, though we may read about them in books and newspapers, and see pictures of them on TV. The best way to study geography is to travel, and the best way to get to know and understand the people is to meet them in their own homes.

1. What do people travel for?
2. How do people living in the country spend their holidays?
3. What do city people like?
4. What do most travelers take a camera with them for?
5. How do people travel?

## Практическое занятие 12. Советы путешественнику.

**№1 Choose a question word from the box and write the complete question.**

Why    What (x 2)    How far    How    When    How often    How many    Where  
How long

**Example :** you/like/doing/in your free time? – What do you like doing in your free time?



1. this shop/open?

---

It opens at nine o'clock.

2. Tom/want/for his birthday?

---

He wants a guitar.

3. you/go swimming?

---

I usually go three times a week, on Monday, Wednesday and Friday.

4. people/be/there/in your class?

---

Twenty-four.

5. the toilet?

---

It's over there.

6. can I/get/to the airport/from here?

---

You can go by underground or take a bus.

7. the journey/take?

---

It took ten hours.

8. you/do/this weekend?

---

We're going to stay with some friends.

9. be/it/from here/ to the city centre?

---

It's about six kilometers.

10. you/be/late?

---

Because there was a traffic jam.

**1. Look at the sentences below about a journey to the Arctic on board a ship.**

**Read the text that follows and decide if each sentence is correct or incorrect.**

**If it is correct, mark *A* on your answer sheet.**

**If it is not correct, mark *B* on your answer sheet.**

1. The trip is for people who like peace and quiet.
2. Many different activities are organized on board.
3. The voyage begins in Scotland.

4. The ship follows a fixed route.
5. There are different types of accommodation.
6. Passengers serve themselves in the dining room.
7. Whales can be seen in the morning near Tromsø.
8. There are some examples of traditional buildings in Tromsø.
9. The ship stays overnight in Tromsø.
10. Bear Island used to be a busy fishing center.

### **Exploring the Arctic**

The Arctic is one of the few places in the world untouched by pollution where you can see nature at its wildest and most beautiful. Join our ship the *Northern Star* from 2 to 18 July, for a 17 – day voyage to the Arctic. During the voyage you are able to relax and get away from it all. There are no parties or film-shows to attend, quizzes to enter, or entertainers to watch. However, we do have specialists on board who are willing to answer any of your questions about the Arctic and who will talk about the animals and birds that you see on the trip.

After setting off from Scotland, we go north along the coast of Norway to Bear Island. Along the way you'll see thousands of seabirds and wonderful scenery, with rivers of ice and huge cliffs. You will have the chance to see reindeer, polar bears, and other Arctic animals. Although we have a timetable, experience has shown that we may have to change our direction a little, depending on the weather and on which animals appear.

The *Northern Star* is a very special ship and our past voyages have been very popular. Our cabins all have the same excellent facilities, which include a private bathroom and refrigerator. Our chefs are happy to prepare any food for people on special diets. Choose just what you want to eat from the wide variety available from the dining room buffet. There is a library, shop, clinic, and plenty of space for relaxation. If you need some exercise, why not go jogging every morning around the decks, or do some swimming in the indoor pool.

Prices include economy class air travel and 16 nights on board the *Northern Star*, all meals and all excursions and all lectures.

Day 1	Board the <i>Northern Star</i> .
Days 2-7	We sail slowly north along the coast of Norway, stopping at places of interest.
Day 8	Tromsø. You need to get up at sunrise to see the whales as we sail towards Tromsø. Visit Tromsø to see the Arctic Museum, the cathedral and the beautiful old wooden houses. In the evening we sail away along the west coast to Bird Island, which is excellent for bird-watching.
Days 9-10	Bear Island. We arrive here in the early evening and stay overnight. Bear Island once had an active fishing industry, but today little of this remains. We will explore the island, looking for Arctic flowers.
Days 11-16	Spitsbergen. A place of mountains and rivers of ice, it is home to a large variety of animals.

Day 17

Leave the ship in Spitsbergen and fly to London from Tromsø.

**2. Дайте совет путешественникам, отправляющимся в путешествие по Арктике.**

Write **should or shouldn't** in the sentences about travelling.

1. You \_\_\_\_\_ take a map.
2. You \_\_\_\_\_ make much noise on a train.
3. You \_\_\_\_\_ touch wild animals.
4. You \_\_\_\_\_ help your friends.
5. You \_\_\_\_\_ visit museums.
6. You \_\_\_\_\_ take your toothbrush.
7. You \_\_\_\_\_ be careful.

**Choose the correct alternative:**

1. You *must / should / shouldn't* be 18 before you can drive in Spain.
2. You *don't have to / mustn't / shouldn't* go to bed so late. It's not good for you.
3. You *don't have to / mustn't / shouldn't* wear a school uniform in most Spanish state schools.
4. You *must / mustn't / needn't* come. I can do it without you.
5. You *don't have to / must / mustn't* copy during exams.
6. You *don't have to / mustn't / shouldn't* be very tall to play football.
7. You *must / mustn't / needn't* be a good writer to win the Pulitzer Prize.

Практическое занятие 13. Отправляемся в путешествие: бронируем номер в отеле.

**Answer the questions**

- 1) Do you like traveling?
- 2) What is your favourite city or town?
- 3) Do you like traveling by plane/by car/by bus?
- 4) Where did you go on holiday last year?
- 5) Where do you want to go next year?
- 6) What is your mother town?
- 7) What is your favourite place in your mother town?
- 8) What winter holidays do you know?
- 9) What is your favourite holiday?
- 10) What presents do you usually buy for your family?

**Задание 1. Прочитайте диалоги людей, остановившихся в гостинице Royal, и заполните пропуски в диалогах фразами, данными в рамке.**

Excuse me  
Have you got a single room or a double room?  
Can you complete this form, please?  
How long are you here for?  
forty pounds a night  
Here's your key.  
Three nights.

**Dialogue 1. In the corridor**

**Mr Lewis:** 1) \_\_\_\_\_, is there a phone here?

**Mrs Thomson:** Yes, there's one near reception. 2) \_\_\_\_\_, turn left and it's on your right.

**Dialogue 2. At the swimming pool**

**Jo:** 3) \_\_\_\_\_?

**Nur:** A week and then we go back to Istanbul. And you?

**Jo:** 4) \_\_\_\_\_. What's your room like? Mine's very small.

**Nur:** My room is OK. 5) \_\_\_\_\_?

**Jo:** Single. I'm here with my friend, Jackie. She's got a single room, too.

**Nur:** Some of the single rooms are small here.

**Jo:** Yes, and they cost a lot of money, 6) \_\_\_\_\_

**Dialogue 3. At the hotel reception**

**Mr Smith:** Good morning. Mr and Mrs Smith. We're here for four nights.

**1.Прочитайте и переведите текст «Types of hotels: target Markets»:**

Hotel targets many markets and can be classified according to the markets they attempt to attract their guests. Common type of markets include business, airport, suites, residential, resort, timeshare , casino , convention and conference hotels .

- **Business Hotels:** - These hotels are the largest group of hotel types and they primarily cater to business travelers and usually located in downtown or business districts. Although Business hotels primarily serve business travelers, many tour groups, individual tourists and small conference groups find these hotels attractive. Guest amenities at business hotels may include complimentary newspapers, morning coffee, free local telephone calls, Breakfast etc.
- **Airport Hotels:** - These types of hotels typically target business clientele, airline passengers with overnight travel layovers or cancelled flights and airline crews or staff. Some hotels might give free transport between hotel and airport. Some Airport hotels also charges the guest by hour instead of normal daily night charges.
- **Suite Hotels:** - These kind of hotels are the latest trend and the fastest growing segments in the hotel industry. Such hotels have a living room and a separate bedroom.

Professionals such as accountants, lawyers, business men and executives find suite hotels particularly attractive as they can work and also entertain in an area besides the bedroom.

- **Extended Stay Hotels:** - Extended stay hotels is somewhat similar to the suite hotels , but usually offers kitchen amenities in the room . These kinds of hotels are for long stayers who wants to stay more than a week and does not want to spend on hotel facilities.
- **Serviced Apartments:** - Serviced Apartment / Residential hotels provide long-term or permanent accommodation for Guest. Usually guest makes a lease agreement with the hotel for minimum of one month up to a year. Rooms generally include living room, bedroom, kitchen , private balcony , washing machines , kitchen utensils etc. Unlike normal hotels Serviced apartment only provide weekly one housekeeping service.
- **Resort Hotels:** - Resort hotels are usually located in the mountains, on an island, or in some other exotic locations away from city's. These hotels have recreational facilities, scenery , golf , tennis , sailing , skiing and swimming . Resort hotels provide enjoyable and memorable guest experiences that encourage guest to repeat to the resort.
- **Bed and Breakfast / Homestays:-** These are houses with rooms converted into overnight facilities , this can size up to 1 to 10 guest rooms . They are also known as 'Home Stay's'. The owner of the B&B usually stay on the premises and is responsible for serving breakfast to guest .
- **Timeshare / Vacation Rentals:** - Another new type or segment of the hospitality industry is the timeshare hotels. These are sometimes referred to as "Vacation-interval" hotels . Timeshare hotels are where the guests who purchase the ownership of accommodations for a specific period. These owners may also have the unit rented out by the management company that operates the hotel.
- **Casino Hotels:-** Hotels with gambling facilities are called Casino Hotels .Although the food and beverage operations in casino is luxurious their functions is secondary to and supportive of casino operations.
- **Conference and Convention Centres:** - These type of hotels focus on meeting and conferences and overnight accommodation for meeting attendees. They also provide video confrencing facility, audiovisual equipments, business services, flexible seating arrangements , flipchart etc. These hotels mostly located outside the metropolitan areas and have facilities like golf , swimming pools , tennis courts , fitness centers , spas etc.

2. Сформируйте глоссарий к тексту (20 слов).

3. Вставьте в сложноподчинённые предложения союзы по смыслу *but, although, however, so или because*:

1) I like eating, \_\_\_\_\_ I don't like cooking. 2) I didn't telephone her \_\_\_\_\_ I didn't have her number. 3) It was his birthday \_\_\_\_\_ I bought him a present. 4) I love dancing \_\_\_\_\_ , I'm not going to the disco. 5) he's very young he plays the piano extremely well. 6) She offered me some cake, \_\_\_\_\_ I wasn't hungry.

4. Объедините предложения двумя способами, употребив *so* и *because*.

1) She went home. She was tired. 2) We didn't enjoy our holiday. The weather was bad. 3) He worked hard. He passed all his exams. 4) I enjoy history lessons. I like the teacher. 5) It started to rain. We stopped playing tennis.

## Практическое занятие 14. Плюсы и минусы разных транспортных средств.

### №1. Learn the following words

To get (go) by bus	добираться ( ездить ) на автобусе
to get by coach to a remote place	добраться на автобусе в отдалённое место
to get on a bus	сесть на автобус
to catch a bus	успеть на автобус
to book a single ticket	заказать билет в один конец
to miss a bus	опоздать на автобус
accommodation	размещение
advantage	преимущество
arrange	устраивать
book	бронировать, заказывать
disadvantage	недостаток
enjoy	наслаждаться
journey	путешествие
luggage	багаж
make a fuss	суетиться, беспокоиться
take trouble	волноваться. заботиться
tiresome	утомительный

## **№2. Read and learn**

### **Travelling by Bus**

Nowadays buses are becoming more and more comfortable. Some years ago I didn't like travelling by bus, but now I enjoy it. My parents and I don't travel abroad for long distance by bus. Usually it takes us several hours to get to the place which we want to visit. Modern coaches are very comfortable. There is a video and a toilet. We can have hot tea or coffee or a snack. It's very pleasant to sit comfortably looking through the window. Sometimes we have excursions and the guide tells us very interesting information about the historical places which we pass by.

During our trips we often have stops. As for me I like walking during such breaks. Travelling by bus we have visited a lot historical sights of our country. Now I can see in what wonderful country I live!

**You are fond of travelling by bus, aren't you? Please write a composition "Travelling by Bus"**

1. Is it comfortable for you to travel by bus?
2. Do you like to use this method of travelling? Why?
3. Where do you prefer to have such trips?
4. How often and with whom do you travel by bus?
5. Have you ever gone abroad by bus? Where? Did you like it? How did you spend your time during your trip?
6. Do you like to have bus excursions to see historical sites of the country?
7. What are the advantages and disadvantages of such trips?
8. Where do you usually have meals when you travel by bus?
9. Can you rest and have a good time during such trips?
10. Where are you going to travel by bus next time?

### **Travelling by Car**

Many people say that they prefer travelling by car. There are some advantages and disadvantages.

First, what advantages are there? We don't have to buy tickets, only petrol. We don't need suitcases, we can put our luggage into the car. We can take as many things as we want. We can stop and have a break practically anywhere we like. We can spend a night in the car or stay in a hotel. When we travel we can listen to music in the car. In cities and towns we don't need public transport. We can go sightseeing in the car.

Here are some words about disadvantages. Petrol is very expensive. It costs serious money to get from one city to another. There are a lot of traffic jams. It's very difficult to find a place to park in the city. Some drivers like speeding, so driving can be dangerous for others. That's why there are a lot of car crashes nowadays.

As for me, I like travelling by car for not very long distances. My father is a very good driver. He never speeds. When the weather is fine we like to go to the nearest towns and cities. We are fond of history and sightseeing. We always enjoy travelling by car!

**Do you like travelling by car? Please answer these questions and write a composition "Travelling by Car"**

1. Why do many people prefer travelling by car?
2. Can you say that travelling by car is your favourite way of travelling? Why?
3. Has your family got a car? How often do you travel? Where?

4. Where do you like to travel by car?
5. Where did you last go to? What sights did you see? Did you enjoy it?
6. What do you usually take when you go by car?
7. Where do you stay at night? Do you usually spend nights in the tent or stay at the hotel
8. Do traffic jams make you nervous?
9. Do you suffer from car-sickness?
10. Where are you going to travel by car? With whom? What sight are you going to see? Are you looking forward to this trip?

**Listen to the dialogue and answer the questions below**

Sasha: Can your father drive

Max: Yes, he can. He is a very experienced driver and never speeds. I want to learn driving and get driving license then I'm 18

Sasha: So do I. I'm fond of driving. It's my dream. Do you travel by car?

Max: Sometimes we do. Not for long distances. Every weekend we go to the country, our grandparents live there and we have to take some products.

Sasha: My dad wants to take us abroad by car. It is his dream to travel around Italy by car

Max: I think it will be a wonderful trip. But, of course, it's very difficult to drive for hours.

Sasha: Yes, but my mum can drive. Sometimes she will.

Max: I want to visit Italy, too.

**Questions to the dialogue**

How well can Max's father drive?

What does Max want to learn when he is 18?

Where do Max and his family usually drive?

Where does Sasha want to travel by car?

Whose mum can drive?

**Travelling by train**

As for me, I'm fond of traveling by train. I like everything. Of course, it isn't so fast as traveling by plane, but I can get to the most remote place. And it's cheaper than travelling by plane. My parents and I often visit our granny who lives in Siberia. It takes us several days to get there. But I don't worry about it. I always take some interesting books with me. We can have meals or tea in our compartment or go to the dining-car. I like lying and looking through the window. The nature is fantastic in our country. It's pleasant to get off the train and walk a little. When we travel I always make new friends. When we come back home we begin to exchange e-mails or talk on the phone. I like to play board games with my parents. It's so exciting. There is nothing like travelling by train!

**Answer these questions and write a composition "Travelling by Train"**

1. Are you fond of traveling by train?
2. How often do you travel by train?
3. Where do you prefer to travel only by train? Why?
4. What is cheaper: travelling by plane or by train?
5. What do you usually do during your trip by train?
6. What things do you always take with you?
7. Where do you prefer to have meals?



8. Do you like lying and watching through the window?
9. Do you always get off during stops ?
10. Can you make friends during your trip ?
11. What board games do you play when you travel ?
12. Can you say that travelling by train is very exciting ?

**1. Установите, в каком из текстов (1-6) можно найти информацию, соответствующую разделам (A-F). Один тест лишний.**

- A. Development
- B. Station facilities
- C. Configurations of train station
- D. Superlatives
- E. Train station

1. This is a point of call for trains, allowing the loading or unloading of goods, or allowing passengers to board and alight. Early stations were usually built with both passenger and goods facilities. This dual-purpose is still common today, although in many cases, goods facilities are now restricted to major stations. Generally stations are sited next to a railway or railroad line, or form the terminus for a particular route. Usually platforms are present to allow passengers easy and safe access to trains.

2. The first train station resembled tram stops, with little in the way of buildings or facilities. Although the Stockton and Darlington Railway was the first railway, it only carried freight. So the first train stations in the modern sense were on the Liverpool and Manchester Railway, opened in 1830. Various forms of architecture have been used in the construction of railway stations, from those boasting grand and intricate almost baroque-style edifices, to more stark utilitarian or modern styles. Stations built more recently often have a similar feel to airports, with a cold and plain abstract style.

3. The world's busiest train station, in terms of daily passenger traffic, is Shinjuku Station in Tokyo, Japan. Ikebukuro Station, just minutes away, is the world's second-busiest. By train traffic, the world's busiest train station is Clapham Junction in London. The world's largest train station, in terms of floor area, is Nagoya Station in Nagoya, Japan.

4. A terminus is a station sited where a railway line ends or terminates. Thus, platforms can be reached without crossing tracks. Often a terminus is the final destination of a train, but not necessarily. When a train is required to travel onwards from a terminus, it must reverse out of the station to continue the trip.

5. Train stations usually include either ticket booths, or ticket machines. Ticket sales may also be combined with customer service desks, or convenience stores. All but small rural stations usually include some form of convenience store. Larger stations usually have fast-food or restaurant facilities. In some countries, such stations would also have a bar, or pub. Other station facilities include: toilets, left-luggage, departures and arrivals boards, luggage carts, waiting rooms, taxi rank and bus bays.

6. In addition to the basic configuration of a train station apart. The first is elevation. While most stations are at ground level, those in cities or urban areas are often elevated, or situated below ground, even if the station is not necessarily part of an underground metro system. The reason is usually to grade-separate road systems. Elevated stations are more common, not including metro stations.

Another unusual configuration is where the station serves railway lines at differing levels. This may be due to the stations situation at a point where two lines cross, or may be to provide separate station capacity for two types of service , e.g. intercity and suburban, or simply two different destinations.

## Практическое занятие 15. Проблемы во время путешествий и их решение.

№1. Посмотрите на картинки и заполните пропуски в предложениях предлогами, данными в рамке.

Norman drove

- 7) \_\_\_\_\_ the garage
- 8) \_\_\_\_\_ the road, and
- 9) \_\_\_\_\_ the bridge.

Then he drove

- 10) \_\_\_\_\_ the pub,
- 11) \_\_\_\_\_ the hill, and
- 12) \_\_\_\_\_ the hill.

Next he drove

- 13) \_\_\_\_\_ the river,
- 14) \_\_\_\_\_ the hedge, and
- 15) \_\_\_\_\_ the lake!

### Discuss the questions:

1. What kind of problems did you have when you were travelling? Tell us more about the most serious problem.
2. How many times have you got lost while travelling? What happened? If you get lost do you usually try to find out where you are by yourself or do you ask for help?
3. Has anyone promised to pick you up at the airport or railway station but hasn't done that?
4. Have you ever sat next to a very unpleasant passenger? What did you do?
5. Have you ever been injured when you were travelling?
6. Have you ever made a complaint at the hotel? What about? Was the problem solved?
7. Have you ever been to a really disgusting hotel? Did you stay or leave?

What problems might you have if you...

1. travel by car
2. travel by plane

3. travel by train
4. problems in the city
5. hike
6. stay in a hotel

Useful phrases: ● get a puncture ● miss the flight ● forget your passport ● get sunburnt ● bad service ● your wallet is stolen ● go to embassy ● be mugged ● get stuck in a traffic jam ● call an ambulance ● lose luggage ● lack of cleanliness ● tap is leaking ● cockroaches in the room ● feel motion sickness

### **Roleplay the dialogues:**

Example:

Person 1: My wallet is stolen. What should I do? / What advice can you give me if I don't want to have this problem in future?

Person 2: You should report to the local police. It's good idea to... You need to... If I were in your place, I'd... In my experience.... Be sure to...

List of problems:

1. My passport is stolen.
2. I have motion sickness on the plane.
3. It's only the first day of my beach holiday, but I have sunburn and sunstroke.
4. I have been bitten or stung by a jellyfish, spider, scorpion or snake.
5. I missed the last train back to my hotel.
6. My car breaks down in the middle of the Outback in Australia.
7. I lost my boarding pass between the check in desk and passport control.
8. I can't sleep on the plane because my neighbour has a loud walkman and has the reading light on.
9. I spent all my money in the casino last night.
10. I left something behind and have to get the hotel to send it on to me.

## Практическое занятие 16. Диалоги в аэропорту и на вокзале.

### **Задание 1. Прочитайте определение и напишите слово.**

1. a person who travels on public transport: p...ss...ng...r
2. the bags that you take with you when you travel: l...gg...g... or b...gg...g...
3. where you sit while using transport: s... ..t
4. different sections of a train: c...r/ c... rr...g...s
5. where people get on a train: pl...tf...rm
6. where you can ask questions about your journey: ...nf...rm...t... ..n d...sk

### **Задание 2. Заполните диалог словами, данными в рамке. Инсценируйте его.**

hand baggage      pack      passport      take off      card passport  
Not at all      check in      luggage

**At the check-in desk**

- A. Good morning, sir.  
B. Can I 7) ... here?  
A. Yes, you can. How much 8)... have you got, sir?  
B. I've just got a case to check in and a laptop for 9).... That's OK, isn't it?  
A. Of course. Did you 10)... your case yourself, sir?  
B. Yes, I did.  
A. Could I see your 11)..., please? Great, that's fine.  
B. The plane's going to 12)... late, isn't it?  
A. Yes, sir but it's only few minutes late. Here is your boarding 13).... Go through  
14)... control now. It goes from gate number twenty-one.  
B. All right. Thank you.  
A.15)..., sir.

**Задание 3. Дополните диалог фразами. Инсценируйте его.**

- Do I have to change?*  
*How much will that be?*  
*Single or return?*  
*What platform does it go from?*  
*What time does it get to Leeds?*

- 
- Boy: Two tickets to Leeds, please.  
Woman: 16) ... ?  
Boy: Oh, well, I want to come back on Saturday. 17) ... ?  
Woman: £28, please.  
Boy: 18) ... ?  
Woman: Yes, you do. Just once - at Peterborough.  
Boy: I'm going to get the 16.42 train. 19) ... ?  
Woman: At half past seven.  
Boy: OK, thanks. 20)... ?  
Woman: Sixteen. You have to go across the bridge.  
Boy: Thank you!

**Задание 4. Заполните пропуски подходящими словами в рамке**

flight attendant      passports      flight      gate      passport control  
non-smoking      customs      boarding cards      check-in      trolley

I was flying to London but I didn't know the right 21) ... desk. I asked a BA (British Airways) 22) ... who was passing and she told us. We waited in the queue with our cases on a

23) .... I noticed the man in front of us. He had no cases, only a small bag. When we got to the desk I showed our 24) ... and tickets. I asked for a 25) ... seat but the man at the desk said that there was no smoking on any flights these days. Then he gave us our 26) .... He said we were early and our 27) ... didn't have a 28) ... number yet. We went through 29) ... and showed our passports and boarding cards, and then I saw that man again, the man who had been in front of us at the check-in. He smiled at me. 'Will you take my bag through for me?' he asked. 'I'm just going to the toilet; I'll be back in a minute.' 'No,' I said. 'Sorry.' Later, after we had landed at our destination, I saw that the police had arrested the man at 30) .....

### Практическое занятие 17. Диалоги в незнакомом городе.

1. Прочитайте объявления и заполните диалоги, подходящей по смыслу информацией, выберите и инсценируйте диалог.

В тетради запишите номер и слово (число). Пример: 23) – Broadway.

<p><b>PETE'S BICYCLES</b></p> <p>Explore Norfolk by bicycle!</p> <p>Come and go as you please.</p> <p>£20 a day (children £15)</p> <p><b>Open:</b> from 8.00 in the morning to 8.00 at night</p> <p>Tel 02654 768036</p>	<p><b>BROADWAY GARDEN</b></p> <p>Come and enjoy our beautiful trees and flowers!</p> <p>Shop with plants, gifts, and books</p> <p>Café with sandwiches and drinks</p> <p><b>Location:</b> five miles from Cambridge on the A43</p> <p><b>Admission:</b> £6.25</p>
<p><b>CHESTER TOUR</b></p> <p>Guided tours of the city</p> <p><b>Price:</b> £8 adults, £5 children</p> <p>The bus leaves from the Tourist Information Centre at 10, 12, 2, and 4.</p> <p>The tour takes two hours.</p>	<p><b>CARTER'S GIFT SHOP</b></p> <p>Buy gifts for your friends and family.</p> <p>Delicious food, and lots more!</p> <p><b>Open:</b> Monday to Saturday 9 a.m. – 5 p.m.,</p>

	Sunday 10 a.m. – 4 p.m.  Hempstead Road, opposite the  museum
--	---

### Dialogue 1

- A: Excuse me. I'd like to visit a garden.  
 B: Well, you can go to 23) **Broadway** Garden.  
 A: Where is it?  
 B: It's 24) \_\_\_\_\_ miles from Cambridge.  
 A: How much is it to get in?  
 B: It's 25) \_\_\_\_\_ .  
 A: Can I buy gifts?  
 B: Yes, there's a 26) \_\_\_\_\_  
 A: And is there a restaurant?  
 B: No, but you can eat 27) \_\_\_\_\_ in the café.

### Dialogue 2

- A: Hello, can we have bicycles, please?  
 B: Yes, for two children and two adults?  
 A: Yes, that's right.  
 B: That's 28) \_\_\_\_\_ .  
 A: What time do you close?  
 B: At 29) \_\_\_\_\_ .

### Dialogue 3

- A: Excuse me. Where does the bus leave from?  
 B: It goes from 30) \_\_\_\_\_ .  
 A: How much is an adult ticket?  
 B: 31) \_\_\_\_\_ . It takes  
 32) \_\_\_\_\_ hours.  
 A: Thank you. It's eleven o'clock now. What time is the next 33) \_\_\_\_\_ ?  
 B: At 34) \_\_\_\_\_ .

### Задание

1. Напишите какие слова, имеющие отношения к транспорту, здесь зашифрованы.

- |                    |          |
|--------------------|----------|
| 1) raticff         | 4) ixta  |
| 2) alvert          | 5) pihs  |
| 3) tainost yriwala | 6) veird |

2. Заполните пропуски в диалогах словами в рамках, инсценируйте их

bus stop      get off      take      on your right      get to  
 straight

### Dialogue 1

- A: Excuse me, please? How can I 7) \_\_\_\_\_ the railway station?  
 B: Well, go 8) \_\_\_\_\_ to that building. There you'll see the 9) \_\_\_\_\_ .  
 10) \_\_\_\_\_ bus number 10 and 11) \_\_\_\_\_ near the theater. 12) \_\_\_\_\_ there'll  
 be the railway station.

past            along            With pleasure!            turn left  
crossing            next to

## Dialogue 2

A: Excuse me? 13) \_\_\_\_\_

B: Certainly. 14) \_\_\_\_\_

A: Where's the nearest chemist's?

B: Go 15) \_\_\_\_\_ the street, 16) \_\_\_\_\_ the bank till the 17) \_\_\_\_\_.

18) \_\_\_\_\_ and 19) \_\_\_\_\_ the restaurant you'll see the chemist's.

## 2. Прочитайте диалог и ответьте на вопросы.

### WASHINGTON CABS

In many American cities taxi-cabs have meters which show how much a passenger has to pay. In Washington, however, the taxis do not have meters. The city is divided into zones, and the fare depends on the number of zones a passenger rides through. Yesterday Nick and Pete took a taxi to Georgetown. It was Nick's first ride in a Washington taxi, and he noticed the absence of a meter.

Nick: This taxi has no meter.

Pete: No, in the District fares are taken by the zones.

Nick: What is the fare per zone?

Pete: Well, for the first zone it's sixty cents. Even if you ride only for a half block.

Nick: I see. It is sixty cents just to get in.

Pete: Right. Then for each additional zone you pay thirty cents.

Nick: Let's see, I get in the cab in zone one; I get out in zone two. How much is the fare?

Pete: Ninety cents – sixty cents for the first zone and thirty for the second.

### Questions

- 1) How can we learn the fare for a trip in most American cities?
- 2) Why does a Washington taxi differ?
- 3) What does the fare depend on in taxis in Washington?
- 4) Where did Nick and Pete go in a taxi?
- 5) How much does the first zone cost in Washington taxis?
- 6) How much did they have to pay?

## 3. Раскройте скобки и поставьте глаголы в Present Perfect Tense. Напишите в тетради номер ответа и глаголы:

- 1) Have you lost    2) haven't    3) has just sat

Пример: A: I can't read the board.

B: 1) *Have you lost* (you/lose) your glasses?

A: No, 2) *I haven't* (No). Jack 3) *has just sat* (just/sit) on them.

### Dialogue 1

A: Let's go for a walk.

B: 26) \_\_\_\_\_ (it/stop) raining?

A: 27) \_\_\_\_\_ (No). But I 28) \_\_\_\_\_ (just/find) my umbrella. 29) \_\_\_\_\_ (you/take) yours?

## Dialogue 2

A: They 30) \_\_\_\_\_ (just/repair) my mobile phone.

B: 31) \_\_\_\_\_ (you/try) it?

A: 32) \_\_\_\_\_ (Yes).

B: 33) \_\_\_\_\_ (you/call) Jack yet?

A: No, I haven't. I 34) \_\_\_\_\_ (send) him a message.

## Практическое занятие 18. Осмотр достопримечательностей.

### Read the text

#### Great Britain

The United Kingdom of Great Britain and Northern Ireland is situated off the Northwest coast of Europe. The UK consists of four parts. They are: England, Scotland, Wales and Northern Ireland. The UK lies on the British Isles. The two main islands are Great Britain and Ireland. They are separated from the continent by the English Channel and the Strait of Dover. The west coast of the country is washed by the Atlantic Ocean and the Irish Sea, the east coast is washed by the North Sea. The population of the United Kingdom of Great Britain and Northern Ireland is nearly 60 million.

Geographically Great Britain is divided into Lowland Britain and Highland Britain. Lowland Britain comprises Southern and Eastern Britain. Highland Britain includes Scotland, Wales, the Pennines and the Lake District. The highest mountain, Ben Nevis, is in Scotland. The flora of the British Isles is much varied and the fauna is similar to that of the north-west of Europe.

Britain is not very rich in natural industrial resources. The main coal areas are the South Wales fields, the Lowlands of Scotland, the Yorkshire field and others. The deposits of iron ore are in the east of England and in the Middle-England plain.

The climate of Great Britain is mild. The Atlantic Ocean and the warm waters of Gulf Stream influence the weather of the British Isles. Summers are cool and rainy. There is a lot of rain and fog in autumn and in winter.

There are a lot of rivers in Great Britain. The Severn is the longest river; the Thames is the most important one.

The United Kingdom is one of the world's most industrialized countries. Big cities and towns such as London, Glasgow, Manchester, Liverpool and others have enterprises of nearly all branches of industry, old and new.

The biggest centers of iron and steel industry are situated in the neighbourhood of coal basins. They are Newcastle, Cardiff, Glasgow and Sheffield. Steam engines and electric motors, machine tools, derricks, textile machinery, locomotives and automobiles are produced at the machine-building plants of Birmingham, Sheffield and London. The shipbuilding industry is of great importance for Britain. Many countries place orders for new ships with the British shipyards in Glasgow, Belfast and Newcastle. The most important branches of the textile industry are woolen and cotton industries. British woolen stuffs are widely known for their high quality. The main center of the cotton industry is Manchester. Britain imports cotton from America and other countries through the port of Liverpool.

The capital of the country is London. English is the official language.

Great Britain is a constitutional monarchy. The powers of the British Queen are limited by Parliament. The British Parliament consists of the Sovereign, the House of Lords



and the House of Commons. The main political parties of Great Britain are the Conservative and Labour Parties. The United Kingdom of Great Britain and Northern Ireland has always played an important role in world politics.

Notes:

English Channel [ˈɪŋɡlɪtʃænl]	- Английский канал (принятое в Великобритании название пролива Ла- Манш)
Highland Britain [ˈhaɪləndˈbrɪtn]	- гористая часть Великобритании
Lowland Britain [ˈləʊləndˈbrɪtn]	- низменная часть Великобритании
Lowlands of Scotland	- Шотландская низменность
Lake District [ˈleɪkˈdɪstrɪkt]	- Озерный край, Озерный округ (живописный район рек и озер на северо- западе Англии)
The Pennines [ˈpenaɪnz]	- Пеннинские горы
Strait of Dover [ˈstreɪtəvˈdəʊvə]	- Па-де-Кале (букв. Дуврский пролив)

Задание 1. Найдите соответствия (перевод). В тетрадах запишите номер и букву, выбранного варианта.

a coast	делить
to consist of smth.	соседство
to lie	палата
to divide	включать в себя
to include	монарх
to vary	власть
mild	побережье
to influence	изменяться

neighbourhood	качество
to produce	располагаться
quality	оказывать влияние
power	остров
the House	производить, выпускать
a sovereign	состоять из чего-либо
an island	мягкий

Задание 2. Заполните пропуски в предложениях словами из текста. Напишите номер предложения и слово.

The UK is \_\_\_\_ off the Northwest coast of Europe.

Great Britain and Northern Ireland are \_\_\_\_ from the continent by the English Channel and the Strait of Dover.

The east coast of the country is \_\_\_\_ by the North Sea.

Lowland Britain \_\_\_\_ Southern and Eastern Britain.

The fauna of British Isles is \_\_\_\_ to that of the north-west of Europe.

The \_\_\_\_ of iron ore are in the east of England and in the Middle-England plain.

The summers are \_\_\_\_ and rainy.

Big cities and towns have \_\_\_\_ of nearly all \_\_\_\_ of industry.

The ship-building industry is \_\_\_\_ for Britain.

A lot of countries \_\_\_\_ for new ships with British shipyards.

The most important \_\_\_\_ of the textile industry are woolen and cotton industries.

The UK has always \_\_\_\_ an important \_\_\_\_ in world politics.

## Практическое занятие 19. Достопримечательности Санкт-Петербурга.

**Answer the following questions and tell us about St. Petersburg.**

1. Have you ever been to St. Petersburg?
2. Is St. Petersburg your hometown?
3. When was it founded?
4. Who is the founder of St. Petersburg?
5. What did St. Petersburg begin with?
6. When did it become the capital of Russia? What Tsar did it?
7. What is St. Petersburg famous for?
8. What is the historical centre of St. Petersburg?
9. Have you ever been to the Hermitage?(the Russian Museum?)
10. What other places of interest in St. Petersburg do you know?
11. Why is St. Petersburg called the Northern Venice?
12. How many times has the city been renamed and why?
13. Did the city suffer a great deal during the Great Patriotic War?
14. Why is St. Petersburg called the cultural capital of Russia?

15. St. Petersburg is one of the world's scientific and educational centres, isn't it? Why?
16. Is the city industrial centre of our country?
17. What is its population?
18. What are the most popular sports facilities in St. Petersburg?
19. In what season is the city especially beautiful?
20. What is your favourite place in St. Petersburg?

### **Read the text**

#### *Saint Petersburg*

St. Petersburg is the second largest city in Russia and one of the most beautiful cities in the world. It was founded in 1703 by Peter the Great as the "Window on Europe." St. Petersburg was the capital of Russia from 1712 till 1918.

The city was built on the swampy land at the mouth of the River Neva. Prominent European and Russian architects worked here. The new capital grew rapidly in wealth and beauty.

When World War I began in 1914, the German-sounding name St. Petersburg was changed to Petrograd. After the October Revolution the city was renamed in honour of Lenin. In 1991 the old name of St. Petersburg was returned to the city.

During the Great Patriotic War the city suffered a great deal. The German armies laid siege to it in 1941, and for the next two years and a half the city was cut off from the rest of the country. No food could be brought in, and people died of starvation. Daily shelling and air raids destroyed parts of the city. Thousands of people were killed. Rebuilding took years.

Now St. Petersburg is an industrial, cultural and scientific centre. There are over 80 museums, more than 20 theatres, a lot of exhibitions, clubs, universities, colleges, schools and parks. The Alexandrinski Drama Theatre, the Bolshoi Drama Theatre, the Mariinsky Theatre of Opera and Ballet are pearls of the Russian art.

In St. Petersburg there are a lot of parks and gardens where citizens spend their free time. The Summer Garden is the oldest and most fascinating park. Rare trees, bushes and flowers grow there. Beautiful marble statues made by Italian sculptors and a famous cast iron grille decorate the Summer Garden. There is a bronze monument to the prominent Russian writer of fables Ivan Krylov (by sculptor Klodt) in the Summer Garden.

St. Petersburg is famous for its magnificent architectural ensembles of the 18th and 19th centuries. The city began with the Peter and Paul Fortress built to protect the Neva banks from Swedish invasion. Later Domenico Trezzini, the famous Swiss architect, reconstructed the fortress. It became a prison. Now it is a museum. Trezzini erected the Peter and Paul Cathedral here, and Russian tsars were buried in it.

The most famous square in the city is the Palace Square with its magnificent ensemble. Here one can see the Winter Palace built by Rastrelli. Till the revolution it was the residence of the Russian csars. Now the Winter Palace and four other buildings are occupied by the Hermitage, one of the oldest art museums in Russia. There one can see masterpieces of outstanding artists: Leonardo da Vinci, Raphael, Rembrandt, Velazquez and other unique works of art.

The Russian Museum is located in the Mikhailovsky Palace, designed by Rossi. Marvellous paintings by the famous Russian artists: Tropinin, Repin, Bryullov, Fedotov, Surikov, Serov; the works of sculptors: Rastrelli, Shubin, Antokolsky are exhibited here. The streets and squares in St. Petersburg are very beautiful. Nevsky Prospect is the main street of the city, where there are amazing buildings, shops, hotels and the remarkable Kazan Cathedral (by Voronikhin) with a colonnade and monuments to M. Kutuzov and Barclay de Tolly. Here in the prospect one can see the magnificent building of the

Admiralty (by Zakharov) and the ensemble of the Alexander Nevsky Lavra. Famous Russian writers, painters, composers and actors were buried in the Lavra. Majestic palaces, cathedrals, churches and other buildings, built by famous architects, such as: palaces of Stroganov, Menshikov, Anichkov, and St. Isaac's Cathedral, erected by Montferrand, decorate St. Petersburg. The city is often called the Venice of the North because there are 65 rivers and canals with artistically decorated cast iron bridges. One of the most beautiful is the Anichkov Bridge. Citizens and tourists enjoy visiting the suburbs of St Petersburg: Petergof, Pushkin, Pavlovsk with their wonderful palaces, parks and fountains. St. Petersburg inspired many of our great poets, writers, painters, sculptors, composers and actors. Much of the life and work of Pushkin, Dostoevsky, Tchaikovsky, Repin and Kramskoi was connected with the city.

## Практическое занятие 20. Экскурсия в мой родной город.

### №1. Answer the questions

- Do you like your town?
- Are there any parks in our town?
- Are there any theatres in our town?
- Are there any school in our town?

### № 2. Ask and answer the questions about your city (town)

1. What is there in the city?  
There is a hospital in the city.  
There is a pet shop in the city.
2. Where is the shop?

The hospital	is	near the...
The museum		behind the...
The cinema		on the left of...
The zoo		on the right of...
The river		in front of...
The supermarket		on the corner of...
		in the middle of...

### Make and roleplay the dialogs:

(Example)

- P1: N, excuse me, is there a shop in your town?
- P2: Yes, there is a shop in my town.
- P1: Where is the shop?
- P2: The shop is near the river.

### Read and roleplay the dialogs:

1

Mark : Excuse me. Do you know how to get to the mall?

Betty : Sure, I used to work there. Go straight for about a mile, then turn left at the light. The mall will be on the right.

Mark : Do you know the address?

Betty : Yes, the address is 541 Main street.

Mark : Can you write it down for me please?

Betty : No problem.

Mark : Is it faster if I take Highland avenue?

Betty : No, that way is longer. There are more stop lights on that street.

Mark : I think you're right. Thank you.

2

Paul : Excuse me, I'm looking for the Holiday Inn. Do you know where it is?

Nancy : Sure. It's down this street on the left.

Paul : Is it far from here?

Nancy : No, it's not far.

Paul : How far is it?

Nancy : About a mile and a half.

Paul : How long does it take to get there?

Nancy : 5 minutes or so.

Paul : Is it close to the subway station?

Nancy : Yes, it's very close. The subway station is next to the hotel. You can walk there.

Paul : Thanks a lot.

3

Amy : Hi Michael.

Michael : Hi Amy. What's up?

Amy : I'm looking for the airport. Can you tell me how to get there?

Michael : No, sorry. I don't know.

Amy : I think I can take the subway to the airport. Do you know where the subway is?

Michael : Sure, it's over there.

Amy : Where? I don't see it.

Michael : Across the street.

Amy : Oh, I see it now. Thanks.

Michael : No problem.

Amy : Do you know if there's a restroom around here?

Michael : Yes, there's one here. It's in the store.

Amy : Thank you.

Michael : Bye.

Amy : Bye bye.

### **My home town**

#### **Plan:**

1. Where do you live?
2. What do you know about your town?
3. What is the history of your town?
4. What parts is your town divided in?
5. What is there in the city center?
6. Do you like your town?

#### **Read the text.**

There are many beautiful cities and towns in the world. I would like to visit some of them, to see with my own eyes what I have read or heard about. But there is no place like home. I love my native city. I was born here and live with my parents. It's not the capital, but it is a wonderful place to live.

My city is old and modern at the same time. It is old because it was founded in the 11th century. At that time its streets were narrow, dark and dirty. Now my city looks modern because of its architecture. Almost all the buildings were built after the war. The streets and avenues are wide and clean.

I live in the main street. It is the widest street in the city. A lot of cars, buses and trolley-buses run fast along it. If you want to see the places of interest in our city, you can walk along the main street. It leads to the main square. It will be a short trip, but you can see a lot: a cinema and a concert hall, an art gallery and museums, a stadium, a zoo and a large park.

Our art gallery is next to the main post office. Opposite the post office there is a modern hotel. If you turn to the left, you can see a theatre. And in front of the theatre there is a museum of history and culture. Walk two blocks and you'll come to a monument to our famous writer and a fountain in the park. If you want to visit our zoo, take a bus and get off on the third bus stop. Not far from the traffic lights you will see the entrance to the zoo. Near it there is a circus. Children and tourists can't but visit it. They admire funny clowns, tamed animals, miracles and magic. There are only some churches in our city. Every evening we can hear the sound of the bells.

Our city stands on the river. Parks, lanes, bridges across the river, small water falls and man-made islands add much to the beauty of the city.

Just come and see everything with your own eyes. It is better to see than to hear.

## Практическое занятие 21. Обобщение лексического материала.

**1. Установите, в каком из текстов (1-6) можно найти информацию, соответствующую разделам (A-F). Один тест лишний.**

A. Development

B. Station facilities

C. Configurations of train station

D. Superlatives

E. Train station

1. This is a point of call for trains, allowing the loading or unloading of goods, or allowing passengers to board and alight. Early stations were usually built with both passenger and goods facilities. This dual-purpose is still common today, although in many cases, goods facilities are now restricted to major stations. Generally stations are sited next to a railway or railroad line, or form the terminus for a particular route. Usually platforms are present to allow passengers easily and safely access trains.

2. The first train station resembled tram stops, with little in the way of buildings or facilities. Although the Stockton and Darlington Railway was the first railway, it only carried freight. So the first train stations in the modern sense were on the Liverpool and Manchester Railway, opened in 1830. Various forms of architecture have been used in the construction of railway stations, from those boasting grand and intricate almost baroque-style edifices, to more stark utilitarian or modern styles. Stations built more recently often have a similar feel to airports, with a cold and plain abstract style.

3. The world's busiest train station, in terms of daily passenger traffic, is Shinjuku Station in Tokyo, Japan. Ikebukuro Station, just minutes away, is the world's second-busiest. By train traffic, the world's busiest train station is Clapham Junction in London. The world's largest train station, in terms of floor area, is Nagoya Station in Nagoya, Japan.
  4. A terminus is a station sited where a railway line ends or terminates. Thus, platforms can be reached without crossing tracks. Often a terminus is the final destination of a train, but not necessarily. When a train is required to travel onwards from a terminus, it must reverse out of the station to continue the trip.
  5. Train stations usually include either ticket booths, or ticket machines. Ticket sales may also be combined with customer service desks, or convenience stores. All but small rural stations usually include some form of convenience store. Larger stations usually have fast-food or restaurant facilities. In some countries, such stations would also have a bar, or pub. Other station facilities include: toilets, left-luggage, departures and arrivals boards, luggage carts, waiting rooms, taxi rank and bus bays.
  6. In addition to the basic configuration of a train station apart. The first is elevation. While most stations are at ground level, those in cities or urban areas are often elevated, or situated below ground, even if the station is not necessarily part of an underground metro system. The reason is usually to grade-separate road systems. Elevated stations are more common, not including metro stations.
- Another unusual configuration is where the station serves railway lines at differing levels. This may be due to the stations situation at a point where two lines cross, or may be to provide separate station capacity for two types of service, e.g. intercity and suburban, or simply two different destinations.

## Практическое занятие 22. Обобщение грамматического материала.

### Task 1. Put the verbs in brackets into the Present Perfect Continuous Tense

1. ... Jenny ... (to wait) for her flight in the airport since twelve o'clock? — No, she .... She ... (to wait) for her flight for forty minutes now.
2. Can I talk with you? — Sorry, I'm busy. I ... (to look) for one important paper for more than twenty minutes now and can't find it.
3. Is Ed at home? — No, he is in the gym. He ... (to train) since five o'clock.
4. ... your mother ... (to work) as a manager for ten years? — No, she .... She ... (to work) as a manager for eighteen years.
5. Is Philip fixing the washing-machine? — Yes, he ... (to fix) it since nine o'clock.
6. Alison and Cindy ... (not to paint) the walls in the room for two hours. They ... (to work) since morning.
7. The Petersons ... (to build) their house for three years now.
8. Is mother in the kitchen? — Yes, she ... (to cook) since four o'clock.
9. You look tired! — Well, I ... (to gather) strawberries for more than two hours.
10. Where is Ben? — He is in his room. He ... (to listen) to music since afternoon

### Task 2. Put the verbs in brackets into the Present Perfect Continuous Tense

#### Задание 8. Поставьте глаголы в скобках в правильную форму the Present Perfect Continuous Tense

1. Helen ... (to wash) the dishes for fifteen minutes.

2. My classmates ... (to write) a dictation since the beginning of the lesson.
3. Sam ... (to drive) a car for five hours now.
4. I ... (to look) for information on the subject since last Friday.
5. Molly ... (to paint) this picture for three days now.
6. The tourists ... (to do) the sightseeing since nine o'clock.
7. You ... (to work) as a computer programmer for more than fifteen years.
8. The wind ... (to blow) since yesterday.
9. My grandfather ... (to collect) coins since he was a boy.
10. Andy and Den ... (to discuss) the plans for their winter holidays for two hours now.

Complete the sentences with a suitable modal verb. Use **must, don't have to, might, should, must have, mustn't, can't have and shouldn't**.

1. You \_\_\_\_\_ drive on the pavement. It's illegal.
2. You \_\_\_\_\_ say that. It's not nice.
3. I \_\_\_\_\_ go to work tomorrow because it's a public holiday.
4. I \_\_\_\_\_ buy this CD, but I'm not sure.
5. He's not here. He \_\_\_\_\_ gone out.
6. She didn't study enough. She \_\_\_\_\_ passed her exam.
7. You \_\_\_\_\_ eat more vegetables. They're good for you.
8. You \_\_\_\_\_ be 18 before you can buy alcohol.

### Choose the correct alternative

1. You *must / should / shouldn't* be 18 before you can drive in Spain.
  1. You *don't have to / mustn't / shouldn't* go to bed so late. It's not good for you.
  2. You *don't have to / mustn't / shouldn't* wear a school uniform in most Spanish state schools.
  3. You *must / mustn't / needn't* come. I can do it without you.
  4. You *don't have to / must / mustn't* copy during exams.
  5. You *don't have to / mustn't / shouldn't* be very tall to play football.
  6. You *must / mustn't / needn't* be a good writer to win the Pulitzer Prize.

## 5 семестр

### Практическое занятие 1. Компьютеры в повседневной жизни

1. **Цель работы:** изучить новую лексику по теме, повторить грамматические конструкции Present Simple и Present Continuous
2. **Задачи работы:** научиться использовать новые лексические единицы в речи и понимать их в контексте, активизация грамматических конструкций в речи
3. **Подготовка к работе:** повторение теоретического материала Present Simple и Present Continuous
4. **Задание 1:** прочитать текст и выполнить послетекстовые задания.

#### COMPUTERS IN EVERYDAY LIFE

Computer can be used at home in a variety of ways. One of the most popular ways ordinary people use it is home entertainment. What can be better after a hard day at work or university than watching a new episode of an all-liked serial? You can also get your naughty kids **engaged in**



watching exciting cartoons while you are doing your everyday **household chores**. You can listen to your favourite songs on YouTube, find the lyrics and sing along!

Computer or video games have become extremely popular today. Due to the Covid-19 pandemic, gaming has become a means of **escapism** and time filling for many people. According to the Global Games Market Report, in October 2020 there were 2.7 billion gamers in the world that spent an amazing \$174.9 billion on games (with “Animal Crossing: New Horizons” and “Call of Duty: Modern Warfare” being the top two best-selling video games), and the market is reported to **surpass** \$200 billion by 2023. Video gamers spend an average of six hours 20 minutes each week playing games. Nearly one-third (32 percent) play more than seven hours each week, with 17 percent playing more than 12 hours a week.

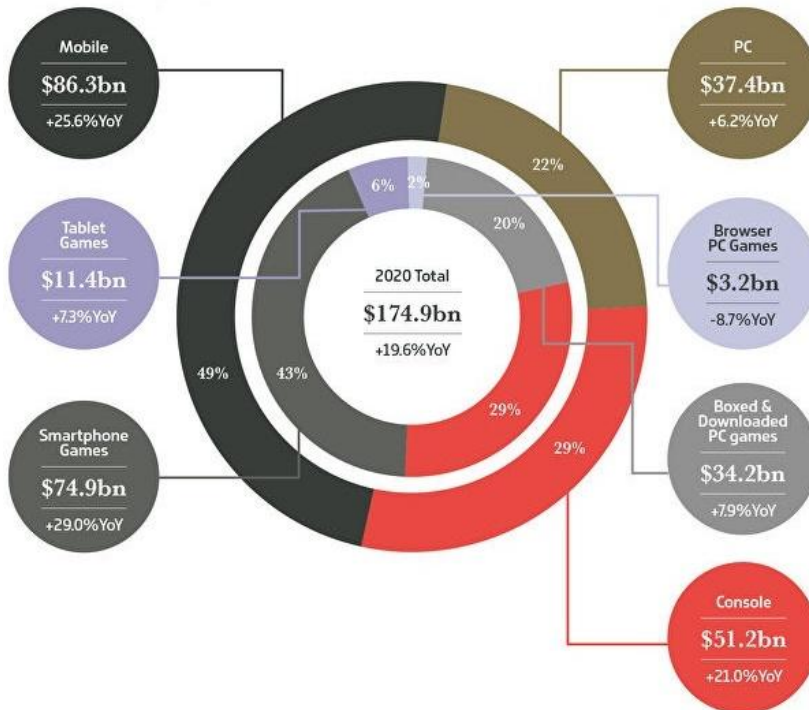

*2020 global games market per device and segment with year-on-year growth rates (from Newzoo 2020 Global Games Market Report)*

Another important use of computer at home is social networking. There are really few people today who don't have a profile on a social networking website. People post **updates** about recent events in their lives, publish their opinions on hot issues, upload pictures, and share their favourite music or links to some external sources. Social networks help people to make new friends or keep in touch despite the distances. Recent surveys show that the average social media usage of internet users worldwide **amounts to** 145 minutes per day.

Chatting and **instant messaging** seem to be replacing **conventional** phone calls nowadays. Over 560 billion texts are sent every month worldwide, not including app-to-app messaging, and WhatsApp and Facebook Messenger combine for more than 60 billion messages sent every day! Instant messages appear to be really convenient: the **recipient** doesn't have to be online when you text him or her. E-mailing remains a necessity for work communication. However, it is hardly ever used by young people, who still prefer various messengers even at work.

The Internet as a source of information can have a lot of practical everyday uses. We can learn about traffic jams or road accidents before going to work or read the weather forecast when we go on holiday. We can go to **recruitment agencies'** websites to search for a new job. School-leavers can find out about the process of admission to university and the requirements for applicants.

Commuter trains timetable, opening hours of shops and museums, places of interest and **current** events in town – whatever might interest us is here on the Internet.

Computer is an invaluable helper for students. When they need some information for a presentation or report, they can look it up on the Web. Students often use various educational websites to read articles or watch **tutorials**.

Online shopping is real deal for a busy modern person. Everything from new cupboards for your kitchen or trendy footgear to pizza for dinner is available in one click. Not only does it save your time, but, surprisingly, the goods are often cheaper online!

The last but not least example of home use of computer is managing the home budget. Gone are the days of cash in a pay packet and queues to pay bills! Online banking allows for paying bills and saving **receipts**, or **statements**, on your computer, special applications let you see how much money you spend every month and hence sort out your finances.

**Translate into English using the words in bold from the text. Change the form of the word if necessary:**

актуальная (насушная) проблема, отправить мгновенное сообщение, отвлечься от повседневности, сохранить квитанцию (оплаченный чек), публиковать регулярные обновления, интерактивное практическое занятие, адрес получателя, делать работу по дому, общепринятые методы, участвовать в дискуссии, составлять всего 2-3 процента, превзойти все ожидания, обратиться в агентство по подбору персонала (связаться с агентством по подбору персонала)

**Задание 2:** выполнить грамматические упражнения.

**1) Open the brackets using the correct form of Present Continuous verbs, affirmative, interrogative or negative. Match the verb forms a-h in the sentences to the correct use 1-6.**

1. Teleworking a) \_\_\_\_\_ (become) quite common today.
2. – What b) \_\_\_\_\_ you \_\_\_\_\_ (do) tonight? We could go out for dinner.  
– Sorry, I can't! I c) \_\_\_\_\_ (make) that important presentation in the morning.
3. We e) \_\_\_\_\_ (have) an English class now.
4. Jake d) \_\_\_\_\_ (not go) on holiday. The boss said he has to do a new project.
5. Paul f) \_\_\_\_\_ (not work) from home this week – he is at a conference in Canada.
6. “Why g) \_\_\_\_\_ the secretary \_\_\_\_\_ (be) so nice to me these days?” the boss thought. “Does she want a pay rise?”
7. – Can you tell me what the Wi-Fi password is?  
– Typically! You h) \_\_\_\_\_ always \_\_\_\_\_ (forget) the password! Okay, it's 123450.
8. Julia i) \_\_\_\_\_ (study) hard these days because she wants to get good grades in the exams.

- 1) a demonstration of unusual behavior
- 2) a trend
- 3) a frequent action emphasized in a hyperbolic way
- 4) a temporary action

- 5) a planned future action, an arrangement
- 6) an action happening at the time of speaking

**2) Open the brackets using Present Simple or Present Continuous forms of the verbs in each pair of sentences.**

- 1. Liza \_\_\_\_\_ on the phone with her friend. She \_\_\_\_\_ with her very often. (talk)
- 2. People often \_\_\_\_\_ food or clothes on the internet. More and more people \_\_\_\_\_ things online today. (buy)
- 3. a) Meg \_\_\_\_\_ so irritable recently. She might be having some family problems.  
b) You must meet my sister Annie! She \_\_\_\_\_ a nice person. (be)
- 4. Mark's job involves a lot of business trips, so he \_\_\_\_\_ quite frequently. Tomorrow he \_\_\_\_\_ to Germany. (fly)
- 5. We \_\_\_\_\_ at Hilton now. We always \_\_\_\_\_ in the most luxurious hotels. (stay)
- 6. Peter \_\_\_\_\_ no mistakes in the tests, but Chris \_\_\_\_\_ always \_\_\_\_\_ a load! (make)
- 7. Normally I \_\_\_\_\_ from 9 till 5, but this week I \_\_\_\_\_ long hours to meet the deadline. (work)
- 8. Laura \_\_\_\_\_ (think) of leaving her job. She \_\_\_\_\_ she needs a career change. (think)

**5. Порядок выполнения работы:**

- 1) изучение лексики, чтение текста, выполнение послетекстовых заданий;
- 2) повторение грамматического материала, выполнение упражнений

**6. Содержание отчета:**

словарный диктант, контроль понимания прочитанного, продуктивная речь по теме с применением новых ЛЕ и изученных грамматических конструкций

## Практическое занятие 2. Жизнь в цифровую эпоху

1. **Цель работы:** изучить новую лексику по теме, повторить грамматические конструкции Past Simple
2. **Задачи работы:** научиться использовать новые лексические единицы в речи и понимать их в контексте, использовать Past Simple в письменной и устной речи
3. **Подготовка к работе:** повторение теоретического материала Past Simple
4. **Задание 1:** прочитать текст и выполнить послетекстовые задания.

### DIGITAL TECHNOLOGY IN OUR LIFE

During the 20<sup>th</sup> century and in its second half in particular, the humanity **witnessed** an amazing breakthrough in technology. The expansion of cars, aircraft advance, splitting of the atom (nuclear fission), and outer space exploration gave a start to a new era when the world we live in started to change **drastically**. However, the most important developments took place in the area of human communication and the availability of information **due to** the invention of computers, mobile technology and the Internet.

Over the past decades, technology has **revolutionized** our world and daily lives. Computers have changed the ways we speak, act, learn, and interact with each other. They have changed the way we do quite a number of day-to-day activities such as working, shopping and searching for information. Now that computers are **proliferating** in many areas and networking enables people to access and share data easily, many people today telecommute or *telework* – that is, they stay in touch with their office while working from home. The Internet *telecommunications* provide videoconferencing, allowing colleagues to hold meetings without leaving their office. Co-workers can send e-mails to each other, fill in *spreadsheets* online and have access to online databases.

Special software created for the medical sphere, such as medical diagnosis *expert systems*, can help doctors to **establish** a diagnosis, suggest further examination or tests, and prescribe **appropriate** drugs. Using proper tools, medical experts can give professional advice to the staff of a hospital situated in any remote location. The disabled have also **benefited** from computers, which help them to communicate with others more effectively. Medical records and personal data of patients can be stored in computer databases.

Our shopping habits are changing. Online shopping is becoming increasingly popular today. We can order food, rent an apartment, buy clothes, book a hotel or make a flight reservation using the Internet. Online banking allows us to pay bills or transfer money without going to a *brick-and-mortar* bank.

Another notable development has **occurred** in the learning process. *Multimedia* systems, which combine text with sound, video, animation and graphics, **enhance** the interaction between the user and the machine and can make information more understandable and appealing to students. This combination of education and entertainment is called ‘edutainment’. Teachers can create online courses and deliver lectures online. People can join “open universities” and get certificates in various fields of expertise straight from home. Students can rely upon **multiple** web-based resources instead of going to the library.

Digital technologies have even **affected** the way parents are raising children. Recent research has shown that early learning by experience and imitation from family and caregivers gave way to increased use of digital device-based learning, which to a large extent replaced interpersonal

communication.

The entertainment industry has also changed. Home entertainment, e.g. digital television and video games, has begun to take up a lot of time. Instead of going to the cinema or an amusement park people often prefer to engage themselves in a computer game or watching a film on the web.

Finally, it is social interaction that has been affected most significantly by digital technologies. People started to choose digital communication rather than face-to-face conversation. They often choose texting or conversation on *social media* rather than coming round to a friend's place. Although the results of this phenomenon are to be studied yet, scientists claim that it has had a negative impact on so called '*soft skills*', namely, the ability to deal with people in physical reality. On the other hand, digital communication has the power of erasing boundaries between people of different nationalities and societies. As Angela Ahrendts, senior vice president of Apple, said, "I grew up in a physical world, and I speak English. The next generation is growing up in a digital world, and they speak social."

**Match the terms in Table A (in the text they are in *italics*) with the definitions in Table B.**

Table A

a	multimedia
b	telecommunications
c	expert system
d	brick-and-mortar
e	soft skills
f	spreadsheet
g	teleworking
h	social media

Table B

1	Non-technical skills related to interaction with people, solving problems and managing work.
2	Physically present in a building or other structure.
3	A form of communication that combines different content forms such as text, audio, images, animations or video into a single presentation.
4	Virtual communities or networks for creating and sharing information and ideas.
5	A paper or electronic file made of rows and columns to arrange data efficiently.
6	Working from home via the internet, e-mail or telephone.
7	The transmission of information by various types of technologies over wire, radio, optical or other electromagnetic system.
8	A computer application that emulates the decision-making ability of a human specialist.

**Translate into English using the words in bold:**

оказывать влияние на социальную среду, различаться кардинальным образом, распространяться по всему миру, установить правила игры, многочисленные сетевые ресурсы, пользоваться компьютером с выгодой для себя, применять подходящие инструменты, появляться в разных сферах, быть очевидцем технического прогресса, из-за распространения социальных сетей, в корне изменить современную жизнь, улучшать качество жизни

**Задание 2:** выполнить грамматические упражнения.

**1) Add -ed to the verbs and put them in the correct column according to pronunciation:**

add, bake, save, count, hope, play, laugh, invite, live, cry, reach, decide

[t]	[d]	[ɪd]
-----	-----	------

**2) Complete the text with the Past Simple form of the verbs in the box.**

get	spend	conclude	stimulate	compare	look	find	play
-----	-------	----------	-----------	---------	------	------	------

**VIDEO GAMES**

Twenty years ago, studies a) \_\_\_\_\_ that players of video games were very intelligent and motivated people. They b) \_\_\_\_\_ good results at school and at work. In those days, video games were quite simple, so what about the more complex games of today?

Many children start to play video games at seven. For most of them this is not a problem, but some of them become addicts. A recent study of children aged 13 and 14 c) \_\_\_\_\_ that almost a third played video games daily. Seven per cent d) \_\_\_\_\_ at least 30 hours playing every week. Addiction to games can lead to other problems such as stealing money to buy new games, failing to do homework or not going to school.

In another study, scientists at Japan's Tohoku University e) \_\_\_\_\_ at the brain activity of hundreds of students as they f) \_\_\_\_\_ a Nintendo game. They g) \_\_\_\_\_ this with the brain activity of other students doing mathematics. The result was surprising. The computer game only h) \_\_\_\_\_ those parts of the brain related to vision and movement, but not parts of the brain which are important for behaviour, memory, and learning.

**5. Порядок выполнения работы:**

- 1) изучение лексики, чтение текста, выполнение послетекстовых заданий;
- 2) повторение грамматического материала, выполнение упражнений

**6. Содержание отчета:**

словарный диктант, контроль понимания прочитанного, продуктивная речь по теме с применением новых ЛЕ и изученных грамматических конструкций

**Практическое занятие 3. Пользователи компьютеров**

**1. Цель работы:** изучить новую лексику по теме, повторить понятие исчисляемых и неисчисляемых существительных, артикли

**2. Задачи работы:** научиться использовать новые лексические единицы в речи и понимать их в контексте, правильно использовать артикли с существительными

**3. Подготовка к работе:** повторение теоретического материала «Артикли»

**4. Задание 1:** прочитать текст и выполнить послетекстовые задания.

**COMPUTERS IN DIFFERENT SPHERES OF LIFE**

Why is the use of a computer **essential** in daily life? You can make sure about the importance of computers by observing a revolution in offline and online business, education, industry, trade, communication, entertainment, science and banking.

All our everyday activities are based on multiple online services and products. The computer changed our life three decades ago, and now daily use of the computer is a necessity for everyone to live.

**Top 8 Uses of Computers in the Modern Dynamic Society**

**1. Computers in Education**

Schools and colleges around the world are using computer and internet technologies to teach students digitally and creatively with data visualization. The uses of the computer in a classroom boost the students' creativity and imagination. Every educational institution encourages the students' interaction with computers and many of them have smart classrooms which are **equipped** with interactive whiteboards and laptops or desktop computers for every student. Drawing tools, spreadsheets, audio and video lectures and PowerPoint presentations **contribute to** the effectiveness of the learning process. A lot of colleges and universities provide online *degree programs* and online courses for students, creating a new educational model called a "digital classroom".

## 2. Computers in Business and Trade

Nowadays, computers are totally integrated into business. If you have a computer with an internet connection, you can start a business, run a business or manage a business. Businesses and companies use the computer to do marketing and business planning, to record customer data, to manage services, to keep a record of goods and to **do accounts**. They can conduct job interviews online and hire employees around the world through the use of computer and the internet.

Video conferencing through computers can connect people in various locations, allowing companies and employees to save time and cut travelling costs.

The use of computers in business helps companies to enlarge their customer base faster since many products and services are advertised and sold online. This means that much more people can learn about the company's products. Customers are encouraged to choose the best options and provide feedback to the companies, which means that the companies will become more client-oriented, and the quality of goods and services will improve.

*Transaction* processing which involves transactions between **suppliers**, employees or customers is an important part of business. Computers can perform these banking transactions in a fast, safe and error-free way. Using computers, businesspeople can also analyze investments, sales, expenses, markets and other aspects of business.

Many organizations use computer-based training to instruct their employees in order to save money and improve the *performance* of the staff.

## 3. Computers in Hospitals

Uses of computer in hospitals provide many benefits for doctors and patients. Hospitals can create a database of patients with their personal details and treatment records. Doctors are using a computer to diagnose the diseases of patients faster thanks to various medical *software applications* which can analyze blood and urine tests, X-ray and MRT images, etc. Computers with appropriate software help doctors to monitor the fetus inside the mother's womb. Surgeons nowadays use robotic surgical devices to perform delicate operations and **conduct surgeries** remotely. Virtual reality technologies are also used for training purposes.

## 4. Computers in the Banking Sector

Online banking allows the customer to perform transactions via the internet. We can **transfer** money to any person's account or pay the *mortgage loan*. Banks also provide *ATMs* (Automatic Teller Machines) so that the customer can **withdraw** money from or **deposit** it to their account. Whenever we do that we get messages on our mobile number. We can see and print out our transaction records without visiting banks. The whole process of banking is done by a computer. Also, customers can visit some banks' websites to learn about various bank loan schemes such as business loans, mortgage loans, or car loans. The customer can also check about loan *eligibility* on the bank website and if they are eligible they can apply for the loan online or in a brick-and-mortar bank.

The use of the computer in banking is not only saving our time but also reducing the *infrastructure* cost of banks. Banks have also reduced manual errors through the extensive use of computers.

## 5. Computers in Government Offices

In government sectors, computers are used in *data processing*, maintaining a database of citizens and supporting a paperless environment. Microsoft Office packages have done a great job to **facilitate** the work of the office staff. Excel spreadsheets, PowerPoint presentations and electronic document management have enhanced the speed and quality of office work, reducing the paper flow. E-mail and video conferencing tools save postal and commuting costs.

## 6. Computers in Science and Engineering

Computers with high performance are used to simulate dynamic processes in science and engineering. Supercomputers have numerous applications in the area of research and development. They perform a **wide range of** computationally intensive tasks in various fields, including quantum mechanics, weather forecasting, oil and gas exploration, airplane and spacecraft aerodynamics, etc. Scientists use computers to **plot** and analyze data and to create 3D models which visualize the projected object.

## 7. Computers in Industry and Manufacturing

Computers are used to perform several tasks in industries like managing inventory, planning, designing and creating virtual *samples* of products, production and distribution. Automated *assembly lines* where monotonous repetitive tasks are performed by computers speed up the manufacturing process, improve efficiency and reduce the cost of the product. Online marketing has enabled industries to sell various products in previously inaccessible places like remote **rural** areas.

## 8. Computers in Arts and Culture

Computers are extensively used in all areas of art and culture like design, music, drawing, dancing, or photography. The application of computer technology provides a virtual environment for display and distribution of artwork. The fluid movement of dance can be shown live via animation. Old photos can be scanned into and **retouched** using computers. Unique cultural **heritage** can be **digitized** and popularized using the Internet. Art-lovers can visit museums and other various places of interest via virtual tours.

To conclude, computers have **penetrated** every field of human activity and our dependence on them will only increase in the future.

**Match the terms in Table A with the explanations in Table B.**

Table A

a	mortgage loan
b	transaction
c	degree program
d	eligibility
e	performance
f	data processing
g	software application
h	ATM
i	sample
j	infrastructure
k	assembly line

Table B

1	A machine (usually in a wall outside a bank) from which you take money out of your bank account or do other operations with your money using a special card.
2	How well a person or machine does a piece of work or an activity.
3	The money taken from a bank to buy a house or flat.
4	The exchange of money when you buy or sell something.



5	A computer program that performs a specific function.
6	The right to do or have something because you satisfy the appropriate conditions.
7	Physical structures and facilities, e.g. buildings, roads, power supplies, needed for the operation of an enterprise or the whole society.
8	A small amount or portion that shows what the rest should be like.
9	A process of making a product where it passes along an arrangement of machines and workers, and at each step only a part of the product is made.
10	An integrated course of academic studies to get higher education.
11	The collecting and manipulation of data.

**Find the words in bold that mean the following:**

- 1) broke into, gained access to
- 2) converted into a form that can be processed by a computer
- 3) perform medical operations
- 4) people or companies providing something necessary like products or services
- 5) fitted or furnished with something needed for a particular purpose
- 6) show or present a process, state or development in a form of lines, curves or bars (in a graph or chart)
- 7) (a painting, photograph or other image) improved or repaired
- 8) pay money into a bank account
- 9) keep and sort out the financial records
- 10) move from one place to another
- 11) remove or take away (from a particular place or position)
- 12) make something easier to do
- 13) help by providing money, support of facilities
- 14) values, traditions, languages, culture, or artifacts passed on from generation to generation
- 15) including many different ideas, actions, or things
- 16) absolutely necessary, extremely important
- 17) relating to the countryside

**Задание 2:** выполнить грамматические упражнения.

**1) Which nouns are countable, which ones are uncountable, and which ones can be countable or uncountable depending on the lexical meaning and context?**

data, string, information, performance, processor, supply, software, circuit, hardware, memory, instruction, input, output, technology, motherboard, multimedia, digit, machinery, equipment, wire, research, program, interaction, device

**2) Read the following sentences and choose the correct option.**

1. *The/A* program is not working because *the/some* strings in it contain *the/-* errors.
2. *Some/The* computer mice use wires to connect to *a/-* computer, though there are *the/-* wireless mice as well.
3. *-/The* laptops in my school were outdated and very slow. *The/Some* applications didn't run on them.
4. I need *a/the* new mouse for my computer. *An/The* old one broke when I accidentally dropped it on *a/the* floor.
5. *The/Some* technology issues were discussed at *the/a* conference.
6. *Some/-* hardware is *-/the* visible part of *the/a* computer system.
7. *The/-* technology enabling us to exchange *the/-* instant messages was *the/a* real breakthrough in *a/the* sphere of *the/-* interpersonal communication.
8. Jack's computer crashed and he lost *the/some* important data. *Some/The* data included his

family photo archive and *the/-* collection of Russian textbooks.

9. *A/-* computer user is *the/a* person who uses *a/the* computer system to do *the/some* tasks.

10. To boost *the/-* performance, *a/the* company introduced *the/-* online training courses aimed at improving *some/the* corporate employees' soft skills.

11. For many, *the/-* home computers have become synonymous with Windows and *the/-* Bill Gates, but there have always been *a/the* loyal band of *an/-* Apple Macintosh users.

12. Is your computer *a/the* Mac? Did you know that *the/-* Apple I computer was designed in Jobs' bedroom?

13. *The/A* most popular smartphone model in *the/-* Chinese Republic in *the/-* October 2020 was *an/the* Apple iPhone 11.

#### 5. Порядок выполнения работы:

1) изучение лексики, чтение текста, выполнение послетекстовых заданий;

2) повторение грамматического материала, выполнение упражнений

#### 6. Содержание отчета:

словарный диктант, контроль понимания прочитанного и умения использовать артикл

## Практическое занятие 4. Что такое компьютер?

1. **Цель работы:** изучить новую лексику по теме, повторить грамматические конструкции Passive Voice

2. **Задачи работы:** научиться использовать новые лексические единицы в речи и понимать их в контексте, преобразовывать предложения с действительным залогом в страдательный

3. **Подготовка к работе:** повторение теоретического материала Passive Voice

4. **Задание 1:** прочитать текст и выполнить послетекстовые задания.

### HOW A COMPUTER WORKS

A computer is basically designed to receive, manipulate, store and present data by **execution** of applications, providing a variety of **solutions** through integrated components. It works with the help of programs and represents the **decimal** numbers through a **string** of **binary digits** (0s and 1s). It also has a memory that stores the data, programs, and the result of processing. The components of a computer such as machinery that includes **wires**, transistors, **circuits**, and a hard disk are called hardware, whereas the programs and data are called software.

Here is a simple explanation to hardware and software.

Hardware and software are essential for every computer. **Hardware** is any electronic or mechanical part the user can see and touch. **Software** is a set of instructions, called a program, telling the computer what to do.

The basic parts without which a computer cannot work are as follows:

- **processor**: it executes instructions from software and hardware;

- **memory**: it stores data and instructions and serves as the primary path for data transfer between the processor and storage;

- **motherboard**: it is the part that connects all other parts or components of a computer;

- **storage devices**: they permanently store the data;

- **input devices**: they allow you to communicate with the computer or to input data, e.g. a keyboard;

- **output devices**: they enable you to see the output, e.g. a monitor;

- **power supply unit**: it converts the incoming **alternating electric current (AC)** into a steady **direct current (DC)** and supplies power to the internal components of the computer. Modern personal computers universally use **switched-mode power supplies**, because a switching

regulator provides highest efficiency of power conversion.



*A basic computer system*

**Answer the questions.**

1. What operations are performed with the data after the computer receives it?
2. What numbers represent binary digits?
3. What is the difference between hardware and software?
4. Name the parts which are essential for the computer to work.
5. Why does a computer need a power supply unit?

**Translate into English using the words in bold and in *italics* from exercises 2 and 5:**

служить различным целям, происходить от греческого слова, термин относится к ..., электронное устройство, обрабатывать числовые данные, предоставлять услугу, производить автомобили, ряд приложений, электрическая цепь, устройство вывода, перфокарта, последовательность (строка), двоичное число (двоичная единица информации), аппаратное обеспечение, программное обеспечение, постоянная память, принимать данные, хранить данные, первичные (необработанные) данные, ввод данных, вывод данных, устройство хранения, цифровые вычисления (расчеты), выполнять команды, клавиатура, провод (провода), импульсный стабилизатор напряжения, материнская плата, найти решение проблемы, постоянный ток, переменный ток, десятичная система, блок питания/зарядное устройство

**Задание 2:** выполнить грамматические упражнения.

**1) Read the sentences and underline the subject, the predicate and the object in each sentence. Rewrite the sentences in the Present Simple Passive form. Do not specify who does the action when it seems unnecessary.**

Example 1. People make coffee from coffee beans. → *Coffee is made from coffee beans.*

Example 2. Millions of people drink Cola around the world. → *Cola is drunk by millions of people around the world.*

1. Students learn foreign languages in every school.
2. Thousands of tourists visit the Parthenon every year.
3. The postman delivers newspapers every morning.
4. The kitchen staff serves dinner at 7 o'clock every evening.
5. In Japan and China people eat rice with chopsticks.
6. *Toyota Motor* sells about 10 million cars annually\*.

7. They hold the Olympic Games every four year.
8. In Russia, people celebrate Christmas on January 7.
9. When the weather is cold, the owners of the hotel heat the swimming pool.
10. Mum does the most part of household chores in our family.

---

\* every year

**2) Rewrite the text using Present Simple Passive verbs. Leave out any unnecessary words.**

**HOW A TOY CAR IS MADE**

In the factory, designers use a computer to plan the exact shape of the car. They then feed this computer program into a machine and produce a plastic prototype. Then workers produce the actual toy cars in a factory abroad. As far as the construction is concerned, they make the bodies of the cars from plastic. They add small electric motors to the cars, and then they paint them. They also attach licence plates. Quality control inspects the cars and then the workers wrap them and pack them into cardboard boxes. Then the manufacturer ships the cars to Britain.

- a) *At the first step, a computer is used to plan the exact shape of the car.*
- b) Then ... and ....
- c) The actual ....
- d) The bodies ....
- e) Small .... Licence ....
- f) At the next stage, ....
- g) Finally, ... Britain.

**5. Порядок выполнения работы:**

- 1) изучение лексики, чтение текста, выполнение послетекстовых заданий;
- 2) повторение грамматического материала, выполнение упражнений

**6. Содержание отчета:**

словарный диктант, контроль понимания прочитанного, продуктивная речь по теме с применением новых ЛЕ и глаголов в страдательном залоге

## Практическое занятие 5. Типы компьютеров

1. **Цель работы:** изучить новую лексику по теме, повторить степени сравнения прилагательных и наречий
2. **Задачи работы:** научиться использовать новые лексические единицы в речи и понимать их в контексте, сравнивать объекты, применяя степени сравнения прилагательных и наречий
3. **Подготовка к работе:** повторение теоретического материала «Степени сравнения прилагательных и наречий»
4. **Задание 1:** прочитать текст и выполнить послетекстовые задания.

### FROM MAINFRAMES TO WEARABLE COMPUTERS

1. A **mainframe** is the most powerful type of computer. It can process and store large amounts of data. It supports multiple users at a time and can perform more **simultaneous** processes than a PC. Its central system is a large server connected to hundreds of terminals over a network. Mainframes are used for **large-scale** computing purposes in banks, big companies and

universities.

**Supercomputers** are the most powerful mainframes used for a wide range of computationally intensive tasks, primarily scientific. A supercomputer can be the size of two tennis courts. If you were able to perform one calculation per second, it would take you 2.3 trillion days, or 6.23 billion years to do what Summit, the world's second most powerful supercomputer, can do in one second. Its system is made up of 4608 computer *servers*. Since June 2020, the Fugaku supercomputer built by *Fujitsu*, Japan, has been the world's fastest supercomputer. It was named after the famous Mount Fuji and has 7,630,848 *cores*.

2. A **workstation** is a type of computer used for engineering applications (*CAD/CAM*), *desktop publishing (DTP)*, *software development*, and other types of technical or scientific applications that require a **moderate** amount of computing power and relatively high quality graphics **capabilities**. Workstations generally come with a large, **high-resolution** graphics screen, a large amount of random-access memory (RAM), **built-in** network support, and a *graphical user interface (GUI)*. Most workstations also have a mass storage device such as a disk drive, but a special type of workstation, called a diskless workstation, comes without a disk drive. A diskless workstation loads its *operating system* from a server. Workstations commonly use Microsoft Windows or Linux systems. Like personal computers, most workstations are single-user computers. However, workstations are typically linked together to form a *local-area network (LAN)*, although they can also be used as *standalone* systems.

N.B.: In networking, a 'workstation' refers to any computer connected to a local-area network. It could be either an actual workstation or a personal computer.

3. A **desktop PC** can be defined as a small, relatively inexpensive computer designed for an individual user. The term "desktop computer" was recorded as early as 1958 when people could only dream about a computer that could fit on a desk instead of devices that filled up an entire room. The first desktop personal computer, IBM PC, was released on August 12, 1981. Desktop computers are based on microprocessor technology that enables manufacturers to put an entire central processing unit (CPU) on one chip. They are used as *end-user* computers in the home or as workstations for group work. Businesses use personal computers for *word processing*, accounting, desktop publishing, and for running spreadsheet and database management applications. The most popular use for personal computers at home is for playing games, *surfing the Internet* and working remotely from home. Every desktop PC has its own central processing unit, monitor and keyboard. According to the name, desktop computers are designed to be placed on your desk; however, many users put the tower under the desk.

4. A **laptop PC** is a *lightweight* computer that you can transport easily. Smaller and lighter laptops that **incorporate** a display roughly the size of A4 paper are called **notebooks**. Low-performance and inexpensive notebooks that have less processing speed and less memory were known as **netbooks**. Though the name has fallen out of use, machines matching their description remain an important part of the market for laptops running Microsoft Windows. They are used primarily for accessing the Internet and have a special "children's" edition with smaller keyboards.

Laptops combine all the input/output components of a desktop computer, including the screen built in the top panel (cover), speakers, data storage device, a processor, memory and a keyboard into a single unit. They can work as fast as desktop PCs, with similar processors, *memory capacity*, and disk drives, but they are *portable* and have a smaller screen. Modern notebooks have a *TFT (Thin Film Transistor) screen* or an *LCD (Liquid Crystal Display)* that produces very sharp images.

Instead of a mouse, they have a *touchpad* built into the keyboard – a sensitive pad that you can

touch to move the *pointer* on the screen.

Laptops offer a lot of *connectivity* options: USB (Universal Serial Bus) ports for connecting peripherals, slots for memory cards, etc. They come with *battery packs*, which let you use the computer when there are no *electrical outlets* available.

5. **Tablet PCs** are mobile devices which have a mobile operating system, touchscreen display and a *rechargeable* battery in a single thin and flat package. A tablet PC looks like a book, with an LCD on which you can write using a *stylus* – a special digital pen, or your fingers. Your handwriting can be recognized and converted into **editable** text. You can also type at the *detached* keyboard or use *voice recognition*. Being highly mobile, tablets are also **versatile**: popular uses include viewing presentations, video-conferencing, reading e-books, watching movies, sharing photos, etc.

6. A **personal digital assistant (PDA)** or **handheld PC** is a tiny computer that can be held in one hand. The term PDA refers to a wide variety of *hand-held devices*, *palmtops* and *pocket PCs*. For input, you type at a small keyboard or use a stylus to select items, draw pictures, etc. Some models incorporate handwriting recognition, which enables a PDA to recognize **characters** written by hand. Some PDAs recognize spoken words by using voice recognition software. They can be used as mobile phones or as personal organizers for storing notes, reminders and addresses. They also let you *access* the Internet **via** *wireless technology*, without cables. Today PDAs have been mostly displaced by highly capable smartphones.

7. A **wearable computer** is a computing device worn on the user's body. It runs on batteries and is typically worn on a belt or wrist, hung from the neck, strapped to the arm or leg, or on the head. Wearables are designed for mobile or *hands-free operation*. Some devices are equipped with a wireless modem, a small keyboard and a screen; others are voice-activated and can access e-mail or voice mail. Examples of wearable computers are wristwatches like the Apple Watch, fitness trackers, optical head-mounted displays like Google Glass, and *heart pacemakers*.

**Find the words in italics that mean the following:**

сенсорная панель, электронная обработка (редактирование) текста, электрическая розетка, комплект батарей (аккумуляторная батарея), подзаряжаемый, сенсорное перо, распознавание голоса, бесконтактное управление, отдельный (не прикрепленный), возможность подключения (соединения, установления связи), ёмкость запоминающего устройства (памяти), операционная система, (конечный) потребитель, разработка программного обеспечения, настольная издательская система, кардиостимулятор, жидкокристаллический монитор (дисплей), графический интерфейс пользователя, тонкопленочный транзистор, локальная сеть, выходить в интернет, автономный (не подключенный к сети), курсор, беспроводная технология, просматривать веб-страницы («лазить, сидеть» в Интернете), ядро (процессора)

**Match the terms in Table A (in the text they are in italics) with the statements or explanations in Table B.**

Table A

a	CAD (Computer-Aided Design)
b	CAM (Computer Aided Manufacturing)
c	server
d	LCD (liquid-crystal display)
e	DTP (desktop publishing)
f	GUI (graphical user interface)
g	pointer

Table B

1	A type of flat-panel screen.
---	------------------------------

2	When you are typing, it shows you the current position in the text.
3	Technology for automating the process of design and writing technical documentation.
4	A computer program that enables a person to communicate with a computer through the use of symbols, e.g. icons.
5	A computer system that provides functionality, services and data to other computers.
6	The use of software and computer-controlled machinery to automate a manufacturing process.
7	It allows you to make page designs which integrate text and images, using special software on your computer.

**Задание 2:** выполнить грамматические упражнения.

**1) Complete the text with adjectives from the list, using a positive, comparative or superlative form.**

cheap	fast	great	careful	important	difficult
up-to-date	serious	essential	tricky	late	dangerous

#### COMPUTERS TODAY

Nowadays using computers is absolutely a) \_\_\_\_\_. We can't do without them, and you don't have to be an expert to use one, as using a computer today is b) \_\_\_\_\_ than it used to be. You don't need to be rich either, as computers are also becoming c) \_\_\_\_\_ and \_\_\_\_\_ as time goes on. Also, if you are studying, the Internet is of d) \_\_\_\_\_ importance as a place to find information. Two decades ago this used to take a long time, but the e) \_\_\_\_\_ machines are a great improvement. The f) \_\_\_\_\_ the computer, the g) \_\_\_\_\_ it works. However, the problem of viruses has become h) \_\_\_\_\_ as viruses are becoming i) \_\_\_\_\_. The Internet has become a j) \_\_\_\_\_ place as well, so it is k) \_\_\_\_\_ to be very l) \_\_\_\_\_ when you go online.

**2) Complete the text using the positive, comparative and superlative forms of adjectives and adverbs in brackets. Add *the* where necessary.**

#### LAPTOPS VS. DESKTOPS

When deciding between purchasing a desktop or a laptop computer, you'll need to consider a handful of criteria and determine what fits your needs a) \_\_\_\_\_ (good).

1. Cost

Today a variety of component options available for laptops is almost as b) \_\_\_\_\_ (wide) as for desktops, but still c) \_\_\_\_\_ (limited). While desktops can start as d) \_\_\_\_\_ (low) as \$400 for a full package, the price for a e) \_\_\_\_\_ (powerful) laptop can be considerably f) \_\_\_\_\_ (high).

2. Portability

Desktops are g) \_\_\_\_\_ (large) in size and have a separate monitor. Laptops are very portable due to their h) \_\_\_\_\_ (compact) size. They are great for on-the-go use.

3. Processor

Laptop processors have nearly **caught up to**\* desktop processors. Gaming laptops can have an equal performance, but they are much i) \_\_\_\_\_ (expensive).

4. External Storage

Though laptop and desktops computers can both connect to multiple external drives, the number of ports on a laptop is j) \_\_\_\_\_ (few) than on a desktop computer.

5. Keyboard

Laptops with the 14" and 15" screens have k) \_\_\_\_\_ (small) keyboards and don't feature a **numpad**\*\* on the right side. Laptops with 17" screens have l) \_\_\_\_\_ (large) keyboards and may include a numpad, but these laptops are m) \_\_\_\_\_ (**bulky**\*\*\*) and n) \_\_\_\_\_ (heavy).

6. Upgrading

Most components in a desktop are removable, making it o) \_\_\_\_\_ (easy) to upgrade, whereas about the only components that can be upgraded in a laptop are memory and hard drive. The remaining components are either built-in and cannot be removed, or the laptop is not designed to work with the upgraded component. If you need to upgrade p) \_\_\_\_\_ (many) components (anything other than the hard drive and memory), you'll require a new laptop.

In the end, the final decision depends on what your needs are. If price and portability are q) \_\_\_\_\_ (important) than functionality, the laptop is r) \_\_\_\_\_ (great) option. If you want a computer that can be upgraded s) \_\_\_\_\_ (easily) or aimed at graphic intensive gaming, the desktop is t) \_\_\_\_\_ (fine) choice.

\* (BE **catch up with**) move or make progress fast enough to reach or join someone or something that is in front

\*\* a section on the far right of the computer keyboard for entering numbers

\*\*\* taking much space, large and heavy

#### 5. **Порядок выполнения работы:**

1) изучение лексики, чтение текста, выполнение послетекстовых заданий;

2) повторение грамматического материала, выполнение упражнений

#### 6. **Содержание отчета:**

словарный диктант, контроль понимания текста и ЛЕ, продуктивная речь с использованием новых ЛЕ и степеней сравнения прилагательных и наречий, самостоятельное составление краткого текста о типах компьютеров

## Практическое занятие 6. Устройства ввода. Устройства ввода: клавиатура и мышь

1. **Цель работы:** изучить новую лексику по теме, повторить грамматические конструкции «Условные предложения 0 и 1 типов»

2. **Задачи работы:** научиться использовать новые лексические единицы в речи и понимать их в контексте, использовать условные предложения в речи

3. **Подготовка к работе:** повторение теоретического материала «Условные предложения 0 и 1 типов», вводные вопросы к теме «Устройства ввода»

**Compare the following definitions of input devices. Which one gives the clearest explanation?**

1. An **input device** is any hardware device that sends data to a computer, allowing you to interact with and control it. (www.computerhope. com)

2. An **input device** is a piece of equipment used to provide data and control signals to an information processing system such as a computer or information appliance. (Wikipedia)

3. An **input device** is a term for physical piece of hardware that connects to a primary device, such as a computer, in order to provide user input. (www.technopedia. com)

4. An **input device** is any hardware device that sends data to a computer, allowing you to interact with it and control it. It allows input of raw data to the computer for processing. (teachcomputerscience.com)

Computer mouse, keyboard, and microphone are examples of input device. Can you think of more examples of input device? What input devices do you use to feed data into your computer at home?

4. **Задание 1:** прочитать текст и выполнить послетекстовые задания.

### THE KEYBOARD

A computer keyboard is an input device that allows a person to enter letters, numbers and other symbols (called characters) into a computer. It is one of the most used input devices for computers. Using a keyboard to enter plenty of data is called typing.





### *A standard English US full-size wired keyboard*

A keyboard contains many mechanical *switches* or *push-buttons* called **keys**. When one of these is pushed, an electrical circuit is closed, and the keyboard sends a signal to the computer that tells it what letter, number or symbol has to be shown on the screen. The computer's CPU then shows the character on the screen, usually at the place where the *cursor* is. Besides keys for entering characters, computer keyboards also have keys that change the symbol (such as *Shift* or *Caps Lock*) or give the computer special commands (such as the *arrow keys*, *Ctrl* and *Alt*). These keys depend on the operating system which the keyboard is being used with. A keyboard can be joined to a computer using a wire, but it can also be wireless (like those that use Bluetooth). Today, most keyboards that use wires connect to a USB (Universal Serial Bus) port on the computer, but older ones used a type of port called PS/2 (Personal System/2), which was slower than USB.

### **Answer the questions.**

1. What does an input device do?
2. What is the keyboard used for?
3. When you press a key, what happens inside the computer?
4. How can a keyboard be joined to a computer?

## THE COMPUTER MOUSE

A computer mouse is a handheld hardware input device that controls a cursor in a *GUI* (*graphical user interface*) and can move and select text, icons, files, and *folders* on your computer.

For desktop computers, the mouse is placed on a **flat** surface (e.g. *mouse pad* or desk) in front of your computer. A typical desktop computer mouse has two buttons and a wheel.

### History of Computer Mouse

#### The roller ball

It was not until the mid-80s that the computer mouse, in the sense it is seen today, appeared. But the fact is that the technology behind the computer mouse was invented far earlier. It was the trackball designed by Ralph Benjamin after World War II, and it was used to track aircraft on the radar. The device was called *roller ball* and was patented in 1947.

The ball was on top of rotating metal plates which in turn lay in contact with cables. These early versions of trackballs were quite clumsy to use.

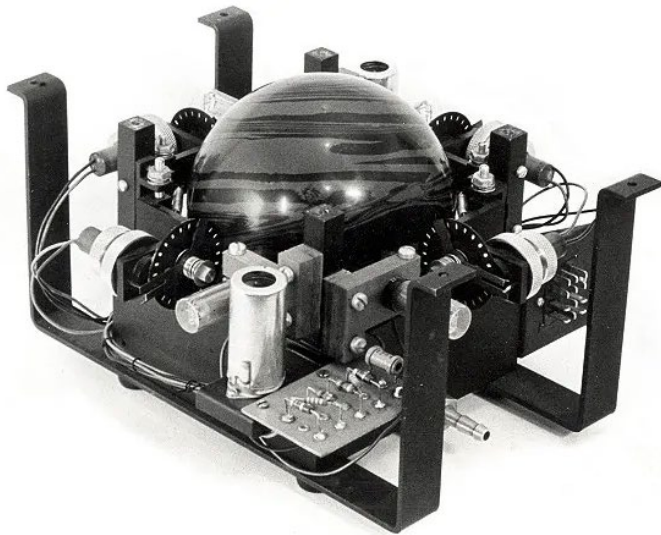

*This trackball was designed in 1952 by Fred Longstaff and Tom Cranston for the Royal Canadian Navy. It featured a small bowling ball for the track ball instead of a specially designed metal ball, because, according to **rumours**, they did not receive as much funding for the project*

The first mouse

The first real mouse was invented by Douglas Engelbart in the early 1960s. He developed this extremely helpful device to make it easier to navigate his oNLine System (NLS), the “**ancestor**” of the Internet that allowed computer users to share the information stored on their computers. The project was funded from the U.S. Department of Defense’s Advanced Research Projects Agency. NLS was also the first system to successfully use *hypertext*<sup>1</sup> to link files (making information available through a click of the mouse).

Engelbart’s computer mouse was presented at Stanford University on December 9, 1968, at a computer demonstration later named “The Mother of All Demos”. This 90-minute presentation demonstrated almost every fundamental element of modern computing: windows, hypertext, graphics, video conferencing, word processing, a collaborative real-time editor, etc.



*The first computer mouse had a wooden case!*

The first computer mouse was housed in a wooden box twice as high as today’s mice. It moved with the help of two metal wheels on its underside. The wheels sat at a right angle. When the mouse was moved, the vertical wheel rolled along the surface while the horizontal wheel slid sideways. First mice had three buttons on top.

Why is the computer mouse called a “mouse”?

Some people believe that the name “mouse” is an **acronym**, meaning “**manually-operated user-select equipment**”. However, that is not true. Douglas Engelbart called his device a mouse because it **resembled the rodent**: it had a cord attached to its rear part, suggesting the idea of a

---

<sup>1</sup> A text which contains links to other texts, graphics, video, or sound.

tail.

Which hand should be used to control the mouse?

*By default*, a computer mouse is set up to be used with your right hand. However, if you are left-handed, it can be set up to be used with your left hand. **Ambidextrous** mice symmetrical in shape, which makes them suitable for both right- or left-handed users, are also available today.

“Mice” or “Mouses”?

Of course, when talking about the small rodent we always say “mice”. However, there are no official rules regulating the use of the plural form for “computer mouse”. Actually, both forms are acceptable, though “mouses” is starting to **take off**. Surveys say that people would rather think of “mice” as an irregular plural unique to the animal. To prevent confusion, some companies and writers avoid using either plural form of a mouse by referring to multiple mice as “mouse devices”. Interestingly, Douglas Engelbart preferred the “mice” option!

Since the time it first appeared on the market, over one billion computer mice have been sold in the world.

**Complete the text with the verbs listed below.**

click	hover	double-click	drag	grab	select	move	control
-------	-------	--------------	------	------	--------	------	---------

A mouse allows you to 1) \_\_\_\_\_ the cursor and move around the screen very quickly. Making the same movements with the arrow keys on the keyboard would take much longer. As you 2) \_\_\_\_\_ the mouse on your desk, the pointer on the screen moves in the same direction. The pointer usually looks like an I-bar, an arrow or a pointing hand, depending on what you are doing.

A regular mouse has two or more buttons to communicate with the computer. For example, if you want to place the insertion point or choose a menu option, you just 3) \_\_\_\_\_ on the mouse button, and the option is chosen.

The mouse is used to 4) \_\_\_\_\_ text and items on the screen. For example, you can highlight the line in the text to be deleted, or you can do it with the entire document.

The mouse is widely used in graphics and design. When you want to move an image, you position the pointer on the object you want to move, press the mouse button, and 5) \_\_\_\_\_ the image to a new location on the screen. Similarly, the mouse is used to change the shape of a graphic object. For example, if you want to convert a square into a rectangle, you 6) \_\_\_\_\_ one corner of the square and stretch it into a rectangle.

The mouse is also used to start a program or open a document: you put the pointer on the file name and 7) \_\_\_\_\_ on the file name – i.e. you rapidly press and release the mouse button twice. If you 8) \_\_\_\_\_ the mouse over an object, some additional information about the object can be seen on the screen, on condition that it is attached to the object.

**Задание 2:** выполнить грамматические упражнения.

**1) Complete the zero conditional sentences with the correct form of the verbs from the box.**

be	enter	leave	switch	come	walk	open
----	-------	-------	--------	------	------	------

### THE AUTOMATIC HOUSE

1. When your car \_\_\_\_\_ the drive, the garage doors open.
2. If you \_\_\_\_\_ into the room, the lights come on.
3. When you sit on the sofa, the TV \_\_\_\_\_ on.
4. When you touch the taps, water \_\_\_\_\_ out.
5. When it is hot, the windows \_\_\_\_\_.
6. If it \_\_\_\_\_ cold, the heating system turns on.

7. If you \_\_\_\_\_ the house, the door locks itself.

**2) Complete the first conditional sentences with the correct form of the verbs in brackets, Present Simple or will/can/may + V. Use contracted forms. In some sentences with will/can/may + V more than one answer may be possible.**

### CREDIT CARD FRAUDS\* – THE FACTS

Your credit card information can be stolen right under your nose. If a credit card thief a) \_\_\_\_\_ (get) the chance, he b) \_\_\_\_\_ (steal) your card or your money.

If a thief c) \_\_\_\_\_ (get) access to your credit card information, he d) \_\_\_\_\_ (profit) from it in a few different ways. All of them can make life more difficult for you.

If thieves e) \_\_\_\_\_ (have) your credit cards details, they f) \_\_\_\_\_ (use) your credit card information to buy things over the internet. It g) \_\_\_\_\_ (be) much easier for them to do this if they also h) \_\_\_\_\_ (have) the three-digit security code from the back of your credit card. If they i) \_\_\_\_\_ (learn) more information about you like your name, address and date of birth, they j) \_\_\_\_\_ (sell) your credit card information on the dark web – and the more details they have, the more it is worth.

How can you prevent your credit card details theft? There are several ways:

1. Always cover your PIN number when you use it. If you k) \_\_\_\_\_ (not cover) it, someone l) \_\_\_\_\_ (see) it.

2. Don't talk to people at the ATM – a thief m) \_\_\_\_\_ (try) to confuse you by talking to you if you n) \_\_\_\_\_ (allow) him to.

3. You need good security on your computer – thieves o) \_\_\_\_\_ (be able to) get into your accounts if you p) \_\_\_\_\_ (not have) proper security.

4. When you buy something on the Internet, make sure the website has a 'locked' symbol. If it q) \_\_\_\_\_ (not have) one, the transaction r) \_\_\_\_\_ (not be) secure enough.

5. Don't forget, if you s) \_\_\_\_\_ (tell) your PIN number to another person and your money t) \_\_\_\_\_ (be stolen), your credit card company u) \_\_\_\_\_ (not return) your money.

If you have found out that your credit card information has been stolen, contact the bank that issued your card. If you v) \_\_\_\_\_ (prove) that the card details have been stolen, the credit card issuer w) \_\_\_\_\_ (cancel) your old credit card account, x) \_\_\_\_\_ (remove) the **fraudulent\*\*** transactions from your account, and y) \_\_\_\_\_ (send) a new credit card and a new credit card number.

\_\_\_\_\_

\* cheating, scam

\*\* dishonest, false

### **5. Порядок выполнения работы**

1) изучение лексики, чтение текста, выполнение послетекстовых заданий;

2) повторение грамматического материала, выполнение упражнений

### **6. Содержание отчета:**

словарный диктант, контроль понимания прочитанного, продуктивная речь по теме с применением новых ЛЕ и условных предложений 0 и 1 типа

## Практическое занятие 7. Устройства вывода: принтеры и их типы.

### Устройства вывода: монитор

- 1. Цель работы:** изучить новую лексику по теме, повторить грамматические конструкции Present Perfect
- 2. Задачи работы:** научиться использовать новые лексические единицы в речи и понимать их в контексте, пользоваться Present Perfect в речи
- 3. Подготовка к работе:** повторение теоретического материала Present Perfect, проверка базовых знаний об устройствах вывода  
Answer the questions:

Can you name the type and make of the monitor or display your computer has?

Do you know the size of the screen in inches?

Can you change the settings to alter the quality of the image?

Is it possible to watch TV channels using your monitor?

Can your TV serve as a computer monitor?

What other output devices do you know?

- 4. Задание 1:** прочитать текст и выполнить послетекстовые задания.

#### Types of Printer

##### **1. Dot-matrix printers**

The first dot-matrix printer was created by IBM in 1957.

To create an image, a dot-matrix printer uses print heads containing from 9 to 24 pins. The print head sits over an ink ribbon which rests above a piece of paper. As the print head moves across the ribbon (usually horizontally), the pins press into the ribbon to imprint ink onto the page, like in a typewriter. Due to this technique, images and characters are built up of multiple dots, hence the name of this type of printer. Dot-matrix printers can print text and graphics, but the resolution of the output is relatively low – 72 to 180 dpi.

ystem where a  
ld allow us t  
mercial supplier.

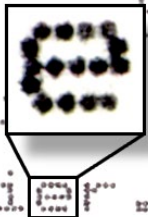

Sample output from 9-pin dot matrix printer

##### **2. Inkjet printers**

Inkjet printers operate by spraying tiny ink droplets onto paper to form a required image. The print head has several tiny *nozzles*, also called *jets*. As the paper moves past the print head, the nozzles project ink onto it, forming the characters and images. There is usually one black ink cartridge and one “colour” cartridge. Some models might require separate cartridges for each primary pigment, along with a black ink cartridge. Colours and **hues** are created by the mixing of the primary pigments (**cyan**, **magenta**, yellow, and black).

An inkjet printer can produce from 100 to several hundred pages, depending on the nature of the hard copy, before the ink cartridges must be replaced. A copy from an inkjet printer needs some time to dry, as it comes out wet. Inkjet printers are comparatively fast, quiet and cheap.

##### **3. Laser printers**

Laser printers were invented at Xerox PARC in the 1970s by Gary Starkweather.

A laser printer uses a focused laser beam or light to transfer text and images onto paper. It utilizes microscopic ink particles in a powdered form known as *toner*. An electrical charge is used to

attract toner particles to a *transfer roller*. Toner particles are pressed onto a piece of paper, while heat and pressure from the *fuser unit* make them melt, causing the image to be permanently fixed onto the page.

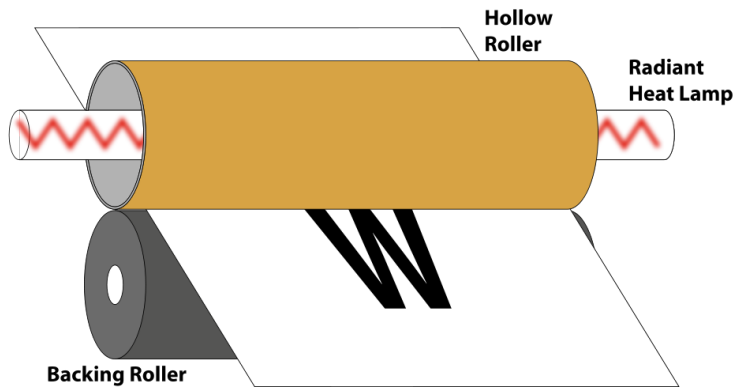

*Paper moves through two fuser rollers. The lower backing roller helps create pressure. The upper roller is hollow and contains a heater. Toner is fused onto paper with heat and pressure*

Among the disadvantages of laser printers are high energy consumption, bulkiness, and high cost. However, compared to the cost of the unit, the cartridges and *cartridge refill* are quite cheap and they last longer than ink cartridges, allowing for up to 5000 pages of output.

#### **4. Thermal transfer printers**

The first thermal printer was invented in 1965 by John Kirby, an outstanding American electrical engineer, a Noble prize winner in physics (2000). The first thermal transfer label printer was produced in 1981.

Thermal transfer printers use a thermal print head, which consists of a row of tiny heating elements, to transfer a *solid ink* from a ribbon onto a label substrate (usually made from vinyl, polyester, nylon, or other thicker materials) to produce a permanent print. In Xerox solid ink printers, rectangular ink blocks, which resemble candle wax, are loaded into the top of the printer. Next, the ink blocks are melted and the liquid ink is transferred onto the oil-coated print drum. When the paper is pushed over the print drum, the image is transferred onto the surface. The paper used in thermal printers has a special coating that turns dark grey when heated.

#### **5. Imagesetters and Platesetters**

The history of imagesetters goes back to the printing press known since the 16<sup>th</sup> century (Johannes Gutenberg's printing press). The first imagesetter was designed by Victor Gassiyev, a Soviet inventor. In 1897 he completed the first machine ever that could print text by means of photographic transfer.

An imagesetter is a high resolution output device that can transfer electronic text and graphics directly to film, printing plates or photo-sensitive paper, usually in large format. Designs are typically created using Adobe Illustrator, CorelDraw or other CADs, design and desktop publishing software packages and are typically in PDF format.

The print workflow of older imagesetters is called *CtF (computer to film)*. An imagesetter puts the digital image or text onto a piece of film and then the printing press burns it onto a *printing plate*. The film is the same as that used in a regular camera, but in larger sheets, and goes through the same chemical process of *developing, stopping and fixing*.

Today the CtF is being replaced by the more advanced *CtP (computer to plate)* technology. The type of imagesetter used is called a *platesetter*. A platesetter outputs the images created in a DTP program directly to the printing plate, which can be up to 1422×1804 mm.



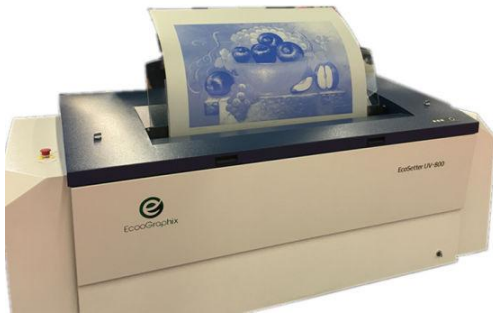

An EcooGraphix platesetter, China

## 6. Plotters

Plotters are machines used to produce *vector graphics*<sup>2</sup>. Plotters use ink and *fine pen* held in a *carriage* to draw detailed designs on paper, or a small knife to carve images on vinyl or leather. The pen or knife is mechanically run over the material to create text or images. Early pen plotters appeared in the 1950s. They were used to print out construction plans, engineering drawings and technical illustrations. Today they have almost fallen out of use, being replaced by wide-format conventional printers based on inkjet or toner technology. These devices have come to be called plotters as well.



A modern carving plotter

---

<sup>2</sup> Computer graphics images consisting of points, lines and curves based on mathematical formulae. Unlike bitmapped images, vector images can be scaled up to any resolution without losing quality, as they are not made up of dots, or pixels. The most common vector image formats include PDF (Portable Document Format), SVG (Scalable Vector Graphics), AI (Adobe Illustrator), and EPS (Encapsulated PostScript).

## 7. 3D printers

3D printing is a process of making three-dimensional solid objects from a CAD model or a digital 3D model. It enables to produce complex shapes using less material than in traditional manufacturing. The approach to industrial production in 3D printing is called *additive manufacturing*, the process of creating an object by adding material to build one layer of the object at a time. It is the opposite of conventional *subtractive manufacturing*, in which an object is created by removing material from a solid block until the final product is complete.

3D printable models may be created with a CAD package, via a 3D scanner, or by a plain digital camera. The manual modelling process of preparing geometric data for 3D computer graphics is similar to plastic arts such as sculpting. Also, 3D scanning can be used to collect digital data on the shape and appearance of a real object to create a digital model based on it. Errors in 3D printable models can be identified and corrected before printing.

Some methods used in 3D printing

The technology used by most 3D printers to date is *fused deposition modelling (FDM)*, a special application of plastic *extrusion*, developed in 1988 by S. Scott Crump and commercialized by his company *Stratasys*. The FDM technology is also known as *fused filament fabrication (FFF)*

technology, as it uses *filament* (a thermoplastic material) to build up the designs. A filament is melted and deposited in layers through the heated *extrusion nozzle*.

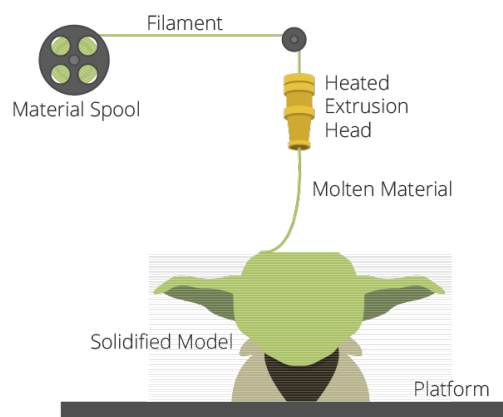

*Baby Yoda's parts were printed separately using the FFF technology and then assembled*

Another technology used in 3D printing is stereolithography. A UV-laser is used to draw a pre-programmed design or shape onto an ultraviolet-sensitive photopolymer surface. The polymer hardens where the beam touches it, and the object is “printed” layer by layer.

The only disadvantage of 3D printers is their high cost. However, by 2021 entry level machines became affordable for most people, as they can be found for less than \$200. These affordable printers are usually FDM printers.

3D printing is extremely practicable, as it enables the designers to quickly turn concepts into physical prototypes and make necessary changes immediately. The most important applications of 3D printing are manufacturing, medicine, architecture, art and design. Among the items made by 3D printers are shoes designs, furniture, various tools, toys, wax models for jewellery, car parts, sculptures, architectural designs, etc. Archaeologists can reconstruct dinosaur skeletons and other fossils. Medical technicians can make *prosthetics*, hearing aids, artificial teeth and bones. It is obvious that 3D printing can be applied universally.



*The Naturalis Biodiversity Center used 3D scanning and 3D printing technology in order to reconstruct the Triceratops*

**Match the types of printer in A with their Russian names in B.**

A	B
1 dot-matrix	a) фотонаборный автомат
2 plotter	b) термографическое печатное устройство (термопечать)
3 imagesetter	c) (точечно-) матричный принтер
4 platesetter	d) струйный принтер
5 inkjet	e) чертежный автомат (графопостроитель)
6 thermal transfer printer	f) автомат для изготовления печатных форм

THE MONITOR



A computer monitor is an output device that displays information in visual form. The term “monitor” is often used synonymously with “computer screen” or “display”. The monitor interprets and displays the graphical output signal from the computer’s graphics card and displays it on the screen. The monitor is the most used output device on a computer system.

What is an LCD display?

A monitor usually comprises the visual display, circuitry, casing, and power supply. An LCD display is made of two panels (also called *substrate*) made of polarized glass material free of sodium with a thin layer of liquid crystal material between them. An array of small segments or pixels is used to display the information. As LCDs do not emit light themselves and need other light sources, they use a backlight system at the rear of the monitor. First, the light passes through the first substrate. Then the crystals block the light in different quantities before it passes through the second substrate and use three filters to distinguish three primary colours: red, blue and green. The multi-colour image is obtained by combining these three colours for each pixel on the screen. The three elements of red, green and blue that together compose a pixel are called *subpixels*.

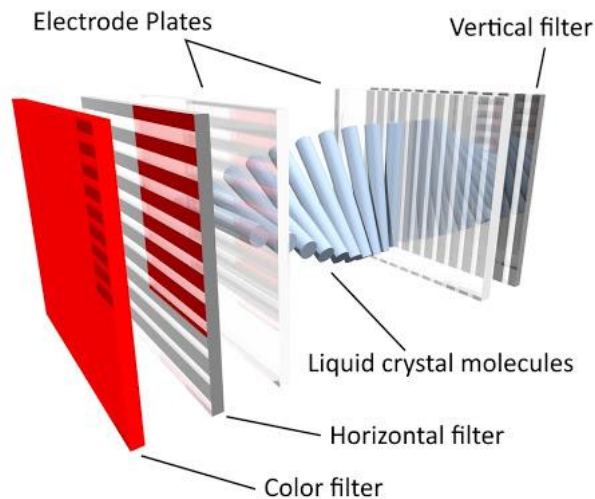

*A subpixel of a colour LCD display. The crystal cells are arranged in a twisted spiral form due to the twisted nematic effect*

The optical configuration of an LCD has a “sandwich” structure. It typically includes a front polarizer (analyzer), a back (rear) polarizer cross-positioned to the front polarizer in terms of polarization, and a liquid crystal layer between them. The liquid crystal panel is illuminated by a light source at the back of the unit. The colour is obtained using three colour filters.

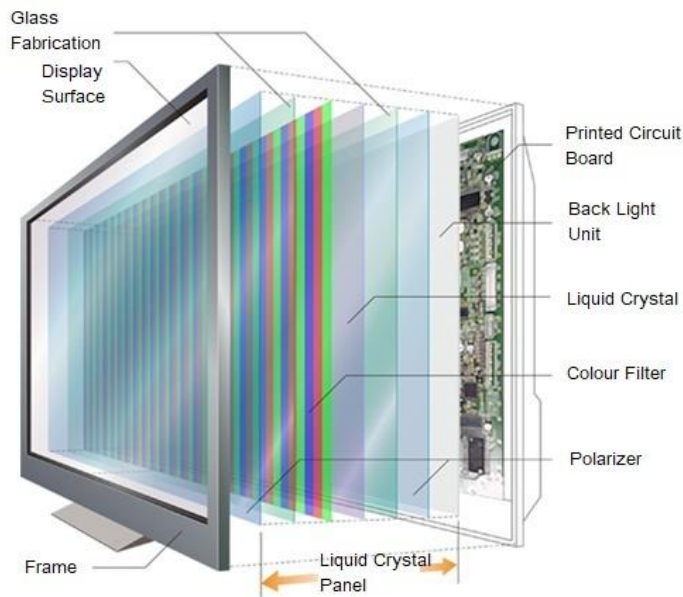

*The typical multi-layered structure of an active-matrix liquid crystal display*

**Complete the definitions with the words from the box.**

subpixel   aspect ratio   luminance   burn-in   resolution   colour depth   latency
---

1. \_\_\_\_\_ is the number of bits used for each colour component of a single pixel, measuring the overall number of colours the monitor can support.
2. A \_\_\_\_\_ is one of the three components that make up a pixel.
3. \_\_\_\_\_ is a permanent and noticeable loss of colour or “ghosting” of a previous image on a digital display, occurring when certain pixels are used more often than other.
4. \_\_\_\_\_ is the width of the screen in proportion to its height.
5. \_\_\_\_\_ is the quantity and intensity of light emitted by an LCD screen and projected on the screen surface.
6. \_\_\_\_\_ is the difference between the time when there is signal input and the time it is displayed on the screen.
7. \_\_\_\_\_ is the number of pixels along the width and height of the monitor.

**Задание 2:** выполнить грамматические упражнения.

**1) John’s old computer, which he has had for 13 years, has suddenly stopped working. There may be various reasons why it has happened this time. Put the words in brackets in the Present Perfect form, affirmative or negative. The computer isn’t working because ...**

1. it \_\_\_\_\_ (overheat).
2. RAM \_\_\_\_\_ (get) damaged.
3. John \_\_\_\_\_ (kicked) the computer unintentionally and head crash \_\_\_\_\_ (occur).
4. the monitor cable \_\_\_\_\_ (disconnect).
5. John \_\_\_\_\_ (start) a malfunctioning app.
6. John \_\_\_\_\_ (not update) the anti-virus software and he \_\_\_\_\_ (not run) a scan for a long time, so the viruses \_\_\_\_\_ (cause) a sudden computer crash.

**2) Ask each other questions using Present Perfect and *ever*.**

- *have a virus on your PC*
- make your own website

- fix a serious problem with someone else's PC
- create an app for smartphones
- drop your smartphone
- write a virus
- delete a file by mistake
- forget to save changes to a document
- see your computer screen go blank
- shout and hit the roof because of your computer's bad performance

Example: *Have you ever had a virus on your computer?*

#### 5. Порядок выполнения работы

- 1) изучение лексики, чтение текста, выполнение послетекстовых заданий;
- 2) повторение грамматического материала, выполнение упражнений

#### 6. Содержание отчета

словарный диктант, контроль понимания прочитанного, продуктивная речь по теме с применением новых ЛЕ и глаголов в Present Perfect

## Практическое занятие 8. Устройства хранения: магнитные накопители

1. **Цель работы:** изучить новую лексику по теме, повторить грамматические конструкции Past Simple и Past Perfect

2. **Задачи работы:** научиться использовать новые лексические единицы в речи и понимать их в контексте, правильно использовать глагольные формы Past Simple и Past Perfect

3. **Подготовка к работе:** повторение теоретического материала Past Simple и Past Perfect

#### Answer the questions.

How many storage devices can you name? What storage devices do you have? What sort of data do you store on your flash-drives? What is the storage capacity of your computer, laptop and smartphone?

How can people record and store information? What are the advantages of digital storage over the conventional types of storage? What are the disadvantages of electronic storage?

4. **Задание 1:** прочитать текст и выполнить послетекстовые задания.

### Magnetic Storage Devices

#### 1. Floppy disks

Almost every computer in the past used to have a floppy disk drive. Today floppy disks or floppy diskettes are virtually obsolete devices, having been replaced by higher capacity technology such as CD-ROMs, DVDs and USB flash-drives.

Floppy disks are random access devices. A thin and flexible plastic disk is coated with iron dioxide and contained in a square plastic case lined with a fabric to remove dust particles when the disk is spinning. Floppy disks are used to transfer small amounts of data between computers, or to backup small files. They are very light and cheap; however, they are low-capacity storage medium, being able to hold mere 1.44 MB of data. Floppy disks are **assigned** to the A: drive.

#### 2. Internal hard disk drives

A hard disk drive (HDD), or hard disk, is an electro-mechanical data storage device that stores

and retrieves digital data using magnetic storage. Hard disks were introduced in 1956 by IBM and since then have been the dominant secondary storage device for general-purpose computers, though today being replaced by solid-state drives or devices (SSDs). HDD is usually called C: drive.

How do they operate?

A typical HDD has the form of a small rectangular box. It consists of a *spindle* that holds **rigid** rapidly rotating disks, called *platters*, which contain the recorded data. The platters are made from a non-magnetic material, usually aluminum **alloy**. They are coated with a shallow layer of ferromagnetic material (chrome dioxide) typically 10-20 nm in depth, with an outer layer of carbon for protection. Magnetic heads, usually arranged on a moving *actuator arm*, are used to record data by magnetizing a thin film of ferromagnetic material on both sides of a disk. Information is written to and read from a platter as it rotates past the read/write heads that are positioned to operate very close to the magnetic surface. Read/write heads ride on a thin film of moving air. The distance between the heads and the platter is called the *flying height*. Sequential changes in the direction of magnetization represent binary data bits, so the data is read from the disk by detecting the **transitions** in magnetization. Data is accessed in a random-access manner, meaning that individual blocks of data can be stored and retrieved in any order.

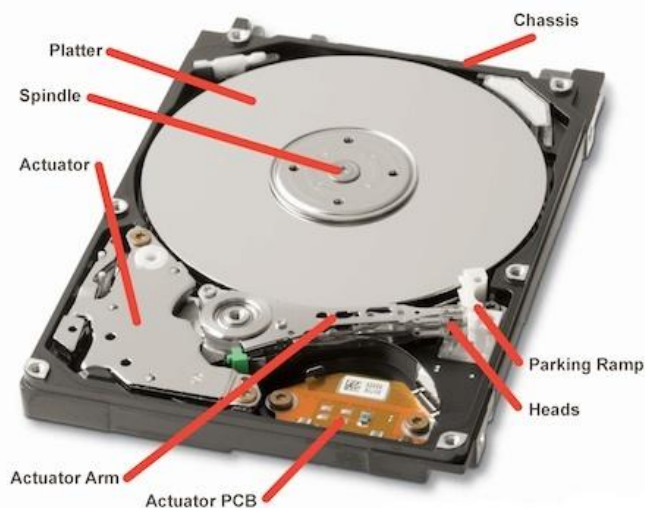

*A hard drive is enclosed in a chassis. The platter is held by a spindle. An actuator moves the heads, which sit at the end of the actuator arm, over the media surface to read and write data. Read/write heads rest at the parking ramp when the hard disk is not operating*

Hard disks are very sensitive to vibrations and shocks, especially when they are operating. A sudden severe motion of the disk can cause a **head crash** – a failure that occurs when a read/write head of a disk makes contact with its rotating platter, permanently damaging its magnetic media. To avoid head crash, never move or hit the computer when the hard drive is spinning.

HDD capacity

A modern HDD can store from 500 GB, which is equivalent to 160,000 photos or 500 hours of video, to 2 TB of data. In 2021, the largest HDD amounted to 18 TB. Modern systems profit enormously from hard drives of large capacities, since partially filled disks fragment less than full disks.

### **3. External hard drives**

External hard drives are removable secondary storage devices used to increase the storage space. Unlike internal hard drives, they are portable and can be used to store files from different devices. They connect to the computer via a USB port. Modern external hard drives have up to 10 TB of memory.

#### 4. Magnetic tapes and drives

Magnetic tape is made of thin magnetizable coating on a long narrow strip of plastic film. It was developed by Fritz Pfleumer in Germany in 1928, and its primary objective was to record voice. Devices that record and playback audio and video using magnetic tape are tape recorders and video tape recorders respectively. A device that stores computer data on magnetic tape is known as a tape drive. Magnetic tape is a sequential-access type, i.e. before getting to a particular point on the tape, all the preceding points must be read through.

How do they operate?

Magnetic tape is usually recorded on one side, the opposite side being a substrate to provide strength and flexibility of the tape. The data is written to and read from the magnetic, or oxide, side by a tape head. The tape runs from the *supply reel* onto the *takeup reel* **wound** by a special motor, passing over tape heads to read, write or erase data. To protect the tape and facilitate handling, the tape is held inside a cartridge.

Magnetic tapes capacity

In 2014, Sony and IBM developed a new vacuum thin-film forming technology able to form extremely *fine crystal particles*. They claimed it was possible to record 148 gigabits per square inch with this new tape media, allowing true tape capacity of 185 TB. December 2020 was marked by another breakthrough. Fujifilm announced that it had created a magnetic storage tape able to store an unbelievable 580 TB of data due to a magnetic particle called Strontium Ferrite (SrFe), which was commonly used as a raw material for making motor magnets. It offers 317 gigabits per square inch in areal density. The capacity of 580 TB is enough to store data equivalent to 120,000 DVDs.



*Modern magnetic tape cartridges look different from conventional cassettes. This Linear Tape-Open (LTO) cartridge consists of a single reel. After the cartridge is inserted, the tape is fed automatically to a reel built into the drive mechanism*

Today magnetic tape is widely used for storing national archives, scientific data, cultural heritage, banking archives, most feature films, etc. *GitHub Arctic Code Vault* is a magnetic storage data **repository** where open source software is preserved for the future generations in the permafrost 250 metres deep beneath a mountain in the Svalbard archipelago on Spitsbergen, Norway. More than 37 million users have contributed to the Arctic World Code Archive, which stores 21 TB of data, including details about software development, programming languages



and other information about computing, which are intended to help the humanity to revitalize computer science and technology in case of global catastrophe. The Arctic World Archive also contains a wide range of historical and cultural data. The vault is accommodated deep enough to avoid damage even from nuclear weapons. The digital film used in the repository is reported to have a lifetime of at least 500 years.

**Answer the questions.**

1. What is data storage in computing?
2. How is data presented so that it becomes machine-readable?
3. Are magnetic storage devices capable of retaining data when the power is switched off?
4. What are the four key components inside the casing of a hard drive? What functions do they perform?
5. What is/was the capacity of your computer's HDD?
6. What are the advantages and disadvantages of magnetic tape storage?

**Задание 2:**

**1) Complete the sentences with the Past Perfect form of the verbs.**

FROM THE HISTORY OF PRINTERS

In 1837, Charles Babbage designed the first mechanical printer, for use with the Difference Engine that he a) \_\_\_\_\_ (develop) in 1822.

In 1953, the first high-speed printer was developed by Remington-Rand, designed to be used with the UNIVAC computer, which b) \_\_\_\_\_ (appear) two years earlier.

Before Shinshu Seiki Co., which later became Epson, developed the first electronic mini-printer in 1968, in 1957 IBM c) \_\_\_\_\_ (introduce) and marketed the first dot-matrix printer.

Gary Starkweather, while working at Xerox, completed the development of the first laser printer by modifying a Xerox model 7000 copier, the production of which d) \_\_\_\_\_ (begin) in 1969.

Inkjet printers did not gain popularity until the mid-1980s, though Hewlett-Packard e) \_\_\_\_\_ (launch) them in 1976.

In 1984, Hewlett-Packard introduced the first thermal inkjet printer, the HP ThinkJet. Earlier the same year, they f) \_\_\_\_\_ (produce) their first laser printer, the HP LaserJet.

When Hewlett-Packard introduced the HP LaserJet in 1984, IBM's high-speed laser printer, 3800 Printing System, g) \_\_\_\_\_ (be) on the market for eight years.

In 1988, Steven Scott Crump developed and patented FDM (fused deposition modelling) – a technology that people h) \_\_\_\_\_ (never know) before.

In 1992, Stratasys, Inc. made available their first 3D printer, based on Scott Crump's (who was the company's co-founder) FDM technology, which the company i) \_\_\_\_\_ (bring) to market a year earlier.

When Scott Crump's patent on FDM expired in 2009, an open-source development community, called *RepRap (Replicating Rapid Prototyper)*, started to use the FDM technology to develop new 3D printers. Dr Adrian Bowyer j) \_\_\_\_\_ (establish) this project at the University of Bath in February 2004, as a way to make FFF 3D printing accessible to everyone.

**2) Complete the sentences with the Past Simple or Past Perfect form of the verbs in brackets.**

1. When I \_\_\_\_\_ (try) to use my laptop, I realized that my battery \_\_\_\_\_ (run) down.
2. I \_\_\_\_\_ (turn) the computer off, but forgot that I \_\_\_\_\_ (not save) my work.
3. I only remembered I \_\_\_\_\_ (not pay) the bill when my Internet connection \_\_\_\_\_ (stop) working.

4. When I \_\_\_\_\_ (receive) the e-mail, I couldn't understand who \_\_\_\_\_ (send) it.
5. When I \_\_\_\_\_ (check) the instructions, I understood what I \_\_\_\_\_ (do).
6. I knew I \_\_\_\_\_ (receive) a virus when I \_\_\_\_\_ (run) the anti-virus program.
7. As soon as I \_\_\_\_\_ (download) the document, I knew I \_\_\_\_\_ (make) a mistake.
8. I could see what \_\_\_\_\_ (go) wrong as soon as I \_\_\_\_\_ (look) inside the printer.
9. I knew I \_\_\_\_\_ (press) the wrong key when nothing \_\_\_\_\_ (happen).
10. When the screen \_\_\_\_\_ (go) blank, I couldn't understand how it \_\_\_\_\_ (happen).

#### 5. Порядок выполнения работы

- 1) изучение лексики, чтение текста, выполнение послетекстовых заданий;
- 2) повторение грамматического материала, выполнение упражнений

#### 6. Содержание отчета

словарный диктант, контроль понимания прочитанного, продуктивная речь по теме с применением новых ЛЕ и глаголов в Past Simple и Past Perfect

## Практическое занятие 9. Оптические устройства хранения

1. **Цель работы:** изучить новую лексику по теме, повторить грамматические конструкции «Условные предложения 2 типа»

2. **Задачи работы:** научиться использовать новые лексические единицы в речи и понимать их в контексте, использовать в речи условные предложения 2 типа

3. **Подготовка к работе:** повторение теоретического материала «Условные предложения 2 типа»

#### Answer the questions.

There is no doubt that virtually everyone has at least several compact disks at home; some have tens or even hundreds. Do you have any? What do they store: video games, music, or other data? Do you ever buy blank compact discs? If you do, what sort of data do you write on them? Do you ever buy movies on DVD or do you prefer watching films online or downloading them from the Internet? How have DVDs changed the film industry?

4. **Задание 1:** прочитать текст и выполнить послетекстовые задания.

### OPTICAL STORAGE

Optical storage is defined as a storage method that uses a laser to write data onto and retrieve data from optical media (discs). Data is deleted, edited, or retrieved from an optical *disc*<sup>2</sup> by inserting the disc into the optical drive. The examples of existing optical media are CDs, DVDs and Blu-ray discs. Among the advantages of optical media are their long lifespan, low cost per bit of storage, high sound quality, and relatively large storage capacity. This makes them ideal for multimedia applications where images, animation and sound need a lot of disc space. In addition, an optical disc is not vulnerable to magnetic fields and is highly durable, so it can be transported through airport metal detectors without damaging data. In case of electric surge, the data is not lost as a disc does not have any electric circuitry. Should it get stuck in the drive, the user can recover it from the computer using the emergency **ejection** pinhole.

#### Types of Optical Media

##### 1. CDs (Compact Discs)

The compact disc is a digital optical disc data storage format that was co-developed by Philips and Sony to store and play digital audio recordings. It was released in 1982 branded as *Digital*

---

<sup>2</sup> Magnetic storage media are referred to as disks, while optical media are discs.

*Audio Compact Disc.* CDs are designed to hold up to 74 minutes of uncompressed stereo digital audio or about 650 MB of data.

Standard CDs have a diameter of 120 mm and are 1.2 mm thick. A CD is made from polycarbonate plastic and weighs 14-33 grams. In the centre there is a spindle hole (15 mm in diameter). The disc itself is made up of several layers as shown in the picture below.

How do CDs operate?

CD data is represented as tiny **indentations** (hollows) known as *pits*, etched by the laser in a spiral track on the polycarbonate layer. The flat areas between pits are known as *lands*. Each pit is approximately 100 nm deep by 500 nm wide, and varies from 850 nm to 3.5  $\mu\text{m}$  in length, so a track of pits may contain about 3 billion pits precisely arranged on a spiral. The distance or spacing between the tracks (the *pitch*) is 1.6  $\mu\text{m}$ . If the track could be unspiralled, it would be about 3.5 miles (around 5633 km) long.

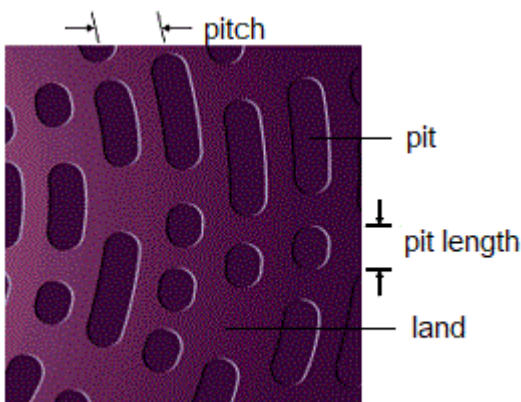

*The pits in a CD are 500 nm wide, 830 -3000 nm long and 150 nm deep*

A disc is read by focusing a 780 nm wavelength semiconductor laser through the bottom of the polycarbonate layer. Due to the change in height between pits and lands the light is reflected differently. Because the pits are **indented** into the top layer of the disc and are read through the transparent polycarbonate base, the pits form *bumps* when read. Actually, bumps dissipate or absorb the incident laser beam, while lands reflect it. When an audio CD is being played, the disc is spinning at approximately 500 RPM at the inside of the disc, and approximately 200 RPM at the outside edge. The track on a CD begins around the spindle hole and spirals outwards. Since each outer track revolution contains more pits than each inner track revolution, the CD must be slowed down as it plays in order to maintain a constant rate of data.

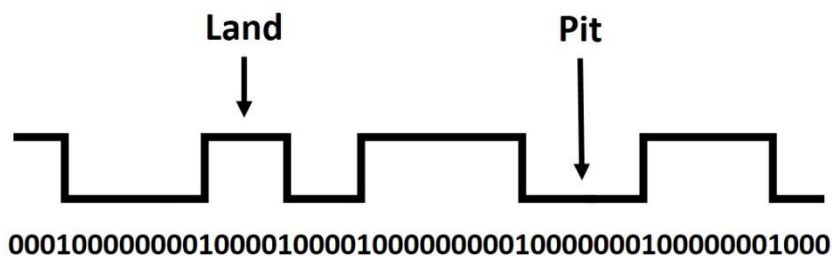

*Lands and pits*

The pits and lands *do not* directly represent the 0s and 1s of binary data. Instead, **non-return-to-zero (NRZ)<sup>2</sup>** encoding is used: a transition from either pit to land or land to pit indicates a 1, while no change indicates a series of 0s. These encoding techniques were originally designed



for CD Digital Audio, but they later became a standard for almost all CD formats (such as CD-ROM).

<sup>2</sup> In telecommunication, it is a binary code in which ones are represented by one significant condition, usually a positive voltage, while zeros are represented by some other significant condition, usually a negative voltage.

## 2. DVDs (Digital Video Discs or Digital Versatile Discs)

Invented and developed in 1995 and released in late 1996, DVDs were readily adopted by movie and home entertainment distributors to replace the ubiquitous VHS tape as the primary consumer video distribution format. Today DVDs have multiple applications which include personal and professional video production, backup, archiving, radio and television broadcast storage and many other. The massive advantage of a DVD is that they do not require the use of the Internet for home entertainment. The medium can store any kind of digital data and is widely used for software and other computer files as well as video programs watched using DVD players or DVD drives.

While having the same dimensions as a CD, a DVD offers higher storage capacity. The pitch between tracks on a DVD is smaller, so the tracks are closer to each other than on a CD, which allows for more tracks. The pits are also tinier, so there are more pits per track. As a result, the DVD specification provides a storage capacity of 4.7 GB for single-layer DVDs, while dual-layered can hold 8.5 GB. This can be doubled to 9.4 GB and 17 GB by making the DVDs double-sided, with readable surfaces on both sides of the disc.

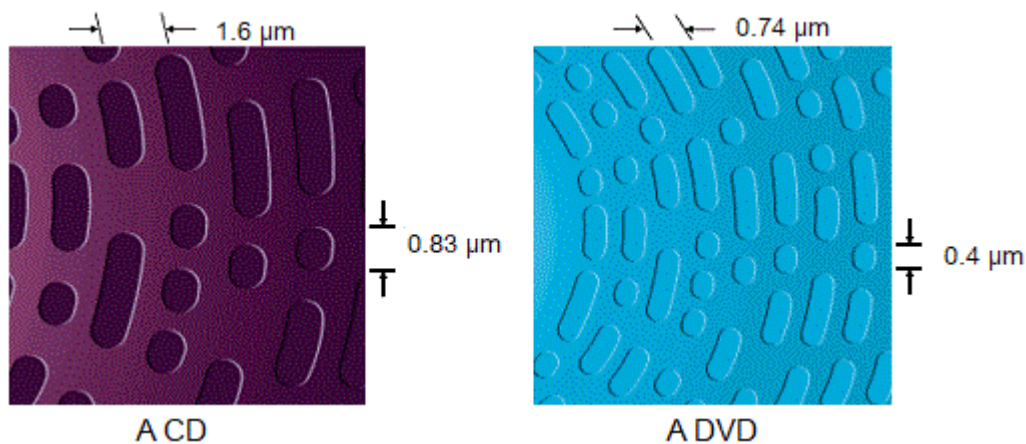

*The areal density of the two optical storage formats, CD and DVD, compared*

How do DVDs operate?

DVD uses a 650 nm red laser to record data. The minimum speed at which data on a DVD can be written is 1.385 MB per second. This rate can increase depending on the model of DVD drive and the properties of the disc and is marked 2×, 4×, etc. The technique of writing data onto DVDs is same as that for CDs. To write or read data on a dual-layer DVD, a DVD burner drive's hardware accesses the additional layer by refocusing the laser through a normally-placed, semitransparent first layer. The part of a disc that has been recorded is visually different from the blank portion.

### 3. HD DVD and Blu-ray discs

The second half of 2000s was marked by the so called “format war” between two competing formats of high-definition discs, Toshiba’s HD DVD and Sony’s Blu-ray disc. Both of them were intended to **supersede** the DVD format in terms of definition and capacity.

#### *HD DVD*

*High Definition Digital Versatile Disc (HD DVD)* is a **discontinued** type of DVD, the production of which was **abandoned** in 2008 after the “format war” of 2006-2008, won by *Blu-Ray disc*. HD DVD could store about 3.2 times as much data per layer as a conventional DVD (maximum capacity: 15 GB per layer compared to 4.7 GB per layer, with a dual-layer capacity of 30 GB). A number of world-famous box-office hits such as *The Last Samurai*, *The Phantom of the Opera* and *Pan’s Labyrinth* were released on HD DVD to be played on dedicated HD DVD players manufactured by Toshiba. The failure of Toshiba’s HD DVD had nothing to do with technical specifications of the format. The major reason was that Sony succeeded in persuading Warner Brothers to release high-definition editions of movies on Blu-ray exclusively. Netflix and Paramount Pictures followed Warner Brothers, which put an end to HD DVDs. Toshiba lost an estimated \$1 billion due to this defeat.

#### *Blu-ray disc*

The name “Blu-ray” refers to the blue laser (which is actually a 405 nm violet laser) used to read the disc. The letter “e” was deliberately excluded from the word “blue” to register the trademark (the name “Blue ray” could not be patented). The shorter wavelength can be focused to a smaller area on a disc, therefore it is possible to create pits that are less than half the size of those on a DVD (0.15  $\mu\text{m}$  instead of 0.4  $\mu\text{m}$ ). Consequently, the pits can be spaced more closely, resulting in a shorter track pitch (0.32  $\mu\text{m}$  instead of 0.74  $\mu\text{m}$ ), and enabling a Blu-ray disc to store information at a greater density than with the longer-wavelength red laser used for DVDs. As a result, a Blu-ray disc can hold about five times the amount of data that can be stored on a DVD, though Blu-rays are the same size as DVDs. Conventional Blu-ray discs contain 25 GB per layer, with dual-layer discs (50 GB) being the industry standard for **feature-length** video discs. Also, triple-layer discs (100 GB) and quadruple-layer discs (128 GB) are available. High-definition video may be stored on Blu-ray discs with up to 1920  $\times$  1080 pixel resolution, while DVD-Video discs were limited to a maximum resolution of 720  $\times$  480 pixels or 720  $\times$  576 pixels depending on the television standard. The minimum speed at which a Blu-ray Disc can be written is 36 Mb (4.5 MB) per second.



*The Blu-ray logo was introduced in 2006 and has not been changed since then. The colour palette of blue on white is most commonly used. For official documents, the combination of black on white is used*

Commercial manufacturing of Blu-ray discs started in 2006. Among the first Blu-ray disc titles

were *The Fifth Element*, *House of Flying Daggers* and *The Terminator*.

The main application of Blu-ray is as a medium for video material such as feature films and for the physical distribution of video games for the PlayStation 3, PlayStation 4, PlayStation 5, Xbox One, and Xbox Series X.

In 2015, Ultra HD Blu-ray was introduced, which can hold up to 50, 66 and 100 GB of data at a speed of 92 to 144 MB/s.

#### Latest Types of Optical Discs

In 2015 Sony and Panasonic introduced the **Archival Disk (AD)**, designed with a capacity of 300 GB to 1 TB per disc. The companies claim that it is resistant to environmental changes and allows compatibility with different formats to extend the lifespan of the disc up to 50 years. It is intended to be used for professional handling of big data.

Another more ambitious form of optical storage yet to achieve commercial success is **holographic data storage (HDS)**, the development of which was started by The IBM in the 2000s. This type is also known as **3D data storage**, and it relates to storing information by making holographic images. In optics, holography creates photographic images using light instead of a lens, utilizing a laser beam to project the representation of the subject. Holographic data storage records information throughout the volume of the medium and is capable of recording multiple images in the same area utilizing light at different angles. Sample discs use similar read mechanisms as those found on Blu-ray players.

In 2016, scientists at the University of Southampton developed the first-ever **5D optical data storage disc** or **glass disc**, also known as **Superman Memory Crystal**. Using nanostructured glass, it records and retrieves digital data by laser writing that takes one quadrillionth of a second. The disc can store up to 360 TB, and it also withstands thermal stability up to 1000 degrees and an unlimited lifetime at room temperature, meaning that its lifespan is almost eternal (billions of years). Since it is a stable form of portable memory, it is most suitable for extensive archives from corporations and organizations, such as national archives, museums, libraries, essential documents, and records requiring long-term preservation (“Eternal 5D Storage”). As of 2018, the production of the glass disc was acquired by the *Arch Mission Foundation*, a non-profit organization whose mission is to archive and preserve vital information about humanity (“to backup planet Earth”) in compact forms to spread it on the Solar System. Two of the first discs produced were given to Elon Musk, the owner of Tesla, and one of the discs is currently orbiting the Earth in his private Tesla Roadster.

**Match the statements with the correct type of optical disc: 1 – CD, 2 – DVD, 3 – HD DVD, 4 – Blu-ray.**

1. It has the largest pit length of all types of optical media.
2. It lost the battle with its competitor due to poorer marketing.
3. It is a popular medium for distributing video games.
4. Among the first feature films distributed on this medium was a famous movie starring Bruce Willis and Milla Jovovich.
5. It has the highest areal density among all types of optical media.

6. Two companies worked together to design it.

**Задание 2:** выполнить грамматические упражнения.

**1) Complete the second conditional sentences using the correct form of the verbs. Use contracted forms. Do not use might/could in main clauses.**

1. If our website \_\_\_\_\_ (crash), we would lose a lot of consumers.
2. If the computer mouse didn't exist, it \_\_\_\_\_ (be) far more complicated to interact with the computer.
3. What smartphone \_\_\_\_\_ you \_\_\_\_\_ (choose) if the money weren't important?
4. If the internet connection \_\_\_\_\_ (not be) stable, our videoconference wouldn't be possible.
5. If we \_\_\_\_\_ (not have) a GPS, we could get lost.
6. If we \_\_\_\_\_ (be) a big company, we \_\_\_\_\_ (buy) an expensive videoconferencing system.
7. If we \_\_\_\_\_ (not have) such a vast client database, we \_\_\_\_\_ (not need) a large storage.
8. I \_\_\_\_\_ (install) this software if it \_\_\_\_\_ (be) a freeware.
9. If my hard drive \_\_\_\_\_ (have) more capacity, I \_\_\_\_\_ (not have) to defrag it.
10. If I \_\_\_\_\_ (can) afford it, I \_\_\_\_\_ (buy) a really expensive gaming computer.

**2) Use the prompts to write second conditional sentences as in the example. You can use either full or contracted forms. Where appropriate, use might/could in main clauses.**

0. you format your full HDD – you lose your data forever → *If you formatted your full HDD, you would/could lose your data forever.*

1. hard drives are not quite reliable – they are not popular today
2. you shake the tower while the computer is operating – the mechanical shock causes head crash
3. every person on Earth can complete one calculation per second – it takes the world population 305 days to do what the supercomputer can do in one second
4. it's impossible to divide a hard drive into several partitions – we have to store the operating system and data files on one partition, which is not safe from malware attacks
5. the computer mouse doesn't exist – the interaction with the computer is slower and more complicated
6. magnetic tape storage isn't durable – the Arctic World Archive repository doesn't rely on this type of storage
7. the Arctic World Archive isn't accommodated deep enough – it isn't supposed to avoid damage from nuclear weapons
8. you decide to buy a licenced version of the software plus annual upgrade – our company can work out a special price for you

9. you are our long-term customers – we may consider a discount

10. modern tapes don't have sufficient areal density – they aren't able to provide considerable storage capacity

#### 5. Порядок выполнения работы

- 1) изучение лексики, чтение текста, выполнение послетекстовых заданий;
- 2) повторение грамматического материала, выполнение упражнений

#### 6. Содержание отчета

словарный диктант, контроль понимания прочитанного, продуктивная речь по теме с применением новых ЛЕ и условных предложений второго типа

## Практическое занятие 10. Флеш-память

1. **Цель работы:** изучить новую лексику по теме, изучить употребление слов-связок linking words

2. **Задачи работы:** научиться использовать новые лексические единицы в речи и понимать их в контексте, правильно употреблять слова-связки

3. **Подготовка к работе:** изучение теоретического материала (linking words) и новых ЛЕ

4. **Задание 1:** прочитать текст и выполнить послетекстовые задания.

### FLASH MEMORY

Flash memory is an electronic non-volatile computer memory storage medium that can be electrically erased and reprogrammed. Data is erased in units called **blocks** and rewritten at the byte level. Flash memory today has become ubiquitous: it is found in USB flash drives, digital multimedia players, laptops, mobile phones, video game cards, digital cameras, network switches, solid-state drives, scientific instrumentation, industrial robotics, and medical electronics.

Flash memory was developed by Dr. Fujio Masuoka, an inventor and mid-level factory manager, at Toshiba Corporation in 1980. Masuoka's objective was to create a memory chip which could preserve data when the power was turned off. Flash memory was named after its capability to erase a block of data "in a flash", i.e. very quickly, just like a camera flash in photography illuminates the scene. Toshiba began marketing flash memory in 1987.

Flash memory is based on EEPROM technology and is its distinct type. While EPROMs have to be erased completely before they can be rewritten, flash memory can be erased and rewritten in blocks, which are usually much smaller than the entire device. Also, EEPROM only allows for erasing data byte by byte, whereas flash memory can erase an entire **chunk**, or "sector" of memory at a time, which makes it faster. EEPROM is used for small amounts of data, but flash memory can hold large amounts of data.

How does flash memory work?

Flash memory stores information in an array of memory cells made from **floating-gate transistors**. Each cell usually stores one bit of data (1=erased and 0=programmed). However, there are multi-level cell (MLC) devices which can store more than one bit per cell. The flash chip's cells are arranged in a grid that has a transistor at each intersection. Each transistor has two gates: a floating gate and a control gate. The gates are separated from each other by a thin dielectric material (the oxide layer). Flash memory works by adding or removing electrons to and from the floating gate. When electrons are present on the floating gate, the electric current cannot flow through the transistor, and the bit state is 0 (a bit is programmed). When electrons

are discharged from the floating gate, current is allowed to flow and the bit state is 1 (erased). Flash memory uses a mechanism called *Fowler-Nordheim tunnelling* to program and erase flash memory cells, as the two following pictures show.

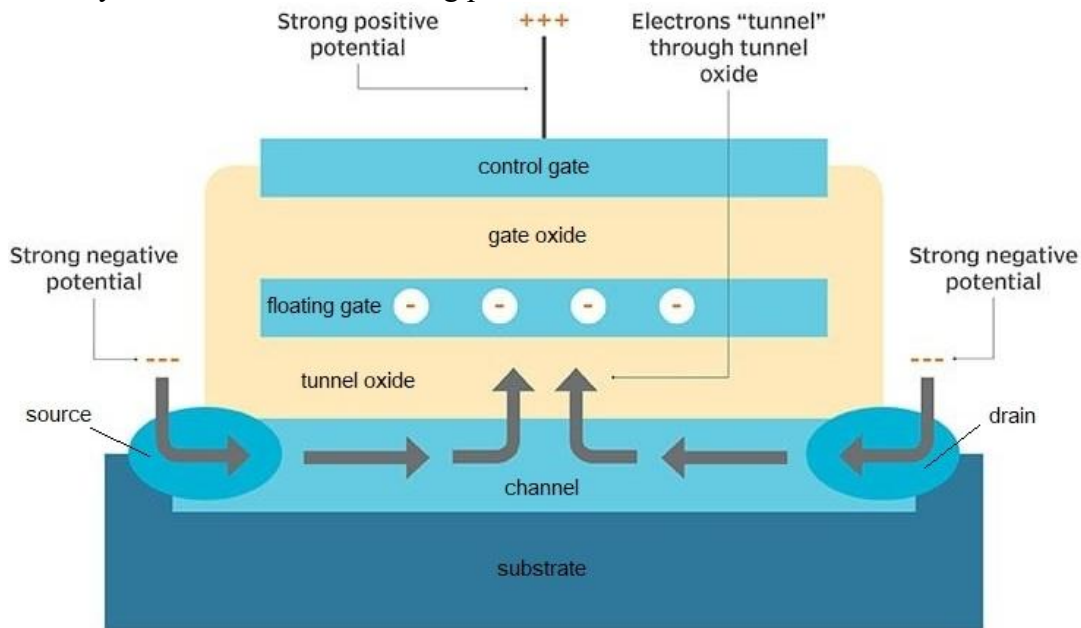

*Programming a bit in a floating-gate flash memory cell. A strong electric field between the negatively charged source and the positively charged control gate draws electrons into the floating gate.*

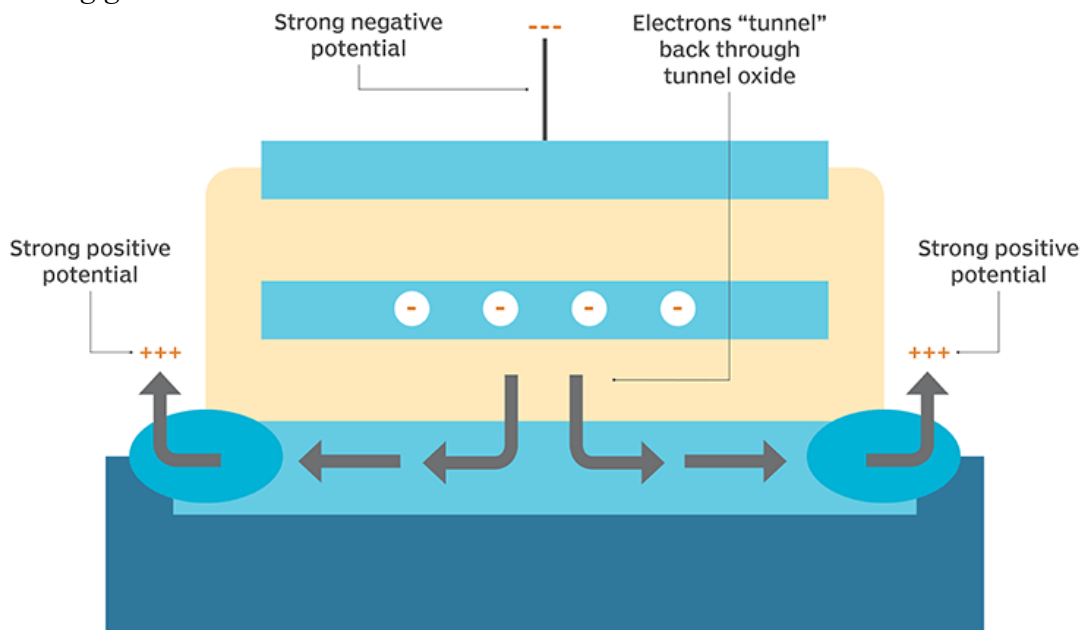

*Erasing a bit in a floating-gate flash memory cell. A strong negative charge on the control gate forces electrons through the oxide layer into the channel where they are drawn to the strong positive charge at the source and the drain*

Since the floating gate is surrounded by the oxide layer which electrically isolates it, the electrons placed on the floating gate are trapped on it, which makes flash memory non-volatile.

#### Flash Memory Devices

Flash memory has become the dominant memory type for writing and storing large amounts of data. As an internal storage, it can be found in hard drives (for storing firmware), *DSL (Digital Subscriber Line)* modems, and wireless network devices.

The main removable flash memory devices are flash memory cards, USB flash-drives and SSDs (solid-state drives).



## 1. Flash memory cards

A flash memory card is a small (stamp-size) storage device usually used on digital cameras, video-game consoles, smartphones, tablets, etc. Flash memory cards can store text, pictures, audio and video. (N.B.: do not confuse SIM (Subscriber Identity Module) card which uses ROM to hold the card's data used to identify the subscriber on the network and EEPROM to store the messages and phone book contacts, with an SD card used for the user's data storage, e.g. photos and music.)

Advantages and disadvantages of flash memory cards

Among the advantages of flash memory cards are low energy consumption, extreme portability and mechanical shock resistance. The main disadvantage is the problem of compatibility. However, this limitation can be solved by using flash card readers.

Flash memory cards are *not* designed for long-term storage, as their primary function is to hold data temporarily. Data should be transferred from a flash memory card to a computer as soon as possible. However, the manufacturers promise up to 10 years of data **integrity** provided the card is stored under favourable conditions, without being exposed to dust, moisture, or extreme temperatures.

## 2. USB flash drives

A USB flash drive is a data storage device that includes flash memory with an integrated USB interface. It is removable, rewritable and quite small, which makes it an extremely convenient portable storage device. USB flash drives are sometimes called “memory sticks”, but this name is a **proprietary** trademark of Sony, while “USB flash drive” is a generic name for all devices of this type.

The USB flash drive is supposed to have been invented in 1999 in Israel. However, when in late 2000 a Singaporean company named *Trek 2000 International* sold first USB flash drives, it claimed that it was the original inventor of the device. Since first appearing on the market, storage capacities of USB flash drives have risen while prices have dropped, and this trend continues.



*USB flash drives can come in many unexpected designs*

What is inside a USB flash drive?

A USB flash drive is made up of a small printed circuit board, which has some power circuitry and a small number of surface-mounted integrated circuits contained in a plastic casing. One of the integrated circuits provides an interface between the USB connector and the onboard memory, while the other is the flash memory. One end of the device is fitted with a single Standard-A USB plug. Some flash drives additionally offer a micro USB plug, facilitating data transfer between different devices. The cover is typically made of plastic or metal, protecting the electronics against mechanical stress and even possible *short circuits*.

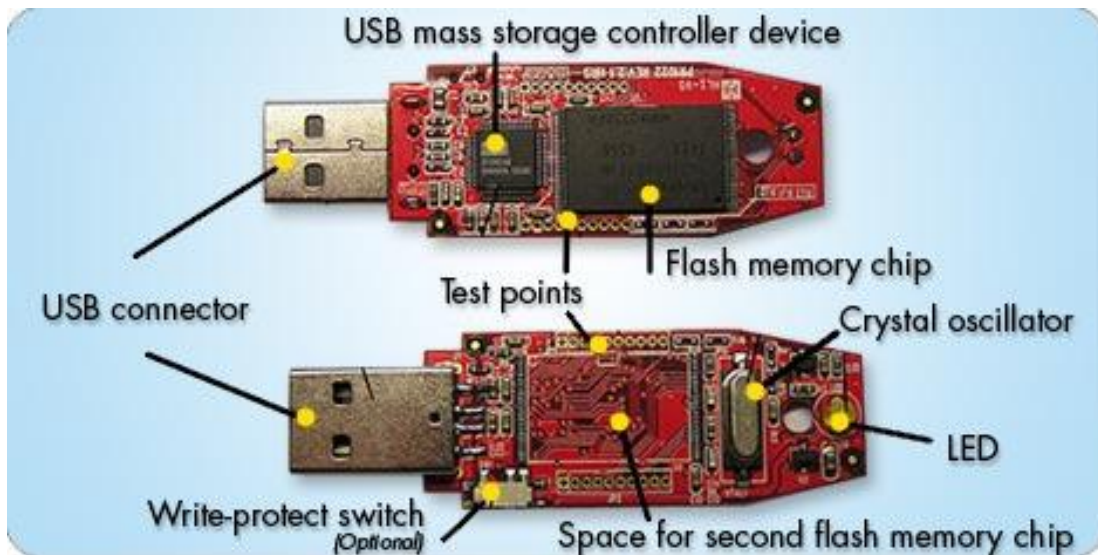

### *Inside a USB flash drive*

A *USB connector* allows connection with a port on a personal computer and provides power supply to the flash drive from the computer. A *flash controller* with a small amount of ROM and RAM manages data stored on flash memory and communicates with the host hardware. *Test points* are used to test the USB during the manufacturing process. A *NAND flash memory chip* holds the data. A *crystal oscillator* creates an electrical signal with a constant frequency to provide a stable 12 MHz clock signal for the digital integrated circuits and controls the device's data output. *LED light* indicates that the device is connected to the port properly and is working. A *write-protect switch* keeps the contents of the drive from malware when the user needs to view them on a public computer. The **unpopulated space for a secondary memory chip** allows the manufacturer to install an additional memory chip on a single printed circuit board. Some drives may offer expandable storage via an internal memory card slot, like that of a memory card reader.

### Advantages and disadvantages of flash drives

High data transfer speed is among the primary strong points of flash-drives. Since USB drives do not require any form of internet connection, they have relatively high data transfer rates. Price is another main advantage. Compared to other external storage devices, USB drives are quite inexpensive and affordable. Flash drives are not vulnerable to data loss occurring from accidental scratches, dust or exposure to magnetic fields. USB drives are small and light and thus are highly portable. They are compatible with any device fitted with a USB port. However, a USB drive can be easily infected if the device it is used with is not malware-free. Also, the physical size of a flash drive may be the reason for its loss, which can compromise your confidential data. Therefore, it is unreasonable to store sensitive data on a flash drive.

### **3. Solid state drives (SSDs)**

A solid-state drive is a solid-state storage device that uses flash-based memory to store data persistently and functions as secondary storage in the hierarchy of computer storage. Solid state drives are sometimes called solid-state devices or solid-state disks, even though SSDs do not have the physical spinning disks and movable read-write heads used in HDDs.

### Specifications

As for 2021, computer SSDs are available in up to 4 TB capacity and cost around \$100 per TB. The largest enterprise solid-state drive, Samsung's PM1643a, has a capacity of 30.72 TB (the 50 TB and 100 TB variants of Nimbus' Data ExaDrive cannot be considered commercially available). Typical SSDs have seek time between 0.06 and 0.16 ms. The read speed is up to 5



GB per second and the write speed can be up to 4.4 GB per second. SSDs can be Single Level Cell (SLC), Multi Level Cell (MLC) and Triple Level Cell (TLC). The expected lifespan is around 10 years.

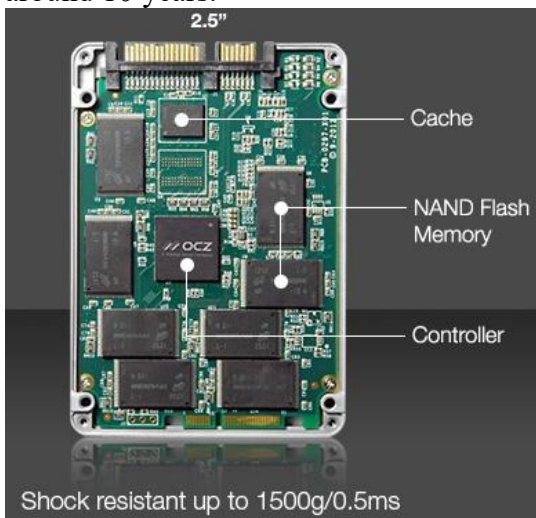

#### *A solid-state drive inside and outside*

#### Advantages and disadvantages of SSDs

A key disadvantage of SSDs is that they can endure only a relatively small number of write cycles, 3000 for MLC and 1000 for TLC. Though SLC-drives can survive a projected 10,000 write cycles, they are not usually intended for general-purpose computers and are used in high-end servers. The strong points of solid-state drives are their being energy-efficient, small, light and noiseless. Also, SSDs do not need defragmentation. Another huge SSD advantage is durability. Since they have no moving parts, solid-state drives aren't **susceptible to** damage or degraded performance from vibrations or movement. All in all, a solid-state drive can create an extremely **responsive** system, with lightning-fast boot times, application launch times, and file-transfer speeds.

#### **4. Hybrid hard drives**

Hybrid hard drives **blend** HDD high capacity with SSD speeds by placing traditional rotating platters and a small amount of high-speed flash memory on a single drive. The solid-state drive in a hybrid drive acts as a cache for the data stored on the hard disk drive, providing high-speed access to the copies of the most frequently used data kept in a faster NAND flash memory.

#### Advantages and disadvantages of SSHDs

Hybrid drives tend to cost slightly more than traditional hard drives, but far less than solid-state drives. Other advantages of hybrid storage products include capacity and manageability. The operating system of your computer will generally recognize a hybrid hard drive as either an SSD or HDD. However, if any part of a hybrid drive stops working, the entire device will stop functioning. Additionally, if data on a hybrid hard drive is lost, it is much more complicated to recover it. Both of the SSHD components should work properly in order to have a better chance of recovering the data. Still, a hybrid drive can be a great option to improve system performance.

#### **Answer the questions.**

1. How did flash memory get its name?
2. What type of computer memory does flash memory originate from?
3. What is the role of floating-gate transistors in terms of programming and erasing flash memory cells?
4. When does a cell become programmed? When does it become erased?
5. Why are some USB flash drives fitted with LED light?
6. What is the function of a write-protect switch on a USB flash drive?
7. What are the advantages of SSDs over HDDs? What is the main weak point of SSDs?

8. Why can a hybrid hard drive be considered a great option to enhance the system performance?

**Label the parts of a USB flash drive.**

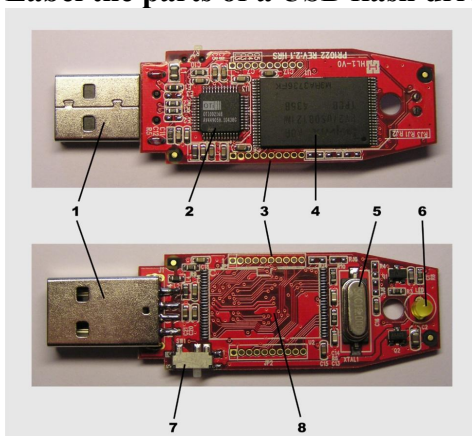

**Задание 2:** выполнить грамматические упражнения.

**Complete the gaps with the appropriate linkers from the box.**

a) At the beginning of the 1970s, there were essentially two types of computers. There were room-sized mainframes, costing hundreds of thousands of dollars, which were built one at a time by companies such as IBM and CDC. \_\_\_\_\_, there were smaller, cheaper, mass-produced minicomputers, costing tens of thousands of dollars, that were built by a handful of companies, such as Digital Equipment Corporation and Hewlett-Packard Company, for scientific laboratories and businesses.

\_\_\_\_\_, most people had no direct contact with either type of computer. The idea that anyone would have his or her own desktop computer was generally regarded as **far-fetched**\*. \_\_\_\_\_, with advances in integrated circuit technology, the necessary building blocks for desktop computing began to emerge in the early 1970s.

still    nevertheless    also

\* unlikely, unconvincing

b) Using obsolete systems create great risks: for example, few people are trained in the languages used to program and run such technology, \_\_\_\_\_ it could be problematic to fix software when needed – their manufacturers may even have long gone out of business. \_\_\_\_\_, many hardware parts used within these systems are unsupported, and it may be difficult and expensive to find replacement if they break down. \_\_\_\_\_, severe technological limitations have an **adverse**\* effect on the performance. \_\_\_\_\_, companies that are supposed to be at the cutting edge of the advanced science should be the first ones to implement latest scientific developments; otherwise, their reputation would be compromised.

besides    so    moreover    furthermore

\* harmful, unfavourable; preventing success or development

c) 1. \_\_\_\_\_ CDs and DVDs are similar in size and shape, they are very different in internal structure and data capacity.

2. Today a good DVD drive shouldn't cost more than \$40. \_\_\_\_\_, a good Blu-ray drive should cost around \$100.

3. In a DVD, the tracks are very close together, \_\_\_\_\_ allowing more tracks than in a CD.

4. Blu-ray defeated HD DVD in the “format war”. \_\_\_\_\_, Toshiba lost an enormous \$1000000000. \_\_\_\_\_ DVDs rely on a red laser, this format uses a blue-violet laser, \_\_\_\_\_ the name Blu-ray.

however while consequently hence though thus

#### 5. Порядок выполнения работы

- 1) изучение лексики, чтение текста, выполнение послетекстовых заданий;
- 2) повторение грамматического материала, выполнение упражнений

#### 6. Содержание отчета

словарный диктант, контроль понимания прочитанного, продуктивная речь по теме с применением новых ЛЕ и умение составлять предложения с использованием слов-связок

## Практическое занятие 11. Введение в программное обеспечение

1. **Цель работы:** изучить новую лексику по теме, изучить грамматические конструкции Present Perfect Passive

2. **Задачи работы:** научиться использовать новые лексические единицы в речи и понимать их в контексте, строить предложения с использованием Present Perfect Passive

3. **Подготовка к работе:** изучение теоретического материала Present Perfect Passive

4. **Задание 1:** прочитать текст и выполнить послетекстовые задания.

### Introduction into Computer Software

Computer software is anything that can be stored electronically. The term is used to contrast with computer hardware (the physical objects); unlike hardware, software cannot be touched. Hardware and software require each other and neither has any value without the other.

**Firmware** is software that has been permanently stored in hardware. It is typically not user accessible and usually contains the basic software programming of the device. Firmware such as the **BIOS** (Basic Input/Output System) of a personal computer typically contains only elementary basic functions and allows the computer to run more complicated software.

Software refers to the computer programs and data held in the storage of the computer. In other words, software is a set of programs, procedures, algorithms and its documentation concerned with the operation of a data processing system. On most computer platforms, software can be grouped into two broad categories:

**System software** is the basic software needed for a computer to operate (most notably the **Operating System**) including: DOS, Windows, UNIX, Linux, Mac OS, etc.

**Application software** is all the software that uses the computer system to perform useful work beyond the operation of the computer itself. Examples of common applications are: word processor, spreadsheet, database, Internet browser, email, games, etc. **Data** is all the documents and files that are created or manipulated by application software, including documents, spreadsheets, pictures, movies, etc.

### System Software: Operating Systems

All computers need some sort of Operating System (**OS**) to function. The majority of modern home computers use some form of Microsoft’s operating systems (Apple computers made up only 13.5% of new home computer sales in 2012).

The original Microsoft operating system was called **DOS** (Disk Operating System) and was replaced by a mouse controlled Graphical User Interface (GUI) that Microsoft called **Windows**. Windows comes in various versions beginning with version 3.x then 95, 98, ME, XP, Vista, 7 and 8. Apple’s Mac computers use their own operating system beginning with Apple **OS 1** though to OS X 10.8 and are commonly referred to by cat names including Tiger, Leopard, Snow

Leopard, Lion and Mountain Lion. **Linux** is a free operating system that has many of the functions of Windows or Apple OS.

The operating system controls the flow of information to and from the CPU. Basically the computer starts from scratch every time you turn the power on and it first needs to load the operating system (**booting up**). It automatically checks all its components and then loads into the operating system. Once the operating system is loaded the user can start an application or program. Application software is created to work on specific operating systems only.

### **Application Software**

There are millions of different pieces of application software available for almost every conceivable need. The four basic types of applications are:

1. **Commercial** software comes prepackaged and is available for purchase from software stores and through the Internet.
2. **Shareware** is software developed by individual and small companies that cannot afford to market their software worldwide or by a company that wants to release a demonstration version of their commercial product. You will typically have an evaluation period in which you can decide whether to purchase the product or not. Shareware software often is disabled in some way and has a notice attached to explain the legal requirements for using the product.
3. **Open Source** software is created by a collaboration of programmers working together. Open source programs are often open for anyone to contribute to and the end products of open source projects are commonly released for public use. Open Source software is not public domain in that the company or individual that develops the software retains ownership of the program but the software can be used freely. Many popular Open Source applications are being developed and upgraded regularly by individuals and companies that believe in the Open Source concept. There is usually a copyright notice that must remain with the software product and is similar to freeware.
4. **Freeware** is created by generous programmers and developers and released is distributed freely, usually accompanied a copyright notice and terms of service that must remain with the software product. Freeware is generally free for anyone to use and distribute so long as the copyright notice and terms of service remain with the software.

### **Software Learning Check: True or False?**

1. A major difference between hardware and software is that you can touch hardware.
2. The computer's BIOS must run in order for the operating system to function properly.
3. Application software is written to work on a specific operating system.
4. Computers basically function by accepting input, storing that input and proving output.
5. Microsoft Windows is a type of computer BIOS.
6. Microsoft Windows 8 and Apple Mountain Lion are basically the same thing.
7. You must buy commercial software in order to have a good working and fully featured word processor or spreadsheet program.
8. The operating system must be running in order to start a software application.
9. You can install Windows system software on a modern Apple Macintosh computer.
10. Most hardware peripherals such as printers and DVD drives contain firmware.

**Задание 2:** выполнить грамматические упражнения.

**1) The MacroSoft Corporation has moved to a new office space. The MacroSoft employees have just started to unpack. They have already done a lot, but it doesn't seem that everything is ready for them to start work after the relocation. Write sentences using Present Perfect Passive, as in the example.**

Example: The Public Relations manager **has sent** a change address notice to the clients. → *A change address notice **has been sent** to the clients.*

1. The workers have arranged the furniture, but they haven't set workplace lighting yet.

2. The courier service has delivered the new computers.
3. The workers have unpacked the PCs, but they haven't mounted them on the desks yet.
4. The managers of Purchase Department have ordered new software, but the vendor hasn't supplied it yet.
5. The IT department have chosen an ISP, but they haven't signed a contract yet.
6. The female employees have already put the pot flowers on the window sills, but they haven't fed Mac the cat, the mascot of the company.

**2) Ask questions in Present Perfect Passive as given in the examples.**

Example 1: Some improvements have been proposed to the developers. (What) → *What improvements **have been proposed** to the developers?*

Example 2: Some improvements have been proposed to the developers. (Who) → *Who **have** the improvements **been proposed** to?*

1. The password has been handed over to the hackers. (Why)
2. New monitors have been purchased by the company. (How many)
3. The new monitors haven't been delivered yet. (Why)
4. 16:9 aspect ratio monitors have been used since late 2000s. (Since what time)
5. OLED monitors have been produced since 2007. (How long)
6. LCDs have been known since the 1960s. (How long)
7. A lot of spam e-mails have been received by the company recently. (What sort of)
8. We haven't received the invoice. Perhaps, it has been sent to a wrong address. (Where ... to)
9. The reports haven't been typed yet. (Why)
10. The results of the test have been announced. (Who ...to)

**5. Порядок выполнения работы**

- 1) изучение лексики, чтение текста, выполнение послетекстовых заданий;
- 2) повторение грамматического материала, выполнение упражнений

**6. Содержание отчета**

словарный диктант, контроль понимания прочитанного, продуктивная речь по теме с применением новых ЛЕ и глаголов в страдательном залоге Present Perfect

## Практическое занятие 12. Типы операционных систем

1. **Цель работы:** изучить новую лексику по теме, повторить грамматические конструкции "Warnings and Recommendations"
2. **Задачи работы:** научиться использовать новые лексические единицы в речи и понимать их в контексте, строить предложения с использованием грамматических
3. **Подготовка к работе:** повторение теоретического материала
4. **Задание 1:** прочитать текст и выполнить послетекстовые задания.

### Types of Operating System

An operating system is a set of programs that enables a user to operate and interact with a computer. Examples of operating systems are Linux distributions, Windows, Mac OS, FreeBSD, etc. There are many types of operating systems.



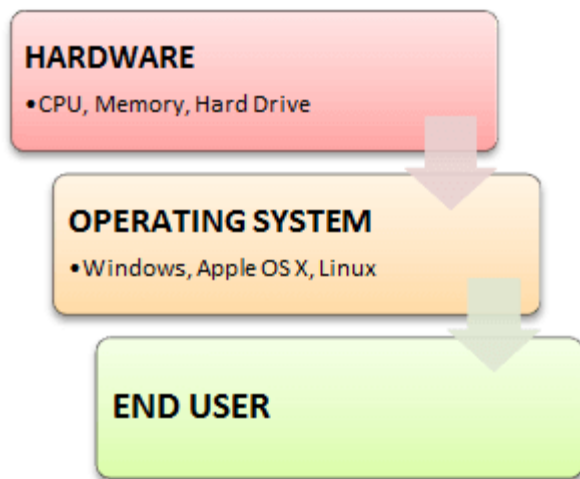

Following are the popular types of OS (Operating System):

- Batch Operating System
- Multitasking/Time Sharing OS
- Multiprocessing OS
- Real Time OS
- Distributed OS
- Network OS
- Mobile OS

#### **Batch Operating System**

Some computer processes are very lengthy and time-consuming. To speed the same process, a job with a similar type of needs are batched together and run as a group.

The user of a batch operating system never directly interacts with the computer. In this type of OS, every user prepares his or her job on an offline device like a punch card and submit it to the computer operator.

#### **Multi-Tasking/Time-sharing Operating systems**

Time-sharing operating system enables people located at a different terminal (shell) to use a single computer system at the same time. The processor time (CPU) which is shared among multiple users is termed as time sharing.

#### **Real time OS**

A real time operating system time interval to process and respond to inputs is very small. Examples: Military Software Systems, Space Software Systems are the Real time OS example.

#### **Distributed Operating System**

Distributed systems use many processors located in different machines to provide very fast computation to its users.

#### **Network Operating System**

Network Operating System runs on a server. It provides the capability to serve to manage data, user, groups, security, application, and other networking functions.

#### **Mobile OS**

Mobile operating systems are those OS which is especially that are designed to power smartphones, tablets, and wearables devices.

Some most famous mobile operating systems are Android and iOS, but others include BlackBerry, Web, and watchOS.

#### **Functions of Operating System**

Some typical operating system functions may include managing memory, files, processes, I/O system & devices, security, etc.

Below are the main functions of Operating System:

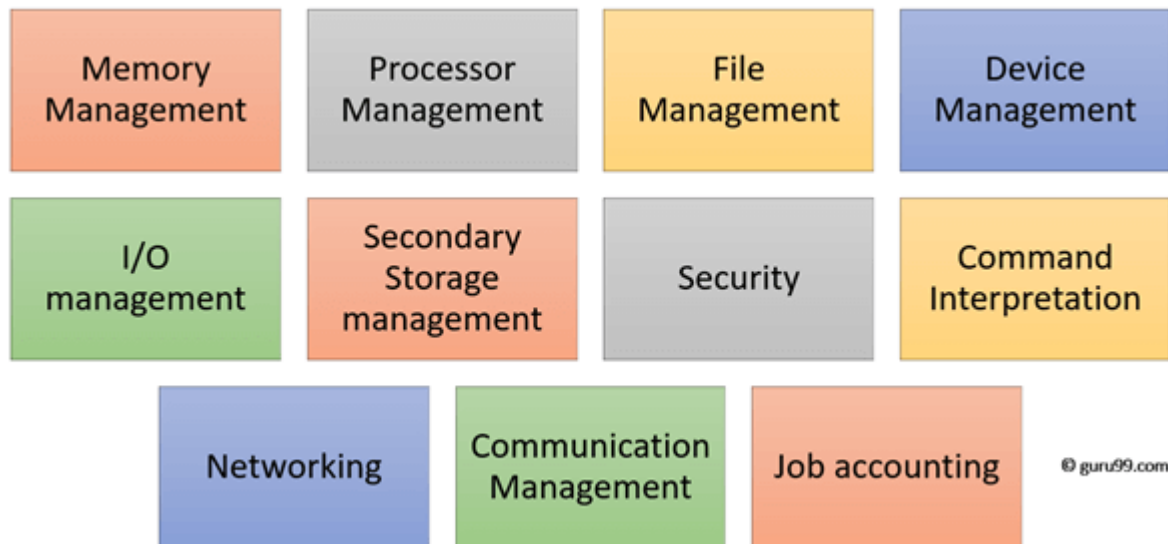

### Functions of Operating System

In an operating system software performs each of the function:

1. **Process management:** Process management helps OS to create and delete processes. It also provides mechanisms for synchronization and communication among processes.
2. **Memory management:** Memory management module performs the task of allocation and de-allocation of memory space to programs in need of this resources.
3. **File management:** It manages all the file-related activities such as organization storage, retrieval, naming, sharing, and protection of files.
4. **Device Management:** Device management keeps tracks of all devices. This module also responsible for this task is known as the I/O controller. It also performs the task of allocation and de-allocation of the devices.
5. **I/O System Management:** One of the main objects of any OS is to hide the peculiarities of hardware devices from the user.
6. **Secondary-Storage Management:** Systems have several levels of storage which includes primary storage, secondary storage, and cache storage. Instructions and data must be stored in primary storage or cache so that a running program can reference it.
7. **Security:** Security module protects the data and information of a computer system against malware threat and authorized access.
8. **Command interpretation:** This module is interpreting commands given by the acting system resources to process that commands.
9. **Networking:** A distributed system is a group of processors which do not share memory, hardware devices, or a clock. The processors communicate with one another through the network.
10. **Job accounting:** Keeping track of time & resource used by various job and users.
11. **Communication management:** Coordination and assignment of compilers, interpreters, and another software resource of the various users of the computer systems.

### Features of Operating System (OS)

Here is a list important features of OS:

- Protected and supervisor mode
- Allows disk access and file systems Device drivers Networking Security
- Program Execution
- Memory management Virtual Memory Multitasking
- Handling I/O operations
- Manipulation of the file system
- Error Detection and handling
- Resource allocation
- Information and Resource Protection

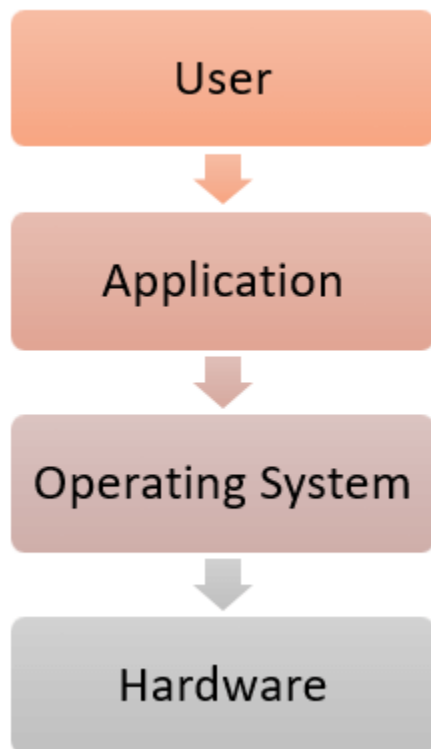

#### Advantages of Operating System

- Allows you to hide details of hardware by creating an abstraction
- Easy to use with a GUI
- Offers an environment in which a user may execute programs/applications
- The operating system must make sure that the computer system convenient to use
- Operating System acts as an intermediary among applications and the hardware components
- It provides the computer system resources with easy to use format
- Acts as an intermedior between all hardware's and software's of the system

#### Disadvantages of Operating System

- If any issue occurs in OS, you may lose all the contents which have been stored in your system
- Operating system's software is quite expensive for small size organization which adds burden on them.
- It is never entirely secure as a threat can occur at any time

#### Answer the questions.

1. What is an operating system?
2. Why does the user need the operating system?
3. How are operating systems classified?
4. What are the advantages and disadvantages of an operating system?

**Задание 2:** выполнение грамматических упражнений.

#### 1) Read some recommendations from an expert about care and handling of optical media. Translate them into Russian, paying attention to the highlighted grammar patterns.

1. **Keep** discs out of direct sunlight and with limited exposure to light in general.
2. **Avoid exposing** discs to large swings in temperature and humidity.
3. **Pick** discs straight up from a flat surface **rather than sliding** them.
4. **You must not flex** the discs when removing them from a recorder or disc drive or a storage case.
5. **I recommend holding** the discs on the outer edge or through the centre hole only to avoid



fingerprints on the bottom of the disc.

6. **Never touch** the underside of a disc and **never put** a disc down on any surface.

7. To label the disk, **you should** only **use** water-based or alcohol-based pens designed for optical discs.

8. **You had better not use** a ballpoint pen as it will damage the lacquer, mirror, and dye layers and create errors on the disc.

9. **It is a good idea to keep** the discs in protective cases when they are not being used.

**2) a) Write the recommendations of handling magnetic storage media and optical discs using the patterns in brackets. Add *not* where necessary.**

Magnetic storage:

- shake or hit the computer when it is operating (Avoid)
- format disks on which data is stored if you do not want to lose your data (Never)
- defragment your hard drive regularly (It is a good idea)
- leave hard drives near magnets (had better)
- store the tapes in consistently cool and dry environments (It is recommended)
- protect the tapes from external magnetic fields (must)

Optical storage:

- keep discs away from moisture and extreme temperatures (should)
- hold discs by the edges or by one edge and the centre hole (I recommend)
- clean the discs radially, that is, from the centre hole out to the edge, do not clean around the disc (rather than)

**b) Now rewrite the recommendations where informal patterns are used so that they sound more formal and can be used in technical documentation from the supplier.**

#### **5. Порядок выполнения работы**

1) изучение лексики, чтение текста, выполнение послетекстовых заданий;

2) повторение грамматического материала, выполнение упражнений

#### **6. Содержание отчета**

словарный диктант, контроль понимания прочитанного, продуктивная речь по теме с применением новых ЛЕ и грамматических конструкций “Warnings and recommendations”

## Практическое занятие 13. Сравнительная характеристика операционных систем

**1. Цель работы:** изучить новую лексику по теме, изучить грамматические конструкции “Sequencing of actions”

**2. Задачи работы:** научиться использовать новые лексические единицы в речи и понимать их в контексте, строить фразы с применением конструкций “Sequencing of actions”

**3. Подготовка к работе:** изучение новых ЛЕ и теоретического материала “Sequencing of actions”

**4. Задание 1:** прочитать текст и выполнить послетекстовые задания.

Linux vs. Windows vs. MacOS: Which Is the Operating System for You?

An operating system is simply defined as software that lets you manage a computer's hardware and resources while offering some common services that allow you to run different programs.

Computers have made enormous technological strides in the past couple of decades, evolving from bulky machines into sleek, performance-focused devices. And at the moment, there are three popular operating systems powering most computers:

- Windows
- macOS
- Linux

Microsoft Windows is the most popular desktop operating system in the world, with a market share of around 74 percent, according to **Statista**. Since its original release in 1985, the operating system has undergone a slew of changes, and despite its ups and downs (let's just forget Vista and Windows 8!), it's still the market leader by a long stretch.

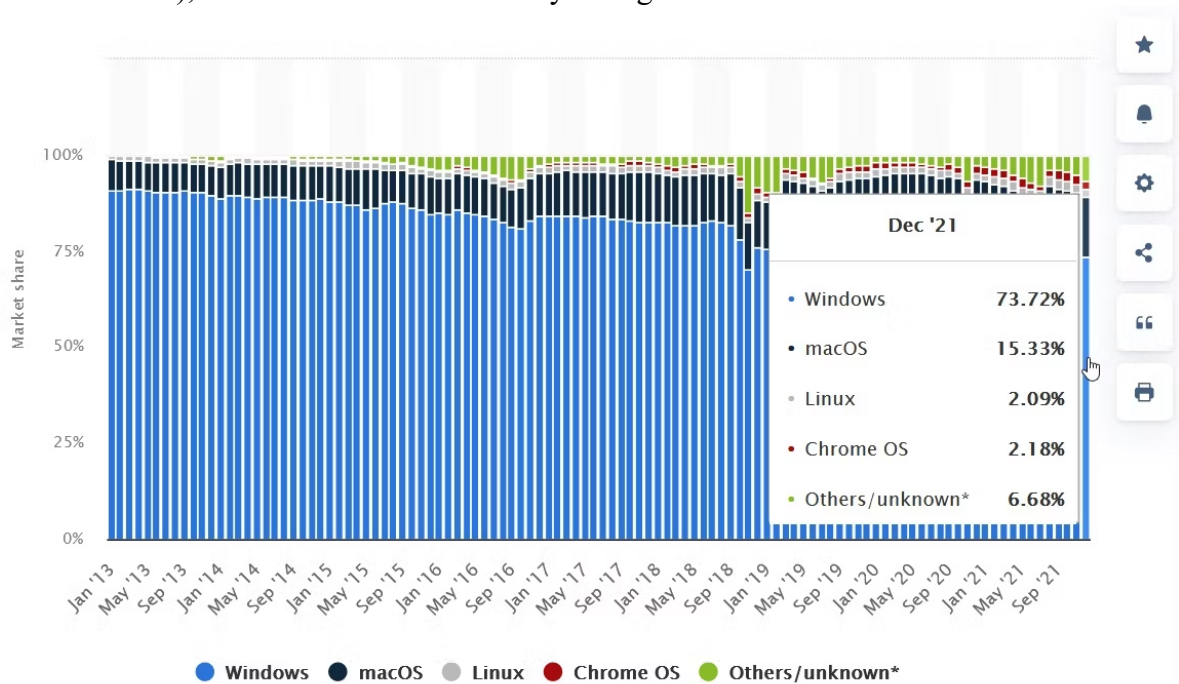

© Statista 2022

[Additional Information](#)

[Show source](#)

Microsoft Windows runs on computers around the globe. Its popularity has increased considerably, especially due to the popularity of Windows 10 and the free upgrade to Windows 11 that the company offers.

Microsoft Windows also ships on most laptops released today. Almost all major manufacturers pre-install Windows and add custom software before shipping them to consumers.

#### Ease of Installation

Windows is incredibly easy to install. It also works seamlessly with most hardware, which is one of the reasons why it's so popular. In addition, you can buy discs or purchase a digital copy, allowing you to create an image and install Windows on your computer.

#### Software Usability and Performance

This is where Microsoft Windows really shines. Almost every software runs seamlessly on Windows, primarily because of its install base. As a result, Windows is incredibly versatile, and most developers create apps or software that run natively on the platform.

Installation is incredibly easy and is carried out through an installation wizard. You don't need to be familiar with any command-line interface tool, even though one is available with Windows. If you're into gaming, Windows is the best choice. That's because the company has been focusing on improving gaming performance, and most developers and hardware manufacturers take advantage of options like DirectX 12, extracting the max performance out of a GPU and CPU.

#### MacOS

Apple's operating system has a relatively small install base compared to the might of Windows.

And yet, macOS continues to rise in popularity. Despite being Windows' biggest competitor, macOS takes a very different approach.

For starters, unlike Windows, you can't just buy a copy and install it on any computer. It also doesn't ship pre-installed with other computers; you can only get it with an iMac, MacBook, Mac mini, or other official Apple hardware.

### **Ease of Installation**

This one's incredibly easy. The operating system comes pre-installed with every MacBook and iMac the company sells, and you can run updates seamlessly. More importantly, updates are regular and relatively easy to install.

Updates are also much less frequent than Windows, so you don't have to worry about your Mac running updates at the most inconvenient times, something that's all too common with Windows. All iterations of macOS are also free.

While some may argue that there are disadvantages to buying a MacBook when compared with Windows, most others believe that despite the higher buy-in cost, the overall amount they spend across the cost of the system's lifetime is much less, since you don't have to worry about upgrades as much.

### **Software Usability and Performance**

Apple's operating system is incredibly popular because of its ease of use and its deep integrations with the Apple ecosystem. In addition, most people argue that installing and managing applications is just as easy, if not more, than Windows.

Although it's based on Linux, macOS lets you install software directly from the App Store. Or, most apps let you download a DMG file, which is a Disk Image file. Then, you just drag the icon into the Applications folder to install the app!

And, when you want to remove it, just delete it from the Applications folder. You don't have to worry about running any installation wizards. Developers and designers generally prefer macOS because of its support features for creative tools.

### **Linux**

Widely preferred by developers, Linux is an operating system known for its versatility. Unlike Windows and macOS, Linux is entirely open-source, so it can be modified and customized.

Since it's open-source, different variants, known as distributions, exist. There are even lightweight distributions that you can install on older PCs. In fact, Windows 11 shares quite a few similarities with Linux desktops!

These distributions range from software that offers core system functionality all the way to custom user interfaces designed for operating particular hardware. One of the most popular distributions is Ubuntu, widely used because of its flexibility.

### **Software Usability and Performance**

Compared to Windows or macOS, usability is limited. Running new software on Linux is not always easy, as not all programs offer native support (at least, most programs you'll find on Windows and macOS). This means you'll have to install a compatibility layer like Wine.

Previously, Linux GUIs paled in comparison with Windows or macOS, which offered better graphics and performance. However, that has changed now, with Ubuntu offering a stunning GUI that can easily compete with the likes of Finder and Windows Explorer.

Installing apps on Linux is a bit complicated. Ideally, you should know your way around a command-line interface tool since that's what you'll be using most of the time. Unfortunately, that's what limits Linux's adoption; people view it as too technical to be useful daily. Furthermore, most applications are free or open source substitutes for popular Windows or macOS apps, which may not be as good as their original, proprietary counterparts.

### **Which Operating System Is Right For You?**

So, as you can see, all three operating systems are great in their own right. But, it all depends on what you're familiar with and what you prefer to use. For example, if you like full control, Linux is probably the best choice. But if you want something easier to use, choosing between macOS and Windows is ideal.

- 1) What are the advantages and disadvantages of each operating system?
- 2) Which one will you prefer? Give reasons.

**Задание 2:** выполнить грамматические упражнения.

**Put the sentences describing the steps of obtaining a digital image in a digital camera in the correct order, adding the sequence words *first, then, next, after that, finally* to the sentences.**

- a) Light intensity and colour are analyzed by a semiconductor device, a CCD or CMOS.
- b) This electric charge is transferred and converted to an analogue voltage that is **amplified\*** and then sent to an analog to digital converter where it is digitized to be stored as a file.
- c) The CCD or CMOS chip generates an electric charge in proportion to the intensity of light that struck the sensors.
- d) Incident light is captured by the lens.
- e) The light focuses onto the silicon image sensor's photosites.

#### **5. Порядок выполнения работы**

- 1) изучение лексики, чтение текста, выполнение послетекстовых заданий;
- 2) повторение грамматического материала, выполнение упражнений

#### **6. Содержание отчета**

словарный диктант, контроль понимания прочитанного, продуктивная речь по теме с применением новых ЛЕ, использование sequencing words в речи

## Практическое занятие 14. Обобщение лексического и грамматического материала

**1. Цель работы:** обобщить знание изученных ЛЕ, повторить изученные грамматические конструкции

**2. Задачи работы:** обобщение лексико-грамматических навыков

**3. Подготовка к работе:** повторение теоретического материала, повторение изученных ЛЕ общей лексики и терминов профессиональной лексики

**4. Задание:** тест

1. Найдите два правильных варианта перевода:  
удаленная работа

- a) **remote work**
- b) home work
- c) **teleworking**
- d) work from house

2. Найдите верный термин к данному определению:

The ability to deal with people in physical reality and solve communication problems.

- a) community skills
- b) **soft skills**
- c) hard skills
- d) real skills

3. Закончите предложение (возможны два правильных варианта ответа):

People post updates about recent events in their lives and publish their opinions on hot issues on \_\_\_\_\_.

- a) **social networks**
- b) social groups
- c) **social media**
- d) social space

4. Какое слово не является синонимом слова *conventional*?

- a) traditional

- b) normal
- c) regular
- d) basic**

5. Выберите верную форму глагола (возможны два правильных варианта ответа):

To enter your profile, you \_\_\_\_\_ to type in your log-in name and password.

- a) needs
- b) are needing
- c) need**
- d) will need**

6. Выберите два верных утверждения:

**a) Video conferencing through computers can connect people in various locations, allowing companies and employees to save time and cut travelling costs.**

b) The use of the computer in banking increases the infrastructure cost of banks.

c) General-purpose computers perform a wide range of computationally intensive tasks in various fields, including quantum mechanics, weather forecasting, oil and gas exploration, airplane and spacecraft aerodynamics, etc.

**d) Expert systems help doctors to diagnose the diseases of patients faster thanks to various medical software applications which can analyze blood and urine tests, X-ray and MRT images, etc.**

7. Что из перечисленного не является устройством ввода?

- a) speakers**
- b) keyboard
- c) mouse
- d) barcode reader

8. Что из перечисленного не является подключаемым устройством?

- a) expansion card
- b) image scanner
- c) digital camera
- d) main memory**

9. Выберите правильную расшифровку аббревиатуры:

CPU

- a) centre processing unit
- b) central processing unit**
- c) central processor unit
- d) central process unit

10. Выберите верный вариант заполнения пропусков:

\_\_\_\_\_ program is not working because \_\_\_\_\_ strings in it contain \_\_\_\_\_ errors.

- a) the, -, the
- b) a, some, -
- c) a, -, some
- d) the, some, -**

11. Закончите предложение:

A computer processor has the form of a silicon microprocessor chip which represents an \_\_\_\_\_.

- a) integrated circuit**
- b) input device
- c) internal circuit
- d) integrated circle

12. Выберите правильную расшифровку аббревиатуры:

USB

- a) universal series bus
- b) universal serial bus**
- c) uniform serial bus

d) universe series bus

13. Выберите верное определение к термину:

volatile (memory)

a) maintaining the stored data when the power is interrupted

b) retaining its contents when not powered

**c) requiring power to retain stored information**

d) capable of storing its contents without power supply

14. Выберите верное определение к термину:

RAM

**a) a type of volatile memory used to hold instructions and data of currently running programs**

b) a type of volatile memory used to store data permanently

c) a type of non-volatile memory that can be read and changed in any order

d) a type of non-volatile memory keeping the OS, application programs and data in current use

15. Выберите верную форму глагола:

All types of computer can \_\_\_\_\_ as machines that can be programmed to manipulate data.

a) define

b) are defined

c) defined

**d) be defined**

16. Выберите верный вариант объяснения слова:

simultaneous

a) operating in a similar way

b) occurring at the same place

**c) taking place at the same time**

d) happening rapidly

17. Вставьте пропущенное слово:

A \_\_\_\_\_ can be defined as a relatively small lightweight computer incorporating a display and keyboard.

a) mainframe

b) desktop PC

c) wearable

**d) laptop**

18. Вставьте пропущенные слова:

\_\_\_\_\_ lets the user create, edit, save and store documents on the computer and print them out.

a) memory capacity

**b) desktop publishing**

c) word processing

d) hands-free operation

19. Выберите верный вариант перевода слова:

versatile

a) практичный

**b) универсальный**

c) эффективный

d) возможный

20. Подберите верные синонимы к слову (возможны два правильных варианта ответа):

temporary

**a) short-term**

b) permanent

c) long-lasting

**d) non-permanent**

21. Закончите предложение:

A CPU having four cores is called a/an \_\_\_\_\_ -core processor.

- a) dual
- b) octa
- c) quad**
- d) single

22. Закончите предложение:

The central processor is made up of three main parts:

- a) the control unit, the arithmetic/logic unit, and memory unit.**
- b) the control unit, the arithmetic/logic unit and registers.
- c) the control unit, memory unit and registers.
- d) the arithmetic/logic unit, memory unit and registers.

23. Закончите предложение:

The \_\_\_\_\_ is a device within the CPU that sends out a steady high-frequency signal to all other computer components to measure and synchronize the flow of data.

- a) clock rate
- b) clock cycle
- c) system clock**
- d) system cycle

24. Что из перечисленного является устройством основной (первичной памяти)?

- a) solid-state drive
- b) ROM**
- c) hard disk drive
- d) memory stick

25. Выберите правильный предлог:

Virtual memory moves the data that has not been used recently \_\_\_\_\_ a storage device.

- a) to
- b) in
- c) onto**
- d) across

26. Выберите правильный термин к определению:

\_\_\_\_\_ is the technique used to reduce the average time to access data from the main memory.

- a) Cache memory**
- b) virtual memory
- c) external memory
- d) read-only memory

27. Закончите предложение:

Magnetic and optical storage devices are referred to as \_\_\_\_\_ memory, because they read stored data in a sequence, in contrast to \_\_\_\_\_ memory where data can be accessed in any order.

- a) internal, external
- b) sequential access, random-access**
- c) virtual, read-only
- d) cache, secondary

28. Выберите правильный перевод слова:

front-side bus

- a) передняя шина
- b) фронтальная шина
- c) системная шина**
- d) шина расширения

29. Выберите три компонента современной материнской платы:

- a) CPU chip**
- b) northbridge/southbridge**

c) floppy-disk controller

**d) CMOS battery**

30. Закончите предложение:

\_\_\_\_\_ keys appear at the top of the keyboard and can be programmed to do special tasks like “display help screen” or “print screen”.

a) Dedicated

b) Numeric

**c) Function**

d) Directional

31. Выберите правильную форму слова:

The keyboard is an input device used to enter data into a computer through \_\_\_\_\_ it in.

a) typed

**b) typing**

c) type

d) types

32. Выберите правильную форму глаголов (возможны два правильных варианта ответа):

If you \_\_\_\_\_ the Enter key, the cursor \_\_\_\_\_ to the beginning of a new line.

**a) press, moves**

b) will press, will move

**c) press, will move**

d) presses, moves

33. Выберите верный союз:

The CPU accesses the main memory \_\_\_\_\_ it finds the required entry in the cache. a) if

**b) unless**

c) when

d) in case

34. Выберите правильный ответ к утверждению:

Most of the fundamental elements of modern personal computing: windows, hypertext, graphics, efficient navigation and command input, video conferencing, word processing and some other were developed in the \_\_\_\_\_.

a) 1950s

**b) 1960s**

c) 1970s

d) 1980s

35. Выберите три универсальных компонента компьютерной мыши:

**a) wheel**

**b) buttons**

c) cable

**d) circuit board**

36. Назовите три функции мыши, которые описаны в задании:

You can move a file across the desktop and insert it in a folder. If you place the mouse over an object, some additional information about the object can be seen on the screen, on condition that it is attached to the object. Also, you can change the shape of a graphic object, e.g. convert a square into a rectangle.

a) drag, highlight, click

b) insert, double-click, drop

**c) drag-and-drop, hover, stretch**

d) scroll, grab, select

37. Выберите правильное определение к термину:

ASCII

a) It is the most common encoding format for multimedia data used in computers and telecommunication equipment.



- b) It is an encoding format used on the World Wide Web.
- c) It is an encoding format that enables to represent text and images in computers and telecommunication equipment.
- d) It is the most common character encoding format for text data in computers and on the internet.**

38. Выберите два определения слова:

pixel

- a) an element of a light-sensitive image sensor**
- b) an element of a vector image
- c) the basic element of a printed bitmapped image
- d) the basic element of a digital bitmapped image**

39. Закончите предложение:

The camera's ability to present a detailed image based on the total amount of pixels captured is called \_\_\_\_\_.

- a) clarity
- b) acutance
- c) sharpness

**d) resolution**

40. Закончите предложение:

The three primary colours an image is made up of are \_\_\_\_\_.

- a) green, red and blue**
- b) green, red and yellow
- c) red, green and black
- d) blue, green and white

41. Закончите предложение:

Civil engineering a discipline that deals with the construction and maintenance of \_\_\_\_\_.

- a) residential areas
- b) military objects
- c) infrastructure objects**
- d) civil buildings

42. Выберите тип сканера, соответствующий утверждению:

This type of scanner can only work as long as the base containing the image is transparent.

- a) flatbed
- b) slide**
- c) hand-held
- d) 3D

43. Выберите правильную расшифровку аббревиатуры:

QR code

- a) quick reply code
- b) quite response code
- c) quick respond code

**d) quick response code**

44. Закончите предложение:

\_\_\_\_\_ is a physical electronic authorization device used to control access to a resource.

- a) magnetic card
- b) identity card
- c) smart card**
- d) credit card

45. Выберите верный перевод термина:

оптическое распознавание символов

- a) optical character recognition**
- b) optic character recognition

c) optical character recognizing

d) optical characters recognition

46. Выберите правильные формы глаголов:

– I've got a problem! Microsoft Word \_\_\_\_\_! It \_\_\_\_\_ perfectly an hour ago!

– \_\_\_\_\_ you \_\_\_\_\_ to restart the computer?

– Not yet.

a) doesn't work, worked, did ...try

b) isn't working, has worked, have ...tried

c) doesn't work, is working, did ...try

**d) isn't working, worked, have ... tried**

47. Подберите синоним к слову:

implement

a) put

**b) apply**

c) show

d) start

48. Закончите предложение:

Today, most LCD displays use \_\_\_\_\_ technology.

a) passive matrix

**b) active matrix**

c) cathode ray tube

d) active colour

49. Выберите правильные формы прилагательных:

Organic light-emitting diode (OLED) monitors are thin-film LED displays that do not require a backlight to function; therefore they are \_\_\_\_\_ and \_\_\_\_\_. They offer \_\_\_\_\_ contrast and \_\_\_\_\_ colour reproduction. They are far \_\_\_\_\_ than LCD monitors and are \_\_\_\_\_ type of monitor.

**a) thinner, more efficient, higher, better, less common, the most expensive**

b) thinner, more efficient, highest, better, more common, the most expensive

c) more thin, more efficient, higher, best, less common, expensiver

d) thinner, more efficient, highest, better, less common, more expensive

50. Подберите верный термин к определению:

The correlation between the width and height of a monitor.

a) screen size

b) dot pitch

**c) aspect ratio**

d) viewing angle

51. Найдите предложения в страдательном залоге, соответствующие предложениям в действительном залоге:

Yesterday the company moved the head office to a new location. The vendors have already supplied the latest accounting software. Now the employees can maintain book-keeping more efficiently.

a) Yesterday the head office of the company was moved to a new location. The latest accounting software has been already supplied. Now book-keeping can maintained more efficiently.

**b) Yesterday the head office of the company was moved to a new location. The latest accounting software has been already supplied. Now book-keeping can be maintained more efficiently.**

c) Yesterday the head office of the company did moved to a new location. The latest accounting software has been already supplied. Now book-keeping can be maintained more efficiently.

d) Yesterday the head office of the company was moved to a new location. The latest accounting software has been already supplied. Now book-keeping can be maintain more efficiently.

52. Выберите два верных утверждения:

**a) Unlike bitmapped images, vector images can be scaled up to any resolution without**

**losing quality.**

b) Plotters are machines used to produce raster images.

**c) Additive manufacturing is the process of creating an object by putting the material in layers, one layer at a time, until the object is built.**

d) Thermal transfer printers can print on plastic, paper, fabric, and metal material. They cannot produce medium-resolution graphics.

53. Подберите верное определение к термину:

subtractive manufacturing

a) An industrial production technique where material is deposited in layers to create a 3D object.

**b) A process of creating an object by removing material from a solid block until the final product is complete.**

c) A production method in which an object is manufactured by sintering small particles of polymer powder into a solid structure.

d) A method of creating objects where the shape and colour of the object is mathematically defined.

54. Выберите правильные формы глаголов:

I only \_\_\_\_\_ that I \_\_\_\_\_ the bill when my Internet connection \_\_\_\_\_ working.

a) remembered, didn't pay, had stopped

b) had remembered, hadn't paid, stopped

**c) remembered, hadn't paid, stopped**

d) remembered, hadn't paid, had stopped

55. Выберите предложение, соответствующее по смыслу предложению в задании:

A hard-disk drive is assigned to the C: drive.

**a) An HDD is labelled with the C: drive letter.**

b) An HDD is mounted on the C: drive.

c) An HDD is located on the C: drive.

d) An HDD is connected to the C: drive letter.

56. Подберите верный термин к определению:

The creation of one or more regions on HDD, so that each region can be managed separately.

a) formatting

**b) partitioning**

c) fragmentation

d) division

57. Выберите два предложения, соответствующие ситуации:

The internet connection is unstable, so the videoconference is impossible now.

**a) If the internet connection was stable, we could have a videoconference now.**

**b) If we had a stable internet connection, the videoconference would be possible.**

c) We could have a conference now in case the internet connection gets unstable.

d) The videoconference wouldn't be possible unless we had a stable internet connection.

58. Выберите верный ряд определений:

CD data is represented as tiny indentations known as \_\_\_\_\_, etched by the laser in a spiral track on the polycarbonate layer. The flat areas between them are known as \_\_\_\_\_. The distance between the tracks is called the \_\_\_\_\_.

a) hollows, lands, pitch

b) bumps, pits, land

**c) pits, lands, pitch**

d) pits, bumps, spacing

59. Выберите верное слово-связку (возможны два правильных варианта ответа):

The DVD laser spot size is smaller than that of a CD, so the laser can be focused to a smaller area on a disc. \_\_\_\_\_, the pits on a DVD can be made smaller, too.

**a) therefore**

b) however

**c) consequently**

d) although

60. Подберите верный перевод термина:

floating-gate transistor

a) транзистор с плавающим выходом

b) транзистор с переменным затвором

c) транзистор с перемещающимся затвором

**d) транзистор с плавающим затвором**

61. Какое из перечисленных устройств хранения не относится к устройствам с флеш-памятью?

a) SSD

**b) SIM card**

c) MicroSD card

d) memory stick

62. Выберите грамматически верное предложение:

a) I recommend to hold the discs on the outer edge or through the centre.

b) Never don't touch the underside of a disc or put a disc down on any surface.

c) You had better not to use a ballpoint pen to label a disc.

**d) Avoid exposing discs to large swings in temperature and humidity.**

**5. Порядок выполнения работы**

повторение грамматического и лексического материала, выполнение теста

**6. Содержание отчета**

итоговое тестирование

## Практическое занятие №1. Типы интерфейсов

- 1. Цель работы:** Развитие монологической речи, умение подготовить высказывание по теме “предпосылки для успешной карьеры в сфере информационной безопасности”
- 2. Задачи работы:**
  - ввести лексические единицы по теме “ Типы интерфейсов”
  - освоить составление монологического высказывания по теме “ Типы интерфейсов”, используя необходимые лексические единицы
  - освоить навыки составления презентаций
- 3. Подготовка к работе**  
Повторение слов по теме “ Типы интерфейсов”
- 4. Задание**

Input devices are the pieces of hardware which allow us to enter information into the computer. The most common are the keyboard and the mouse. Examples of input devices include:

- **Keyboards:** Allow users to input alphanumeric data and commands.
- **Pointing devices and game controllers:** Allow users to direct application software and interact with graphical user interfaces.
- **Audio and video devices:** Allow users to capture sound and images.

We can also interact with a computer by using one of these: a light pen, a scanner, a trackball, a graphics tablet a game controller or a microphone.

Input also may come from other computers via input/output (I/O) devices, like network adapters and Bluetooth devices.

### The Keyboard

A standard PC keyboard has various groups of keys:

**Cursor control keys** include arrow keys that move the insertion point up, down, right and left, and keys such as End, Home, Page Up and Page Down, which are used in word processing to move around a long document.

**Alphanumeric keys** represent letters and numbers, as arranged on a typewriter.

**Function keys** appear at the top of the keyboard and can be programmed to do special task

**Dedicated keys** are used to issue commands or produce alternative characters. For example: **Ctrl** changes the functions of other keys [e.g. Ctrl + X cuts the selected text). **Caps Lock** sets the keyboard in “CAPITALS” mode; it only affects letters. **Enter** (or Return) is pressed to select options from a menu or to start a new paragraph.

**Backspace** deletes the character to the left of your current position.

A **numeric keypad** appears to the right of the main keyboard. The Num Lock key is used to switch from numbers to editing keys.

### The Mouse

A mouse is a hand-held device that lets you move a pointer or a cursor and select items on the screen. It has one or more buttons to communicate with the PC. A scroll wheel lets you move through your documents or web pages. The pointer looks like an I-bar, an arrow or a pointing hand.

An optical mouse has an optical sensor instead of a ball underneath. A cordless (wireless) mouse has no cable: it sends data via infrared signals or radio waves. Mouse actions:

- **to click**, press and release the left button;
- **to double-click**, press and release the left button twice;
- **to drag**, hold down the button, move the pointer to a new place and then release the button;
- **to right-click**, press and release the right button; this action displays a list of commands.

**6. Which input device (keyboard, mouse, light pen, scanner, trackball, joystick, graphics tablet, touch screen, barcode reader, touchpad, game controller, microphone, digital camera, webcam) would you use for these tasks?**

- 1) to play computer games;
- 2) to copy images from paper into computer;
- 3) to read price labels in a shop;
- 4) to select text and click on links on web pages;
- 5) to enter drawings and sketches into a computer;
- 6) to input voice commands and dictate text;
- 7) to draw pictures or select menu options directly on the screen;
- 8) to take and store pictures and then download them to a computer.

7. Match the descriptions (1–8) with the names of the keys (a–h):

1. A long key at the bottom of the keyboard. Each time it is pressed, it produces a blank space.	a) arrow keys
2. It moves the cursor to the beginning of a new line. It is also used to confirm commands.	b) return/enter
3. It works in combination with other keys. For example, you press this key and C to copy the selected text.	c) Caps Lock
4. It removes the character to the left of the cursor or any selected text.	d) shift
5. It produces UPPER CASE characters.	e) tab
6. It produces UPPER CASE letters, but it does not affect numbers and symbols.	f) space bar
7. It moves the cursor horizontally to the right for a fixed number of spaces (in tabulations and data fields).	g) backspace
8. They are used to move the cursor, as an alternative to the mouse.	h) Ctrl

**8. Answer the questions:**

1. What is an input device? What input devices do you know?
2. What are the functions of dedicated keys?
3. What is a mouse?
4. What are mouse actions?

**10.** Find the words and word combinations (1–15) in the text above. Can you guess the meaning from context? Give Russian equivalents.

1. Input devices	9. Alphanumeric keys
2. Pointing devices	10. Function keys
3. Game controllers	11. Dedicated keys
4. Light pen	12. Numeric keypad
5. Trackball	13. To click, to double-click, to right-click
6. Graphics tablet	14. To drag
7. Cursor control keys	15. Barcode reader
8. To interact with graphical user interfaces	

#### 4. Порядок выполнения работы

Выполнить задания , изучить материал

#### 5. Содержание отчета

конспект

## Практическое занятие 2. GUI

**1. Цель работы:** Развитие монологической речи, умение подготовить высказывание по теме “предпосылки для успешной карьеры в сфере информационной безопасности”

#### 2. Задачи работы:

- ввести лексические единицы по теме “карьера”
- освоить составление монологического высказывания по теме “ GUI ”, используя необходимые лексические единицы
- освоить навыки составления презентаций

#### 3. Подготовка к работе

Повторение слов по теме “GUI ”

#### 4. Задание

## APPLICATION PROGRAMS

An Application Program is a software program that performs a specific function, such as accounting, word processing or drafting. There are some categories of application program to choose from spreadsheet, Database Management, Computer Aided Design (CAD), Communications, Graphic presentations, desktop Publishing, Integrated Programs, Window and Windows – based Programs. Within each category, there are several software programs which have gained industry-wide acceptance.

Word processing: is the most common application for a personal computer. Most word processing software programs allow us to create, edit, and save documents, along with changing the position of the text in a document, inserting new information in the middle of the text, or removing words and sections no longer needed. With a typewriter, you would have to re-type the entire document after a few major changes. Given a computer, a document can be stored electronically and retrieved at any time for modification.

Examples of word processing programs include: Word Perfect; MS-Word; Multimate; Wordstar; Displaywrite; Word for Windows; Word Perfect for Windows.

Accounting and spreadsheets: One of the primary functions of the first mainframe computers was to store and calculate volumes of financial data for banks and large businesses. Nowadays, a personal computer is capable of handling the accounting and finances of almost any small to medium-sized business. Many different programs are available for plotting financial trends and performing everyday bookkeeping functions. One of the most popular financial tools is called a spreadsheet. An electronic spreadsheet is a software program, which performs mathematical calculations and ‘what – if’ analysis. Besides replacing your pencil and calculator for solving financial and statistical problems, spreadsheets can display line graphics, bar charts, and scatter plot diagrams. Often accounting and spreadsheet programs are designed to work together, in efforts to provide the financial solution.

Examples of accounting programs include: ACCPAC Simply Accounting, ACCPAC plus, Business Vision Turbo, New Views Accounting, Great Plains, Dac Easy, Peach Tree, Abacus II.

Examples of spreadsheet programs include: Lotus 1-2-3, MS-Exel, Quatro Pro, Supercalc.

Database Management. A database is a simply collection of related information. Some common examples are a phone book, an inventory list, a personal file. A Database Management Software program assists in manipulating and organizing the information in a database. A database application is any task ordinarily handled by a filing cabinet, multiply file folders, or some other information storage system. In a manual system, for example, each drawer in filing cabinet is reserved for a specific purpose, such as maintaining profile sheets on customers. Each profile is written on a standard form and a clerk places the file folder in the drawer. This manual process is identical to a computerized database, where the database software performs the function of the filing clerk. Rather than placing the customer profiles in the filing cabinet drawer, a computerized database stores each profile electronically on a disk.

Some examples of a database management programs: Dbase, R:BASE, Paradox, FoxPro, Q&A, Oracle.

Computer Aided Design. Computers are the perfect tools for creating drawing or architectural plans. Because the drawings can be saved, it is easy to incorporate modifications, design improvements and corrections. Computers are often used on the final process of converting a computer drawing into a physical product. One such example is the manufacturing of electronic circuit boards. First, the electronic circuit drafting program produces the schematic design, then a second program tests the design by simulating the circuit’s operation, and finally a third program constructs the circuit board from the design layout.

Computer Aided Design programs are: AutoCAD, TANGO, PCAD, Generic CAD.

Communications: Computers can communicate with each other via regular telephone lines and modems.

Communication software programs enable different types of computers to exchange data using a common language. The IBM PC can actually emulate various types of equipment, around the world, with the help of software. Communication programs are: Smartcom, Kermit, Crosstalk, PC Talk, Pro Comm, PC Anywhere, CloseUp.

Graphic Presentations: There are actually some people, who prefer to look at 14 columns of numbers across several pages for analyzing a business’ performance. These people are called accountants. However, most people are visual learners of diagrams, graphs and charts for representing numerical trends. There are a variety of programs for displaying information graphically: –Lotus 1-2-3, Exel, Quatro Pro, Chartmaster, Chart, Harvard Graphics, Micrografix Powerpoint, DrawPerfect.



Desktop Publishing is the process of taking a document and inserting graphics and applying enhanced formatting options. These programs take text from the more common word processor and produce print-shop quality output. Desktop publishing programs are used to create newsletters, brochures, reports, book and other publications. Desktop publishing programs include: Aldus PageMaker, Ventura Publisher, AMI Professional. Integrated Programs: they unite one or more of the primary computer applications, whether word processing, spreadsheet or database into a single package. These programs allow people to experiment with the major computer applications, while only investing in a single product. The most popular integrated programs are: –MS-Works, Q&A, Eight in one, Symphony, Framework.

Microsoft Windows. Windows is a program, which enhances many aspects of using a microcomputer. It provides a graphical user interface (GUI and pronounced «Gooney») for programs running under the Windows environment. In other words, Windows allows a person to use a mouse and choose special symbols to point at and select desired functions, rather than having to remember commands. As well Windows' products allow a WYSIWYG ('what you see is, what you get') screen display, especially important for word processing and desktop publishing programs.

### **1. Translate these into your own language:**

software program  
application program  
industry-wide acceptance  
along with changing the position  
no longer needed  
to re-type the entire document  
calculate volumes of financial data  
bookkeeping functions  
to assist in manipulating and organizing the information  
perfect tools  
program tests the design  
emulate various types  
select desired functions

### **2. Find English equivalents to the following words and expressions in the text:**

выполнять специфическую функцию  
самая распространенная прикладная программа  
создавать, редактировать, сохранять документы  
вставлять новую информацию  
удалять слова, которые больше не нужны  
получить в любое время  
быть способным, быть в состоянии что-либо выполнять  
ручной процесс  
пласт  
используется, чтобы создать  
позволяет людям экспериментировать  
выбрать

### **3. Finish the sentences according to the text:**

An application program is a software .....  
Word processing software programs allow us .....  
An electronic spreadsheet is a .....  
A data base application is any task .....  
Computers are perfect tools for .....  
Communication programs enable different types of computers .....  
There are people who prefer to look at 14 columns of numbers across several pages for .....

These programs take text from the more common word processor and ..... .

Windows allows a person ..... .

**4. What kind of programs do you choose to perform the following tasks:**

to create, edit and save documents;

to make a phone book, inventory list, a personal file;

to store and calculate volumes of financial data for banks;

to use a mouse and choose special symbols to point at and select desired functions;

to create drawings or architectural plans;

to communicate with other persons via regular telephone to exchange data using a common language;

to unite one or more of the primary computer applications.

**5. Give appropriate definitions and examples of the following application programs:**

word-processing

accounting and spreadsheets

database management

computer aided design

communications

graphic presentations

desktop publishing

Microsoft Windows

**6. Answer the questions:**

What is an application program?

What does word processing software program allow to do?

What was one of the primary functions of the first mainframe computers?

What is a personal computer capable doing now?

What is spreadsheet?

What is database?

What are the perfect tools for creating drawings?

What are desktop publishing programs used to?

What is windows?

**4. Порядок выполнения работы**

Выполнить задания , изучить материал

**5. Содержание отчета**

конспект

### Практическое занятие 3. Введение в программирование

**1. Цель работы:** Развитие монологической речи, умение подготовить высказывание по теме «Языки программирования»

**2. Задачи работы:**

- ввести лексические единицы по теме “ введение в программирование “, используя необходимые лексические единицы
- освоить навыки составления презентаций

**3. Подготовка к работе**

Повторение слов по теме « введение в программирование»

## COMPUTER PROGRAMMING

Programming is the process of preparing a set of coded instructions which enables the computer to solve specific problems or to perform specific functions. The essence of computer programming is the encoding of the program for the computer by means of algorithms. The thing is that any problem is expressed in mathematical terms, it contains formulae, equations and calculations. But the computer cannot manipulate formulae, equations and calculations. Any problem must be specially processed for the computer to understand it, that is – coded or programmed.

The phase in which the system's computer programs are written is called the development phase. The programs are lists of instructions that will be followed by the control unit of the central processing unit (CPU). The instructions of the program must be complete and in the appropriate sequence, or else the wrong answers will result. To guard against these errors in logic and to document the program's logical approach, logic plans should be developed.

There are two common techniques for planning the logic of a program. The first technique is flowcharting. A flowchart is a plan in the form of a graphic or pictorial representation that uses predefined symbols to illustrate the program logic. It is, therefore, a "picture" of the logical steps to be performed by the computer. Each of the predefined symbol shapes stands for a general operation. The symbol shape communicates the nature of the general operation, and the specifics are written within the symbol. A plastic or metal guide called a template is used to make drawing the symbols easier.

The second technique for planning program logic is called pseudocode. Pseudocode is an imitation of actual program instructions. It allows a program-like structure without the burden of programming rules to follow. Pseudocode is less time-consuming for the professional programmer than is flowcharting. It also emphasizes a top-down approach to program structure. Pseudocode has three basic structures: sequence, decision, and looping logic. With these three structures, any required logic can be expressed.

### 1. Copy the following words and word combinations into your notebooks:

equation – уравнение/приравнивание;

list of instructions – перечень команд;

guard – защищать/охранять;

appropriate sequence – необходимая последовательность;

program logic – логическая последовательность выполнения программы;

flowchart – блок-схема;

flowcharting – построение блок-схемы;

pictorial representation – наглядное представление;

predefined symbols – заранее заданные символы;

emplate – шаблон/образец;

pseudocode – псевдокод/псевдопрограмма;

burden – издержки/затраты;

consume – потреблять/расходовать;

emphasize – выделять/подчеркивать;

top-down approach – принцип нисходящей разработки;

looping logic – логическая схема выполнения (операций) в цикле.

## **2. Answer the following questions:**

What is programming?

What is the essence of programming?

What should be done with the problem before processing by the computer?

What is a program?

What are instructions?

What are the main techniques for planning the program logic?

What is a flowchart?

What is a template and what is it used for?

What do you understand by "pseudocode"?

What are the basic structures of pseudocode?

## **3. Find English equivalents for the following words in the text:**

совокупность закодированных команд;

суть компьютерного программирования;

кодирование посредством алгоритма;

необходимая последовательность;

составлять план логической последовательности;

логическая последовательность выполнения программы;

построение блок-схемы;

псевдопрограмма.

#### 4. Match the phrases from the first column to the words from the second one:

application program;	выполняемая программа;
binary program;	сторожевая программа;
archived program;	вспомогательная программа;
operating (system) program;	программа в двоичном коде;
running program;	программа моделирования;
watch-dog program;	дистанционная программа;
simulation program;	прикладная программа;
remote program;	сервисная программа;
support program;	программа операционной системы;
utility program.	заархивированная программа.

#### 4. Порядок выполнения работы

Выполнить задания , изучить материал

#### 5. Содержание отчета

конспект

## Практическое занятие 4. Языки программирования

**3. Цель работы:** Развитие монологической речи, умение подготовить высказывание по теме «Языки программирования»

**4. Задачи работы:**

- ввести лексические единицы по теме “ Языки программирования “, используя необходимые лексические единицы
- освоить навыки составления презентаций

**3. Подготовка к работе**

Повторение слов по теме « Языки программирования»

### PROGRAMMING LANGUAGES

Programming has been with us for over 40 years but it wasn't born at the time as the first computers. When the first early computers were built, there were no programming languages. First machines were initially programmed by flipping toggle switches and changing cables. Needless to say, this was a slow, awkward process. People began quickly searching for a better, faster way to issue instructions to the computer. The result was what we call Programming Languages. The programming languages fall into three general categories. They are comprised of ones and zeros, and are directly understood or executed by hardware. Electronic circuitry turns these 0s and 1s into the operations the computer performs.

Assembly Languages are powerful programming tools because they allow programmers a large amount of direct control over the hardware. They offer programmers greater ease in writing instructions but preserve the programmer's ability to declare exactly what operations the hardware performs. Assembly languages are machine-specific, or machine-dependent. Machine-dependent means the instructions are specific to one type of computer hardware. Assembly languages are still provided by most computer manufacturers – they can't be translated and used on another computer.

Assembly code for a Prime mini won't work on a Digital mini. Assembly code can't even be transferred between some machines built by the same manufacturer. For the most part, assembly languages are used by systems programmers to develop operating systems and their components.

So Assembly languages were the first bridge between the English Language and the computer's binary language. The creation of high-level programming languages followed. A high-level language is a language in which each instruction or statement correspond to several machine code instructions.

As high-level languages are a method of writing programs using Englishlike words as instructions, they allow users to write in a notation with which they are familiar, e.g., Fortran in mathematical notation.

High-level programming languages combine several machine language instructions into one high-level instruction. Low-level languages required only a single letter or a short mnemonic a term, or a word that is easy to identify, such as ADD for addition. High-level language requires just a single statement.

A Statement is an expression of instruction in a programming language. For example, PRINT FILE, TXT is a statement. A statement translates into one or more instructions at the machine language level. Each programming language includes a set of statement and a syntax. Syntax is the set of rules governing the language's structure and statements. The syntax rules may include how statements are written, the order in which statements occur, and how sections of programs are organized.

FORTRAN was created in 1954 by John Backus. And it was one of the first high-level languages for FORMular TRANslator. Fortran allows programmers to calculate complex formulas with a few source code instructions. It is used for scientific and mathematical problems. The source program is written using combination of algebraic formulas and English statements of a standard but readable form.

Another high-level machine language is Cobol. Cobol was developed by the Conference on Data Systems Languages. Cobol was issued by the US Government Printing Office in 1960. Cobol stands for Common Business-Oriented Language. The source program is written using statements in English. It was made for business industry, government and education applications. This means that Cobol «has a place for everything» and requires programmers to «put everything in its place». Cobol programs are separated into four divisions:

1. The Identification Division (раздел идентификации) documents the program name, the programmer's name (s), dates and any other important identification information.
2. The Environment Division names the computer hardware, including the CPU and I/O devices.
3. Data Division identifies all associated files and working storage sections of the program.
4. The Procedure Division contains all the instructions in the Cobol program.

Cobol divisions are further divided into paragraphs and sections. This structure helps programmers write code efficiently and with a minimum of repetition and confusion.

Algol was developed as an international language for the expression of the algorithms between individuals, as well as programming language. It was introduced in the early 1960s. Algol stands for ALGOritmic Language. This language is used for mathematical and scientific use. An Algol program consists of data items, statements and declarations, organized into a program structure BASIC or the Beginners AU-purpose Symbolic Instruction Code, was developed over a period of years by professors John Kemeny and Thomas Kurtz and students in the computer science program at Dartmouth College. It was released in 1965. In most versions, BASIC is an unstructured language. The original Basic was easy to learn allowing computer users to write simple programs within a few minutes.

Basic uses five major categories of statements:

- Arithmetical statements allow users to use Basic like a calculator
- Input/ Output statements, including READ, DATA, INPUT and PRINT
- Control statements including GOTO, IF-THEN, FOR, NEXT and END control the sequence of instructions executed by the computer
- Other statements help document Basic programs and set up data dimensions respectively
- System Commands tell the operating system how to work with Basic programs

RUN means execute a program

LIST directs the computer to display a Basic program.

### 1. Fill in the gaps necessary words or expressions:

1. First machines were ..... by flipping toggle switches and ..... .
2. The programming languages fall into ..... .
3. They are comprised of ..... and ..... .
4. .... are powerful programming tools.
5. Machine-dependent means ..... .
6. A high-level language is a language in which ..... .
7. .... is an expression of instruction in a programming language.
8. .... allows programmers to calculate complex formulas with a few source code instructions.
9. .... stands for ALGOritmic Language.
10. Basic uses ..... .

### 2. Fill in the prepositions:

1. Programming has been ..... us for over 40 years.
2. People began searching ..... a better, faster way to issue instructions to the computer.
3. They offer programmers greater ease ..... writing instructions.
4. Assembly code ..... a Prime mini won't work ..... a Digital mini.
5. Assembly languages were the first bridge ..... the English Language and the computer's binary language.
6. A statement translates ..... one or more instructions ..... the machine language level.
7. System Commands tell the operating system how to work ... Basic programs.

### 3. Find the synonyms to the following words:

to execute, a tool, to allow, to preserve a notation, to issue, to differ

### 5. Give appropriate definition of the following terms:

1. Programming languages
2. Assembly Language

3. Cobol
4. Algol
5. Basic

**6. Give the situation from the text in which the following words and expressions are used:**

- 1) for over 40 years
- 2) slow, awkward process
- 3) three general categories
- 4) a large amount of direct control
- 5) machine-dependent
- 6) to develop operating systems
- 7) combine several machine language instructions
- 8) a set of statements
- 9) a few code instructions
- 10) write code efficiently

**7. Answer the questions:**

1. How were the first computers programmed?
2. What is an example of assembly language?
3. What does the term machine-dependent mean?
4. What is an assembly language primary used for?
5. What is a high-level language?
6. What does it combine?
7. What is a statement/syntax?
8. When was FORTRAN created? What is Fortran?
9. When was Cobol created? What is Cobol?
10. How many sections are Cobol separated into?

**4. Порядок выполнения работы**

Выполнить задания , изучить материал

**5. Содержание отчета**

конспект

## Практическое занятие 5. Понятие сети

- 6. Цель работы:** Развитие монологической речи, умение подготовить высказывание по теме «Понятие сети»

**7. Задачи работы:**

- ввести лексические единицы по теме “ Понятие сети “ Современные технологии коммуникации.”, используя необходимые лексические единицы
- освоить навыки составления презентаций

**3. Подготовка к работе**

Повторение слов по теме “ Понятие сети»

A network is a group of computers and other devices, such as printers and modems, connected to each other. This enables the computers to effectively share data and resources. The concept of



sharing resources over a network is called networking. The computers in a network can share data, messages, graphics, printers, fax machines, modems, and other hardware and software resources.

In a **Peer-to-Peer Network**, there are no dedicated servers, and there is no hierarchy among the computers. All the computers are equal and therefore are known as *peers*. Each computer functions as both a **client** and a **server**. And there is no administrator responsible for the entire network. The user at each computer determines what **data** on that computer is **shared** on the net-

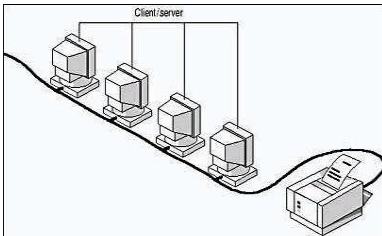

work. In a peer-to-peer network, all computers are considered equal; they all have the same abilities to use the **resources** available on the network. Computers are not dedicated to function as servers. They use the network to share resources among the independent peers. The computer whose applications are required by the

other networked computers functions as a server. The other computers function as clients. Therefore, a dedicated administrator is not assigned for network management. A peer-to-peer network is a small group of people using a network and performing similar tasks, which necessitates the sharing of resources. The users of each computer plan and control the security of their resources. The users determine the resources on their computers, which can be shared on the network. The shared network resources, such as disk space, printers or faxes, can be used by anyone who has access to the network. This is possible only if the shared network resources are not password protected. A peer-to-peer network does not support a central login process. Peer-to-peer networks are relatively simple. The users handle administration.

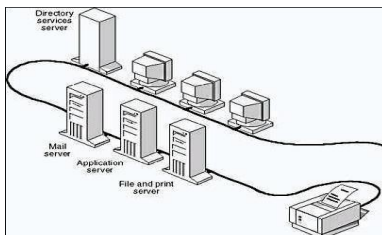

A dedicated server is one that functions only as a server and is not used as a client or workstation. **Server Based Networks** have become the standard models for networking. In a server-based network, clients rely on the services that the server provides, such as file storing and printing. Client computers are generally less power-

ful than server computers. A server-based network using network operating system is that the networks are organized into **domains**. In server-based net-

works, a network administrator centrally manages the resource security. The administrator defines and manages user access to network resources.

**Local Area Network (LAN)** is a network connected to each other in a single location.

**Wired Local Area Network** is the simplest network in which computers are connected to each other by cables.

A LAN is also called a *node*. A LAN is characterized by three primary attributes: **topology, medium,**

**protocols.** Wireless local-area networks have the advantage of expandability. The topology and the medium used on a particular network are specified by the protocol.

There are a number of ways in which nodes can communicate over a network. The simplest is to establish a dedicated link between the transmitting and receiving stations. This technique is known as circuit switching. A better way of communicating is to use a technique known as **packet switching**, in which a dedicated path is not reserved between the source and the destination.

**Wireless Local Area Network** refers to technology that enables two or more computers to communicate using standard network protocols, but without network

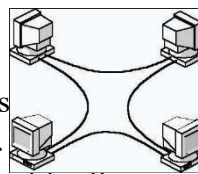

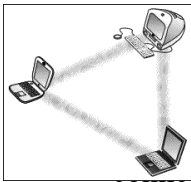

cabling. Each computer can communicate directly with all of the other wireless enabled computers. A wireless network can also use an access point, or base station. In this type of network the access point acts like a *hub*, providing connectivity for the wireless computers. It can

connect the wireless LAN to a wired LAN allowing wireless computer access to LAN or existing Internet Connectivity.

There are two types of access points (HAP) offer complete support but check your requirements carefully.

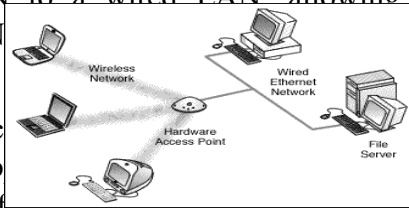

**Software Access Points** which run on a computer equipped with a wireless network interface card as used in peer-to-peer wireless network. The software routers that can be used as a basic Software Access Point, and include features not commonly found in hardware solutions.

Wireless networking offers a cost-effective solution to users with difficult physical installations. Businesses with more than one location but separated by public thoroughfares requires two access points. Each access point connects its own LAN to

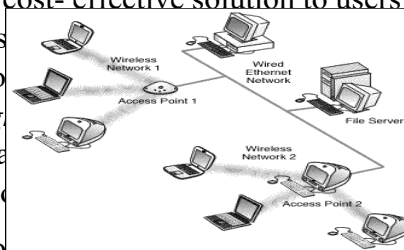

The wireless connection allows the two access points to communicate with each other, and therefore interconnect the two LAN's. Each access point has a finite range within which a wireless connection can be maintained between the client computer and the access point. The actual distance varies depending upon the environment. Also it should be noted that when operating at the limits of range the performance may drop, as the quality of connection *deteriorates* and the system compensates. Typical indoor ranges are 150-300 feet, but can be shorter if the building construction interferes with radio transmissions. Longer ranges are possible, but performance will degrade with distance. Outdoor ranges are quoted up to 1000 feet, but again this depends upon the environment.

In most cases, separate access points are interconnected via a wired LAN, providing wireless connectivity in specific areas such as offices or rooms, but connected to a main wired LAN for access to network resources, such as file servers. If a single area is too large to be covered by a single access point, then multiple access points or extension points can be used.

When using multiple access points, the wireless area should overlap in a seamless area for users to move and "roaming." A wireless computer can move from one access point to another, with the software

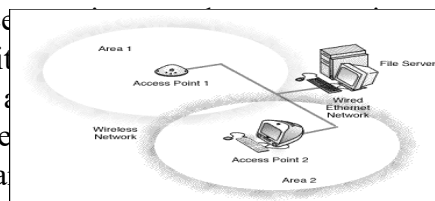

and hardware maintaining a steady network connection by monitoring the signal strength from in-range access points and locking on to the one with the best quality.

Some access point configurations require security authentication when swapping access points, usually in the form of a password dialog box. Access points are required to have overlapping wireless areas to achieve this. *A user can move from Area 1 to Area 2 transparently. The*

*Wireless networking hardware automatically swaps to the Access Point with the best signal.*

Some manufacturers produce extension points, which act as wireless relays, extending the range of a single access point. Multiple

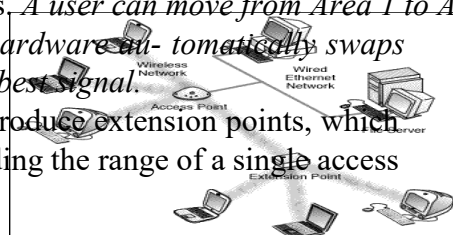

extension points can be strung together to provide wireless access to far away locations from the central access point.

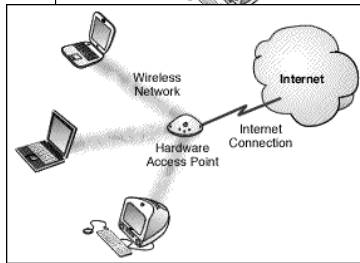
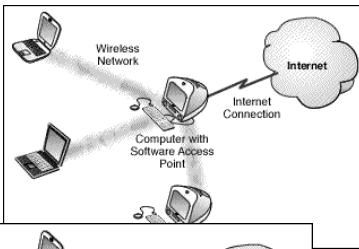

To share an Internet connection across a LAN you need two things: an Internet sharing hardware device or software program and a LAN. Any computer equipped with a wireless network card running suitable Internet sharing software can be used as a software access point. A number of

vendors offer hardware access points.

A hardware access point may provide Internet Sharing capabilities to Wired LAN computers, but does not usually provide much flexibility beyond very simple configurations.

If an existing wired LAN already has an Internet connection, then the hardware access points simply connect to LAN and allow

wireless computers to access the existing Internet connection in the same way as wired LAN computers.

Wireless communications obviously provide potential security issues, as an intruder does not need physical access to the traditional wireless

access to data communications cannot be restricted by simple scanners, short wave the

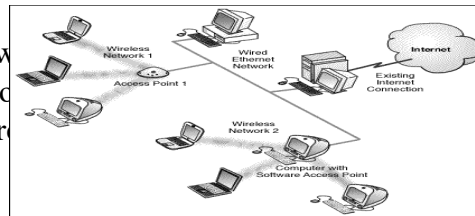

common misconception that wireless communications cannot be *eavesdropped* at all. However, eavesdropping is possible using specialist equipment.

To protect against any potential security issues, 802.11 wireless communications have a function called **WEP**. Wireless networking hardware requires the use of underlying technology that deals with radio frequencies as well as data transmission. The most widely used standard is 802.11 produced by the Institute of Electrical and Electronic Engineers (IEEE). This is a standard defining all aspects of Radio Frequency Wireless networking.

It should also be noted that traditional Virtual Private Networking (VPN) techniques will work over wireless networks in the same way as traditional wired networks.

1. Find and learn Russian equivalents for the following words and expressions:

1) dedicated server	a)
2) peer-to-peer network	b)
3) circuit switching	c)
4) packet switching	d)
5) node	e)
6) receiving station	f)
7) dedicated path	g)
8) wireless network access	h)

9) intruder	i)
-------------	----

**2. Find and learn English equivalents for the following words and expressions:**

1) сетевой компьютер, использующий ресурсы сервера)	a)
2) серверная сеть	b)
3) передающая станция	c)
4) точка доступа	d)
5) беспроводная передача данных	e)
6) экономичное (техническое) решение	f)
7) прямое обращение	g)
8) режим поддержания постоянной связи при перемещениях абонента;	h)
9) коротковолновый приемник	i)

**Clients**

**3. Translate the following sentences into Russian.**

- 1) There are ways to extend the basic operating range of Wireless communications, by using more than a single access point or using a wireless relay /extension point.
- 2) Multiple access points can be connected to a wired LAN, or sometimes even to a second wireless LAN if the access point supports this.
- 3) The reliable and cost-effective test solution for military computer devices with PCI, ISA and MULTIBUS I bus based on StarFabric technique.
- 4) In wireless telecommunications, roaming is a general term referring to the extension of connectivity service in a location that is different from the home location.
- 5) I would like to expand the range of my @home hotspot with seamless handoff between my access points without dropping a call.

**4. Translate the following sentences into English.**

1. Коммутация каналов — это наиболее известная технология, используемая для построения сети связи.

2. В компьютерной сети, беспроводная точка доступа — это беспроводная базовая станция, предназначенная для обеспечения беспроводного доступа к уже существующей сети при помощи сертификата Wi-Fi.

3. Необходимо ограничить несанкционированный доступ к учётной записи пользователя.

4. Этот крошечный коротковолновый приемник отличается поразительным диапазоном чувствительности от 40 кГц до 30 МГц, избирательностью и способностью подавлять помехи.

5. Узнайте больше о прямом обращении к многосервисной мобильной платформе, и что внутренние и внешние пользователи вашей профессиональной сети говорят об этом.

## SPEAKING

8. Answer the following questions.

1. Why are Peer-to-peer networks relatively simple?
2. What does it mean that the users handle administration?
3. What are the advantages and disadvantages of a peer-to-peer network?
4. What are domain controllers?
5. What are the advantages and disadvantages of Server Based Networks?

9. **Prepare a presentation on the topic being discussed.**

## Практическое занятие 6. Сети и их типы.

1. **Цель работы:** Развитие монологической речи, умение подготовить высказывание по теме «Сети и их типы.»

2. **Задачи работы:**

- ввести лексические единицы по теме “ Сети и их типы. ”
- освоить составление монологического высказывания по теме “ Современные технологии коммуникации.”, используя необходимые лексические единицы
- освоить навыки составления презентаций

3. **Подготовка к работе**

Повторение слов по теме “ Сети и их типы.»

## THE INTERNET & WORLD WIDE WEB

1. Match the words with their definitions:

1) snarky(adj.)	['sna:kɪ]	a) present, appearing, or found everywhere
2) intertwine (v.) with obj.	[,ɪntə'twain]	b) increase very steeply or rapidly

3) launch (v.)	[lɔːnʃ]	c) sharply critical (inf., AmE.)
4) a missile	['mɪsaɪl]	d) to be closely connected
5) skyrocket (v.)	['skaɪ,rɒkɪt]	e) a weapon that is self-propelled or directed  by remote control, carrying conventional or nuclear explosive
6) ubiquitous (adj.)	[ju:'bɪkwɪtəs]	f) send (a missile, satellite, or spacecraft) on  its course
7) harassment (n.)	['hærəsmənt ], [hə'ræsmənt]	g) behaviour which is intended to trouble or  annoy someone

— Before you read

**2. Discuss with your partner the following questions.**

- What do you know about the Internet and the World Wide Web?
- What are the reasons for using the Internet?

**3. Skim the text to check your ideas.**



THE INTERNET OR WWW?



The Internet has become so *ubiquitous* it's hard to imagine life without it. It's equally hard to imagine a world where "www" isn't the prefix of many of our online activities. But just because the **Internet** and the World Wide Web are firmly *intertwined with* each other, it doesn't mean they're synonymous. Let's go back to when it all began.

Mention the history of the Internet to a group of people, and chances are someone will make a *snarky* comment about Al Gore claiming to have in-

vented it. Gore actually said that he "took the initiative in creating the Internet". He promoted the Internet's development both as a senator and as vice president of the United States. So how did the Internet really get started? Believe it or not, it all began with a satellite. It was 1957 when the then Soviet Union *launched* Sputnik, the first man-made satellite. Americans were shocked by the news. The Cold War was at its peak, and the United States and the Soviet Union considered each other enemies. If the Soviet Union could launch a satellite into space, it was possible it could launch a *missile* at North America. President Dwight D. Eisenhower created the **ARPA** in 1958 as a direct response to Sputnik's launch. ARPA's purpose was to give the United States a technological edge over other countries. One important part of ARPA's mission was computer science. In the 1950s,

computers were enormous devices that filled entire rooms. They had a fraction of the power and processing ability you can find in a modern PC. Many computers could only read magnetic tape or punch cards, and there was no way to network computers together. ARPA aimed to change that. It enlisted the help of the company Bolt, Beranek and Newman (BBN) to create a computer network. The network had to connect four computers running on four different operating systems. They called the network ARPANET. By October 29, 1969, the first ARPANET network connection between two computers was launched -- and promptly crashed. But happily, the second time around was much more successful and the Internet was born. More and more computers were added to this ever-increasing network and the megalith we know today as the Internet began to form. Although other groups were working on ways to network computers, ARPANET established the protocols used on the Internet today. Moreover, without ARPANET, it may have taken many more years before anyone tried to find

ways to join regional networks together into a larger system. In 1973, engineers began to look at ways to connect ARPANET to the PRNET. A packet radio network connects computers through radio transmitters and receivers. Instead of sending data across phone lines, the computers use radio waves. It took three years, but in 1976 engineers successfully connected the two networks. Technicians joined the SATNET to the other two networks in 1977. They called the connection between multiple networks inter-networking, or the Internet for short. Other early computer networks soon joined. They included **USENET**, **BITNET**, **CSNET** and **NSFNET**. In 1990, Tim Berners-Lee developed a system designed to simplify navigation on the Internet. In time, this system became known as the World Wide Web. It didn't take long for some people to mistakenly identify the Internet and the Web as the same thing. The Internet is a global interconnection of computer networks; the World Wide Web is a way to navigate this massive network. In sailing terms, it's like comparing an ocean to a ship.

Most early Internet users were government and military employees, graduate students and computer scientists. Using the World Wide Web, the Internet became much more accessible. Colleges and universities began to connect to the Internet, and businesses soon followed. The creation of the World Wide Web came with the help of a man named Tim Berners-Lee. In 1990, he developed the backbone of the World Wide Web -- the **HTTP**. People quickly developed browsers which supported the use of HTTP and with that the popularity of computers *skyrocketed*. In the 20 years during which ARPANET ruled the Internet, the worldwide network grew from four computers to more than 300,000. By 1992, more than a million computers were connected -- only two years after HTTP was developed.

You might be wondering at this point what exactly HTTP is -- it's simply the widely used set of rules for how files and other information are transferred between computers. So what Berners-Lee did, in essence, was determine how computers would communicate with one another. For instance, HTTP would've come into play if you clicked the source link in the last paragraph or if you typed the `http://www.iseu.by` **URL** into your browser to get to our university page. But don't get this confused with Web page programming languages like **HTML** and **XHTML**. We use those to describe what's on a page, not to communicate between sites or identify a Web page's location.

So, if there is any difference between `www` and the Internet? To answer this question, let's look at each element. Simply, the Internet is a network of networks -- and there are all kinds of networks in all kinds of sizes. You may have a computer network at your work, at your university or even one at your house. These networks are often connected to each other in different configurations, which is how you get groupings such as LANs and regional networks. Your cell phone is also on a network that is considered part of the Internet, as are many of your other electronic devices. And all these separate networks -- added together -

- are what constitute the Internet. Even satellites are connected to the Internet.

The World Wide Web, on the other hand, is the system we use to access the Internet. The Web isn't the only system out there, but it's the most popular and widely used. (Examples of ways to access the Internet without using HTTP include e-mail and instant messaging.) As mentioned on the previous page, the World Wide Web makes use of hypertext to access the various forms of information available on the world's different networks. This allows people all over the world to share knowledge and opinions. We typically access the Web through browsers, like Internet Explorer and Mozilla Firefox. By using browsers like these, you can visit various Web sites and view other online content.

So another way to think about it is to say the Internet is composed of the machines, hardware and data; and the World Wide Web is what brings this technology to life.

## LANGUAGE

4. Find and learn Russian equivalents for the following words and expressions:

1) instant messaging	a)
2) ever-increasing network	b)
3) online content	c)
4) allotment	d)
5) online defamation	e)

5. Find and learn English equivalents for the following words and expressions:

1) программа просмотра Web, навигатор	a)
2) межсетевой обмен, межсетевое взаимодействие	b)
3) протокол передачи гипертекстовых файлов	c)
4) экспериментальная сеть	d)
5) нарушение авторского права	e)

6. Find and learn English and Russian the definitions for the following abbreviations

1) ARP	a)
2) ARPANET	b)
3) PRNET	c)
4) SATNET	d)



5) USENET	e)
6) BITNET	f)
7) CSNET	g)
8) NSFNET	h)
9) WWW	i)
10) HTTP	j)
11) URL	k)

### ARPA

The U.S. Defense Department's ARPA (Advanced Research Projects Agency) sponsored a study of a "co-operative network of time-sharing computers." A testbed network was begun by connecting a TX-2 mini-computer at MIT via phone line to a computer at System Development Corporation in Santa Monica, California.

### BITNET

In 1981, a network called BITNET ("Because It's Time Network") began to link academic institutions worldwide.

### CSNET

The Computer Science Network was a computer network that began operation in 1981 in the United States. Its purpose was to extend networking benefits, for computer science departments at academic and research institutions that could not be directly connected to ARPANET (which was the predecessor to the Internet), due to funding or authorization limitations. It played a significant role in spreading awareness of, and access to, national networking and was a major milestone on the path to development of the global Internet. CSNET was funded by

the National Science Foundation for an initial three-year period from 1981 to 1984.

### NSFNET

In 1986, the National Science Foundation funded, which provides high-speed Internet connections to link universities and research institutions. **HTTP**

A protocol used to request and transmit files, especially webpages and webpage components, over the Internet or other computer network. **Internet service provider (ISP)**

An Internet service provider is any organization that provides access to the Internet. While nonprofit organizations such as universities and government agencies can be considered to be ISPs, the term is generally applied to a commercial, fee-based service. Typically, a user is given an account that is accessed by logging in through the operating system's Internet connection facility by supplying a user ID and password. Once connected, the user can run Web browsers, e-mail clients, and other programs that are designed to work with an Internet connection. Most personal ISP accounts include a small allotment of server space that users can use to host their personal Web pages. There are

generally extra charges for larger allotments of space, for sites that generate high traffic, and for commercial sites. Business-oriented ISPs typically provide a more generous starting allotment along with more extensive technical support and more reliable and higher-capacity servers that are managed 24 hours a

day. People entering the business today strive to provide added-value services such as superior Web page hosting facilities, hosting blogs or wikis, or to focus on specialized services for particularly industries (such as real estate). Today's ISPs also face a variety of legal challenges, including customer privacy vs. the war on terrorism, responsibility for copyright infringement, and possible liability for online defamation, *harassment*, or worse.

## HTML

Several markup languages have been devised for specifying the organization or format of documents. Today the most commonly known markup language is the Hypertext Markup Language (see `html`, `dhtml`, and `xhtml`), which is the organizational “glue” of the Web (see World Wide Web). HTML is primarily concerned with rendering (displaying) documents. It describes structural features of documents (such as headers, sections, tables, and frames), but it does not really convey the structure of the information within the document. Further, HTML is not extensible — that is, one can't define one's own tags and use them as part of the language. XML, or Extensible Markup Language, is designed to meet both of these needs. In effect, while HTML is a descriptive coding scheme, XML is a scheme for creating data definitions and manipulating data within documents. (XML can be viewed as a subset of the powerful and generalized SGML, or Standard Generalized Markup Language.)

**URL**

An Internet address (for example, `http://www.hmco.com/trade/`), usually consisting of the access protocol (`http`), the domainname (`www.hmco.com`), and optionally the path to a file or resource residing on that server (`trade`).

## USENET

In 1979, Unix users Tom Truscott, Jim Ellis, and Steve Bellovin developed a program to exchange news in the form of files copied between the Duke University and University of North Carolina computer systems. This gradually grew into USENET (or netnews), providing thousands of topical newsgroups.

### 7. Translate the following sentences into Russian.

1. Instant messaging (IM) is a type of online chat, which offers real-time text transmission over the Internet.

2. Thus, XML documents can be properly rendered by browsers, while applications that are XML-enabled (or that use XML-aware ActiveX controls or similar Java facilities, for example) can parse the XML and identify the data structures and elements in the document.

3. business-oriented ISPs typically provide more generous starting allotment along with more extensive technical support and more reliable and higher-capacity servers that are managed 24 hours a day.

4. The tort of cyber defamation is considered to be the act of defaming, insulting, offending or otherwise causing harm through false statements.

5. MoteLab provided a public, long-lived testbed for development and testing of sensor network applications via an intuitive web-based interface.

6. The ever-increasing body of medical and scientific information, which becomes available through professional publications each year, makes it virtually impossible for the average health professional to keep up with the latest knowledge or developments.

### 8. Translate the following sentences into English.

1. Как правило, существуют дополнительные наценки за больший объем выделяемого

пространства, за сайты, генерирующие высокий сетевой трафик и коммерческие сайты.

2. Типичный полигон может включать в себя программное и аппаратное обеспечение, а также сетевые компоненты.

3. Нарушение авторских прав происходит, когда произведение, охраняемое авторским правом, воспроизведено, распространено, представлено перед аудиторией или переработано без разрешения правообладателя.

4. Существуют два основных типа клеветы: пасквиль или письменная клевета, злословие или устные клеветнические измышления.

5. Веб-контент это текстовой, визуальный или звуковой ресурс (содержимое) с которым встречаются пользователи во время работы с сайтом.

9. Answer the following questions and think over five more questions, which you could ask your partner about.

1. Is there any fundamental difference between the Internet and the World Wide Web?

2. Why it's so easy for us to link them together in our minds?

3. What are the advantages and disadvantages of our ever-increasing use of computer technology?

**10. Prepare a presentation on the topic being discussed.**

#### **4. Порядок выполнения работы**

Выполнить задания , изучить материал

#### **5. Содержание отчета**

конспект

## **Практическое занятие 7. Проводные и беспроводные компьютерные сети.**

**1. Цель работы:** Развитие монологической речи, умение подготовить высказывание по теме «Проводные и беспроводные компьютерные сети..»

#### **2. Задачи работы:**

- ввести лексические единицы по теме “ Проводные и беспроводные компьютерные сети. ”
- освоить составление монологического высказывания по теме “ Современные технологии коммуникации.”, используя необходимые лексические единицы
- освоить навыки составления презентаций

#### **3. Подготовка к работе**

Повторение слов по теме “ Проводные и беспроводные компьютерные сети.»

### **Network**

The Internet is a huge network of computers spanning this planet and is now started to bring in the surrounding area like space. Some computers like servers share data, others just surf the web as clients downloading the data. Public Internet began in the late 70's. In the 70's web users used an interface called telnet, but now that program is mainly obsolete. Telnet is most widely deployed in accessing college email accounts.

The Internet is very helpful, because it's a huge database of knowledge, from the pictures of family trips to an analysis of quantum mechanics. Everyone should have the Internet because of its near instantaneous communication and huge wealth of knowledge. But how to go on the Internet and do a search for information we need. There are two ways to do it.

The first is when you know an internet address of data you need and the second one is when you try to find information you need by using a search program. In the beginning we have got to enter any browser you like. It

could be an Internet Explorer, Netscape Navigator or Opera, etc. If we have a broadband connection, we connect to the Internet at once. If not, we have to set up and connect to our dial-up service. Finally, if we want to find some information in the Internet, we are to type an address of this data in the browser we use or simply use the existing search-programs such as the google search program, rambler search program, yandex search program or yahoo search program.

They are very simple and popular networks of sites. In these programs we can just type the word or name of thing, we would like to find and then press enter. A search program solves this problem. We get our results in the same window. After we get our results, we simply choose whatever site best matches our query or keep searching.

Besides data, one can get from the Internet, we can also send and receive e-mail or electronic mail. This internet service is cheaper than ordinary mail and much quicker. It is becoming popular day by day. We can get some news from the Internet, because there are many informational servers in the web.

### **1. Find English equivalents in the text:**

огромная сеть компьютеров,  
обмениваются данными,  
заняться поиском нужной нам информации,  
использовать существующие поисковые программы,  
популярные сети сайтов,  
соответствует нашему запросу,  
мы также можем отправлять и получать электронную почту.

### **2. Fill in the gaps with the following words:**

**explorer, e-mail, network, cheaper, knowledge.**

1. The Internet is a huge ... of computers spanning this planet.
2. In the beginning we have got to enter any browser you like. It could be an Internet ... , Netscape Navigator or Opera, etc.
3. The Internet is very helpful, because it's a huge database of ... , from the pictures of family trips to an analysis of quantum mechanics.
4. Besides data, one can get from the Internet, we can also send and receive ... or electronic mail.
5. This internet service is ... than ordinary mail and much quicker.

### **3. Write a short summary of the text (15-20 sentences).**

Write a short opinion on the problem of how the internet influences modern life.

#### **4. Порядок выполнения работы**

Выполнить задания , изучить материал

#### **5. Содержание отчета**

конспект

## **Практическое занятие 8. Топология беспроводных и проводных сетей.**

1. **Цель работы:** Развитие монологической речи, умение подготовить высказывание по теме «Топология беспроводных и проводных сетей.»

## 2. Задачи работы:

- ввести лексические единицы по теме “ Топология беспроводных и проводных сетей...”
- освоить составление монологического высказывания по теме “ Современные технологии коммуникации.”, используя необходимые лексические единицы
- освоить навыки составления презентаций

## 3. Подготовка к работе

Повторение слов по теме “ Топология беспроводных и проводных сетей.»

## Cloud Computing

### I. Look at the following quotes about cloud computing. Do you agree with them? Why (not)?

*A lot of people are jumping on the [cloud] bandwagon, but I have not heard two people say the same thing about it. There are multiple definitions out there of “the cloud.”*

Andy Isherwood, quoted in ZDnet News, December 11, 2008

*The interesting thing about Cloud Computing is that we’ve redefined Cloud Computing to include everything that we already do. . . . I don’t understand what*

*we would do differently in the light of Cloud Computing other than change the wording of some of our ads.*

Larry Ellison, quoted in the Wall Street Journal, September 26, 2008

### II. Study the text and answer the question “Why is cloud computing an old idea?”.

#### **To Cloud Computing: An Old Idea Whose Time Has (Finally) Come**

Cloud Computing is a new term for a long held dream of computing as a utility, which has recently emerged as a commercial reality.

Cloud Computing refers to both the applications delivered as services over the Internet and the hardware and systems software in the datacenters that provide those services. The services themselves have long been referred to as Software as a Service (SaaS), so we use that term. The datacenter hardware and software is what we will call a Cloud.

When a Cloud is made available in a pay-as-you-go manner to the public, we call it a Public Cloud; the service being sold is Utility Computing. Current examples of public Utility Computing include Amazon Web Services, Google AppEngine, and Microsoft Azure. We use the term Private

Cloud to refer to internal datacenters of a business or other organization that are not made available to the public. Thus, Cloud Computing is the sum of SaaS and Utility Computing, but does not normally include Private Clouds. We'll generally use Cloud Computing, replacing it with one of the other terms only when clarity demands it.

The advantages of SaaS to both end users and service providers are well understood. Service providers enjoy greatly simplified software installation and maintenance and centralized control over versioning; end users can access the service “anytime, anywhere”, share data and collaborate more easily, and keep their data stored safely in the infrastructure. Cloud Computing does not change these arguments, but it does give more application providers the choice of deploying their product as SaaS without provisioning a datacenter: just as the emergence of semiconductor foundries gave chip companies the opportunity to

Design and sell chips without owning a fab, Cloud Computing allows deploying SaaS—and scaling on demand—without building or provisioning a datacenter. Analogously to how SaaS allows the user to offload some problems to the SaaS provider, the SaaS provider can now offload some of his problems to the Cloud Computing provider.

From a hardware point of view, three aspects are new in Cloud Computing:

1. The illusion of infinite computing resources available on demand, thereby eliminating the need for Cloud Computing users to plan far ahead for provisioning;
2. The elimination of an up-front commitment by Cloud users, thereby allowing companies to start small and increase hardware resources only when there is an increase in their needs; and
3. The ability to pay for use of computing resources on a short-term basis as needed (e.g., processors by the hour and storage by the day) and release them as needed, thereby rewarding conservation by letting machines and storage go when they are no longer useful.

While the attraction to Cloud Computing users (SaaS providers) is clear, who would become a Cloud Computing provider, and why? To begin with, realizing the economies of scale afforded by statistical multiplexing and bulk purchasing requires the construction of extremely large datacenters.

Building, provisioning, and launching such a facility is a hundred-million-dollar undertaking. However, because of the phenomenal growth of Web services through the early 2000's, many large Internet companies, including Amazon, eBay, Google, Microsoft and others, were already doing so. Equally important, these companies also had to develop scalable software infrastructure (such as MapReduce, the Google File System, BigTable, and Dynamo [16, 20, 14, 17]) and the operational expertise to armor their datacenters against potential physical and electronic attacks.

Therefore, a necessary but not sufficient condition for a company to become a Cloud Computing provider is that it must have existing investments not only in

very large datacenters, but also in large-scale software infrastructure and operational expertise required to run them.

The long dreamed vision of computing as a utility is finally emerging. The elasticity of a utility matches the need of businesses providing services directly to customers over the Internet, as workloads can grow (and shrink) far faster than 20 years ago. It used to take years to grow a business to several million customers – now it can happen in months.

From the cloud provider's view, the construction of very large datacenters at low cost sites using commodity computing, storage, and networking uncovered the possibility of selling those resources on a pay-as-you-go model below the costs of many medium-sized datacenters, while making a profit by statistically multiplexing among a large group of customers. From the cloud user's view, it would be as startling for a new software startup to build its own datacenter as it would for a hardware startup to build its own fabrication line. In addition to startups, many other established organizations take advantage of the elasticity of Cloud Computing regularly, including newspapers like the Washington Post, movie companies like Pixar, and many universities.

*(Abridged from "Above the clouds: a Berkeley view of cloud computing"*  
*<http://www.eecs.berkeley.edu/Pubs/TechRpts/2009/EECS-2009-28.pdf>)*

**III.** Look through the text again and give Russian equivalents to the following words.

Utility, scale (v), Public cloud, Utility computing, semiconductor, application, Software as a Service (SaaS), on demand, service provider, multiplex, maintenance, offload, Private cloud, version (v), bulk purchase.

Now make up 3 sentences of your own using these words.

**IV.** Make pairs of words with similar meaning.

Commitment, short-term, current, appear, thereby, eliminate, enough, spread out, limitless, old desire, available, inner, reinforce, require, accessible, actual, undertaking, expertise, remove, proficiency, sufficient, emerge, by means of that, demand, up-front, deploy, definite, obligation, infinite, short-run, internal, long- held dream, reward, project.

V. Find sentences in the text beginning with the following words and phrases, translate them into Russian.

*To begin with... .*

*Analogously... .*

*In addition to ... .*

*From a hardware point of view ... .*

*Therefore ... .*

Now using these words and phrases make written translation of the sentences given below.

1. Аналогично, облачные версии деловых и коммуникационных приложений позволят даже малым компаниям воспользоваться инструментами, больше характерными для корпораций.
2. Таким образом, облачные вычисления – это комбинация давно существующих идей и решений, обеспечивающая им новое качество.
3. Для начала создадим Частное облако, настроим сетевую адресацию и запустим виртуальный сервер, который будет выполнять роль маршрутизатора.
4. С точки зрения поставщика, благодаря объединению ресурсов и непостоянному характеру потребления со стороны потребителей, облачные вычисления позволяют экономить на масштабах, используя меньшие аппаратные ресурсы, чем требовались бы при выделенных аппаратных мощностях для каждого потребителя, а за счёт автоматизации процедур модификации выделения ресурсов существенно снижаются затраты на абонентское обслуживание.

VI. Focus on grammar. Look at the sentences from the text and translate them paying attention to the words in bold. Comment on the use and meaning of these words.

- Computing does not change these arguments, but it **does** give more application providers the choice of deploying their product as SaaS without provisioning a datacenter... .
- ... thereby eliminating the need for Cloud Computing users to plan **far** ahead for provisioning. ... workloads can grow (and shrink) **far** faster than 20 years ago.

Complete the sentences.

1. – You said you would phone me! – I ... you! But you didnt answer. – Ok, I didnt phone you, but I send you a text message.
2. She look good in that dress.



3. This book is more interesting than that one.
4. I never understand what he saw in her.
5. He is taller than his brother.

**VII.** Answer the questions about cloud computing basing on the text and your knowledge.

1. Name the main features of cloud services.
2. How many types of deployment models are used in the cloud?
3. What is the difference between Private cloud and Public cloud?
4. What are the advantages of SaaS for end users?
5. What are the advantages of SaaS for service providers?
6. Explain the essence of SaaS, PaaS and IaaS.
7. What is the biggest obstacle and opportunity for growth of cloud computing?
8. What prevented from realization of the idea of cloud computing before?
9. In what way do you use cloud computing?
10. Do you use cloud storage? If yes, which providers do you prefer? Why?

**VIII.** Порядок выполнения работы

Выполнить задания , изучить материал

**IX.** Содержание отчета

конспект

**Практическое занятие 9. Физическая передающая среда (коаксиальный кабель, витая пара, оптоволокно).**

**I. Цель работы:** Развитие монологической речи, умение подготовить высказывание по теме “ Физическая передающая среда (коаксиальный кабель, витая пара, оптоволокно)..”

**II. Задачи работы:**

- ввести лексические единицы по теме “ Физическая передающая среда (коаксиальный кабель, витая пара, оптоволокно).. ”
- освоить составление монологического высказывания по теме “ Современные технологии коммуникации.”, используя необходимые лексические единицы
- освоить навыки составления презентаций

**3. Подготовка к работе**

Повторение слов по теме “ Физическая передающая среда (коаксиальный кабель, витая пара, оптоволокно)..”

## **Grid Computing**

*1. Before reading the text try to explain what grid computing is.*

*2. Read the text and see if your definition of grid computing was right.*

### **Clouds, Grids, and Distributed Systems**

Grid computing provides key infrastructure for distributed problem solving in dynamic virtual organizations. It has been adopted by many scientific projects, and industrial interest is rising rapidly. However, Grids are still the domain of a few highly trained programmers with expertise in networking, high-performance computing, and operating systems. In particular, the number of users lags behind the initial forecasts laid out by proponents of grid technologies. This underachievement may have led to claims that the grid concept as a whole is on its way to being replaced by Cloud computing and various X-as-a-Service approaches. With cloud computing, companies can scale up to massive capacities in an instant without having to invest in new infrastructure, train new personnel, or license new software. Cloud computing is of particular benefit to small and medium-sized businesses who wish to completely outsource their data-center infrastructure, or large companies who wish to get peak load capacity without incurring the higher cost of building larger data centers internally. The consumer does not own the infrastructure, software, or platform in the cloud. He has lower upfront costs, capital expenses, and operating expenses. He does not care about

how servers and networks are maintained in the cloud.

Cloud computing evolves from grid computing and provides on-demand resource provisioning. Grid computing may or may not be in the cloud depending on what type of users are using it.

Grid computing requires the use of software that can divide and farm out pieces of a program as one large system image to several thousand computers. One concern about grid is that if one piece of the software on a node fails, other pieces of the software on other nodes may fail. This is alleviated if that component has a failover component on another node, but problems can still arise if components rely on other pieces of software to accomplish one or more grid computing tasks. Large system images and

associated hardware to operate and maintain them can contribute to large capital and operating expenses.

### Similarities and differences

Cloud computing and grid computing are scalable. Scalability is accomplished through load balancing of application instances running separately on a variety of operating systems and connected through Web services. CPU and network bandwidth is allocated and de-allocated on demand. The system's storage capacity goes up and down depending on the number of users, instances, and the amount of data transferred at a given time.

Both computing types involve multitenancy and multitask, meaning that many customers can perform different tasks, accessing a single or multiple application instances. Sharing resources among a large pool of users assists in reducing infrastructure costs and peak load capacity. Cloud and grid computing provide service-level agreements (SLAs) for guaranteed uptime availability of, say, 99 percent. If the service slides below the level of the guaranteed uptime service, the consumer will get service credit for receiving data late.

The storage computing in the grid is well suited for data-intensive storage, however it is not economically suited for storing objects as small as 1 byte. In a data grid, the amounts of distributed data must be large for maximum benefit. A computational grid focuses on computationally intensive operations.

Clouds and Grids share a lot commonality in their vision, architecture and technology, but they also differ in various aspects such as security, programming model, business model, compute model, data model, applications, and abstractions. (*Abridged from <http://www.ibeehosting.com/blog/what-is-the-difference-between-cloud-computing-and-grid-computing.html>*)

### 3. Find words in the text that have similar meaning.

Focus; quickly; an addressable point on a network; execute; be unable to keep up; project; prediction; redundancy within computer network; supporter; cause; upon request; arrange for work to be done by others; the difference between the highest and lowest frequencies of a transmission channel; facilitated; amounts paid for goods and services that may be currently tax deductible; techniques which aim to spread tasks among the processors; first; ability to adjust configuration and size to fit new conditions; proficiency; principle in software architecture where a single instance of the software runs on a server, serving multiple client-organization; immediately; profit.

### 4. Match the beginnings (1-9) to the endings (a-i) to make definitions of the words in bold.

- 1) A **proponent** is
- 2) To **replace**
- 3) When a company **outsources**
- 4) **Infrastructure** is
- 5) When a company becomes liable for something unpleasant or undesirable,
- 6) **Upfront** payment is
- 7) **Uptime** is
- 8) If a company distributes something according to a plan or set apart for a special purpose,
- 9) When you **evolve**,
  - a) a person who favors a particular idea or proposal.
  - b) means to substitute a person or a thing for.
  - c) it turns to outside suppliers or manufacturers; contract workers from outside of a company to perform specific tasks instead of using company employees.
  - d) foundation, basis, substructure, underlying features of an operation.
  - e) it **incurs** troubles.
  - f) made in advance, ahead of time.
  - g) a period when something is functional and available for use.
  - h) it **allocates** it.
  - i) you develop, gradually change or mature over time.

5. Underline the key words in the sentences (in exercise 4) which summarize the meaning of the prefixes (they are underlined).

*Look at the prefixes below and try to explain their meanings.*

*Pseudo-, anti-, mal-, trans-, per-, de-, bi-, dia-, em-, hemi-, co-/com-/con-, uni-, ambi-, circum-, fore-, intra-, inter-, un-*

Choose 3-5 prefixes that you would like to remember and make at least five words with each of them.

6. Complete the words in the following sentences with an appropriate prefix from exercise 5.

- In addition, ...communicating ...encrypted over the in-band network leaves the management ...actions open and ...secure.
- Last month computer ...time cost the company over €10000 in lost production.
- Business clients based on these processors are built for the needs of business and engineered to protect their data with new levels of ...formance and ...precedented ...bedded security technologies ...bined into a single high-...formance, secure business tool.
- Software applications may not be ...patible with all operating systems.
- Many companies distribute internal documents on their own ...net.

7. Complete the text with the following words.

*Performance, peer-to-peer (2), tools, complementary, multiple, physical (3), variety, solution, calculation, resources, virtual, clusters (3), single (2), scheduling, grid.*

What is Grid Computing?

The idea behind grid is to make ... machines that may be in different ... locations, behave like they are one large ... machine. A ... of technologies are used to make this happen. ... of machines can be used to increase the ... available at one ... location but to go beyond that requires using ... communications ... and the internet to allow ... of machines at different ... locations to work together. Grid computing is precisely that, you have a ... .. process that uses ... communication to control multiple ... of machines at different locations. A compute cluster refers to a technology that allows a calculation to be done using ... CPUs at a ... site. This is normally done to improve ... by making more CPUs available for doing a      The

clustering technology can be used independently or it can be used as a component part of a ... . The technologies are      , a good starting point for someone who wants

to use these technologies is to focus on using the clustering technology first and then to migrate to a distributed at a later point.

8. While working in ICT sphere you come across many abbreviations. Check if you remember some of them from the previous two units.

*SLA, SaaS, PaaS, IaaS, CPU.*

Try to guess what these abbreviations stand for.

API, PPP, MIDI, IEEE, VPN, DLL, URL, MMOS, VCL, P2P, OLE, CCU

Using dictionary find ten more IT abbreviations.

**9.** Discuss the questions below.

1. What will be the best definition of grid computing?
2. Did grid computing evolve from cloud computing?
3. In which situations is grid computing more preferable over cloud computing? What is the target application for both of them?
4. Provide examples of companies using cloud computing and those using grid computing.
5. What components are necessary to form a grid?

**10.** Make a written translation of the text paying special attention to the terms related to grid computing.

In the simplest of grid systems, the user may select a machine suitable for running his job and then execute a grid command that sends the job to the selected machine. More advanced grid systems would include a job scheduler of some kind that automatically finds the most appropriate machine on which to run any given job that is waiting to be executed. Schedulers react to current availability of resources on the grid. The term scheduling is not to be confused with reservation of resources in advance to improve the quality of service. Sometimes the term resource broker is used in place of scheduler, but this term implies that some sort of bartering capability is factored into scheduling. In a scavenging grid system, any machine that becomes idle would typically report its idle status to the grid management node. This management node would assign to this idle machine the next job whose requirements are satisfied by the machine's resources. Scavenging is usually implemented in a way that is unobtrusive to the normal machine user. If the machine becomes busy with local non-grid work, the grid job is usually suspended or delayed. This situation creates somewhat unpredictable completion times for grid jobs, although it is not disruptive to those machines donating resources to the grid. Grid applications that run in scavenging mode often mark themselves at the operating system's lowest priority level. In this way, they only run when no other work is pending. Due to the performance of modern day

processors and operating system scheduling algor, the grid application can run for as short as a few milliseconds, even between a user's keystrokes.

## **5. Порядок выполнения работы**

Выполнить задания , изучить материал

## 6. Содержание отчета

конспект

### Практическое занятие 10. Современные технологии коммуникации.

**1. Цель работы:** Развитие монологической речи, умение подготовить высказывание по теме “Современные технологии коммуникации.”

**2. Задачи работы:**

- ввести лексические единицы по теме “Современные технологии коммуникации.”
- освоить составление монологического высказывания по теме “Современные технологии коммуникации.”, используя необходимые лексические единицы
- освоить навыки составления презентаций

**3. Подготовка к работе**

Повторение слов по теме “Современные технологии коммуникации.”

#### WHAT IS A COMPUTER?

A computer is a machine with an intricate network of electronic circuits that operate switches or magnetize tiny metal cores. The switches, like the cores, are capable of being in one or two possible states, that is, on or off; magnetized or demagnetized. The machine is capable of storing and manipulating numbers, letters, and characters (symbols).

The basic idea of a computer is that we can make the machine do what we want by inputting signals that turn certain switches on and turn others off, or magnetize or do not magnetize the cores.

The basic job of computers is processing of information. For this reason computers can be defined as devices which accept information in the form of instructions, called a program, and characters, called data, perform mathematical and/or logical operations on the information, and then supply results of these operations. The program, or part of it, which tells the computers what to do and the data, which provide the information needed to solve the problem, are kept inside the computer in a place called memory.

It is considered that computers have many remarkable powers. However, most computers, whether large or small, have three basic capabilities.

First, computers have circuits for performing arithmetic operations, such as: addition, subtraction, division, multiplication and exponentiation.

Second, computers have a means of communicating with the user. After all, if we couldn't feed information in and get results back, these machines wouldn't be of much use. Some of the most common methods of inputting information are to use terminals, diskettes, disks and magnetic tapes. The computer's input device (a disk drive or tape drive) reads the information into the computer. For outputting information two common devices used are: a printer, printing the new information on paper, and a cathode-ray-tube display, which shows the results on a TV-like screen.

Third, computers have circuits which can make decisions. The kinds of decisions which computer circuits can make are not of the type: "Who would win the war between two countries?" or "Who is the richest person in the world?" Unfortunately, the computer can only decide three things, namely: Is one number less than another? Are two numbers equal? And, Is one number greater than another?

A computer can solve a series of problems and make thousands of logical decisions without becoming tired. It can find the solution to a problem in a fraction of the time it takes a human being to do the job.

A computer can replace people in dull, routine tasks, but it works according to the instructions given to it. There are times when a computer seems to operate like a mechanical 'brain', but its achievements are limited by the minds of human beings. A computer cannot do anything unless a person tells it what to do and gives it the necessary information; but because electric pulses can move at the speed of light, a computer can carry out great numbers of arithmetic-logical operations almost instantaneously. A person can do the same, but in many cases that person would be dead long before the job was finished.

**Study the vocabulary. Put down the following words into your notebooks:**

intricate – сложный, запутанный;

electronic circuit – электронная цепь/схема;

to operate switches – приводить в действие переключатели;

to store numbers – запоминать числа;

to manipulate – управлять/преобразовывать;

to input / to feed in – вводить (информацию);

to turn on = to switch on – включать;

to turn off = to switch off – выключать;

to process data – обрабатывать данные;

to supply – вводить/обеспечивать;

addition [s'dɪfɪn] – сложение;

subtraction – вычитание;

division – деление;

multiplication – умножение;

exponentiation – возведение в степень;

user – пользователь;



input device – устройство ввода;

disk drive – дисковое запоминающее устройство, дисковод;

tape drive – запоминающее устройство на магнитной ленте;

cathode-ray tube – электроннолучевая трубка;

to make decisions – принимать решения;

instantaneously – мгновенно.

**Answer the following questions according to the text:**

What is a computer?

What are the main functions of a computer?

In what way can we make the computer do what we want?

What is the basic task of a computer?

In what form does a computer accept information?

What is a program?

What are data?

What is memory?

What three basic capabilities have computers?

What is the function of an input device?

What devices are used for outputting information?

What decisions can the computer make?

**Find English equivalents in the text and put it down:**

сложная сеть электронных цепей;

приводить в действие;

хранить (запоминать) числа;

обрабатывать символы;

размагничивать сердечники;  
обработка информации;  
символы, называемые данными;  
выполнять математические операции;  
сложение, вычитание, деление, умножение;  
возведение в степень;  
устройство ввода;  
дисковод;  
нудная рутинная работа;  
электрические импульсы.

#### **4. Порядок выполнения работы**

Выполнить задания , изучить материал

#### **5. Содержание отчета**

конспект

## Практическое занятие 11. Интернет

- 1. Цель работы:** Развитие монологической речи, умение подготовить высказывание по теме “ Интернет ”
- 2. Задачи работы:**
  - ввести лексические единицы по теме “ Интернет ”
  - освоить составление монологического высказывания по теме “ Интернет ”, используя необходимые лексические единицы
  - освоить навыки составления презентаций
- 3. Подготовка к работе**  
Повторение слов по теме “ Интернет ”

Прочитайте текст

1) Internet is a global network connecting millions of computers. Each Internet computer, called a *host*, is independent. Its operators can choose which Internet services to use.

It is a system of Internet servers that support specially formatted documents. The documents are formatted in a *markup language called HTML (Hyper Text Markup Language)* that supports links to other documents, as well as graphics, audio, and video files. This means you can jump from one document to another simply by clicking the mouse button.

2) What is the difference between the Internet and the World Wide Web? The Internet and the Web are two separate but related things.

The *Internet* connects millions of computers together globally, forming a network in which any computer can communicate with any other computer as long as they are both connected to the Internet. Information travels over the Internet in many languages known as protocols.

3) The *World Wide Web*, or simply *Web* is built on top of the Internet. The Web also utilizes browsers, such as Internet Explorer, to access Web documents called Web pages. Web documents also contain graphics, sounds, text and video. The Web is just one of the ways that information can be sent and received over the Internet. Internet is used for e-mail, not the Web. So the Web is just a portion of the Internet, but the two terms should not be confused.

4) Tim Berners-Lee (born in 1955) invented the World Wide Web. His first version of the Web was a program named "Enquire". He invented the system as a way of sharing scientific data (and other information) around the world, using the Internet, a world-wide network of computers and hypertext documents. He wrote the language HTML (HyperText Mark-up Language), the basic language for the Web, and devised URL's (universal resource locators) to designate the location of each web page. HTTP (Hyper Text Transfer Protocol) was his set of rules for linking to pages on the Web. Berners-Lee is now a Principal Research Scientist at the Laboratory for Computer Science at MIT (Massachusetts Institute of Technology)

**Words:**

global network - глобальная сеть

to link - соединять, связывать

exchange - обмен

host - хост (компьютер, подключенный к сети Интернет)

to gain, get access - получить доступ

remote terminal - дистанционный (удаленный) терминал

server – сервер

formatted - форматированный

hypertext document - гипертекстовый документ

markup - разметка документа в HTML-формате

HTML (HyperText Markup Language)- язык HTML (стандартный язык, используемый для создания страниц WWW)

URL(Universal Resource Locator)- универсальный указатель информационного ресурса (стандартизованная строка символов, указывающая местонахождение документа в сети Internet)

application - приложение, прикладная программа

browser (Web browser) - Web-браузер (программа для просмотра Web-страниц в сети Internet)

1. Найдите заголовок к каждому абзацу 1) – 4)

1. What Is World Wide Web?

1) Who Invented the World Wide Web?

2) What Is Internet?

3) What Is the Difference between Internet and World Wide Web

2. Ответьте на вопросы.

5) What is Internet?

6) What is World Wide Web?

7) What is HTML?

8) What is used for e-mails?

9) Are World Wide Web and Internet the same?

10) Who invented World Wide Web?

11) What is URL?

12) What is HTTP?

### **13) Порядок выполнения работы**

Выполнить задания , изучить материал

### **14) Содержание отчета**

конспект

## **Практическое занятие 12. Всемирная сеть**

1. **Цель работы:** Развитие монологической речи, умение подготовить высказывание по теме “предпосылки для успешной карьеры в сфере информационной безопасности”

2. **Задачи работы:**

- ввести лексические единицы по теме “ Всемирная сеть ”
- освоить составление монологического высказывания по теме “ Всемирная сеть ”, используя необходимые лексические единицы
- освоить навыки составления презентаций

3. **Подготовка к работе**

Повторение слов по теме “ Всемирная сеть ”

4. **Задание**

## SYSTEM

Computer can be divided into three main types, depending on their size and power.

Mainframe computers are the largest and most powerful. They can handle large amounts of information very quickly and can be used by many people at the same time. They usually fill a whole room and are sometimes referred to as mainframes or computer installations. They are found in large institutions like universities and government departments.

Minicomputers, commonly known as minis, are smaller and less powerful than mainframes. They are about the size of an office desk and are usually found in banks and offices. They are becoming less popular as microcomputers improve.

Microcomputers, commonly known as micros, are the smallest and least powerful. They are about the size of a typewriter. They can handle smaller amounts of information at a time and are slower than the other two types. They are ideal for use as home computers and are also used in education and business. More powerful microcomputers are gradually being produced; therefore they are becoming the most commonly used type of computers.

A computer can do very little until it is given some information. This is known as the input and usually consists of program and some data.

A program is a set of instructions, written in a special computer language, telling the computer what operations and processes have to be carried out and in what order they should be done. Data, however, is the particular information that has to be processed by the computer, [e.g. numbers](#), names, measurements. Data brought out of the computer is known as the output.

When a program is put into operation, the computer executes the program step by step to process the data. The same program can be used with different sets of data.

Information in the form of programs and data is called software, but the pieces of equipment making up the computer system are known as hardware.

The most important item of hardware is the CPU (Central Processing Unit). This is the electronic unit at the center of the computer system. It contains the processor and the main memory.

The processor is the brain of the computer. It does all the processing and controls all the other devices in the computer system.

The main memory is the part of the computer where programs and data being used by the processor can be stored. However it only stores information while the computer is switched on and it has a limited capacity. All the other devices in the computer system, which can be connected to the CPU, are known as peripherals. These include input devices, output devices and storage devices.

An input device is a peripheral, which enables information to be fed into the computer. The most commonly used input device is a keyboard, similar to a typewriter keyboard.

An output device is a peripheral, which enables information to be brought out of the computer, usually to display the processed data. The most commonly used output device is a specially adapted television known as a monitor or VDU (Visual Display Unit). Another common output device is a printer. This prints the output of the CPU onto paper.

A storage device is a peripheral used for the permanent storage of information. It has a much greater capacity than the main memory and commonly uses magnetic tape or magnetic disks as the storage medium.

These are the main pieces of hardware of any computer system whether a small "micro" or a large mainframe system.

### Vocabulary

divide into – разделить

depend on – зависеть от

size – размер

mainframe computer – универсальная вычислительная машина

powerful – мощный  
handle – обрабатывать  
fill – занимать  
referred to – относиться к  
installations – системы  
institution – организация  
Government departments – государственные учреждения  
minicomputer – мини-ЭВМ  
microcomputers – микро-ЭВМ  
typewriter – печатная машинка  
commonly know – широко известный  
input – вводная информация  
data – данные  
a set of – набор  
carry out – выполнять  
to be processed by – обрабатываться  
measurements – измерения  
brought out – выдает  
output – производительность  
capacity – производительность  
put into operation – запустить  
execute – выполнять  
software – программное обеспечение  
pieces of equipment – единица оборудования  
hardware – аппаратное оборудование  
item – элемент  
Central Processing Unit – центральный процессор  
contain – включать в себя  
main memory – оперативная память  
brain – мозг  
store information – хранить информацию  
switch on – включать  
limited capacity – ограниченные возможности  
peripherals – второстепенное оборудование  
input device – вводное устройство  
lead into – вводить  
keyboard – клавиатура  
output device – выводное устройство  
display the processed data – отображать на дисплее получ. данные  
storage device – запоминающее устройство  
permanent – длительное хранение  
magnetic tape – магнитная лента  
storage medium – носитель информации  
mainframe system – универсальная система

**Answer the following questions:**

What type of computer is most suitable for home use?  
What is a program?  
What are the functions of main memory, input device and storage device?  
What data is?  
What are the functions of processor and output device?  
What are peripherals?

What is hardware?

What is software?

What are the main types of computers?

**Match each component in column A with its function in column B:**

storage device

input device

output device

main memory

processor

displays the processed data

it holds the programs and data being used by the processor

it does all the processing and controls the peripherals

it allows data to be entered

it provides permanent storage for programs and data

**Complete the table:**

	Mainframe	Minicomputer	Microcomputer
Size			
Power			
Use			

**Find the English equivalents for these word combinations:**

Самый важный элемент аппаратного оборудования; запоминающее устройство – это второстепенное оборудование; одна и та же программа может использоваться с разными данными; компьютерная система; размером с печатную машинку, зависит от размера и мощности, самый широко распространенный, хранить информацию, вводная информация.

**4. Порядок выполнения работы**

Выполнить задания , изучить материал

**5. Содержание отчета**

конспект

7 семестр

Практическое занятие 1. ПРЕДПОСЫЛКИ ДЛЯ УСПЕШНОЙ КАРЬЕРЫ

- 1. Цель работы:** Развитие монологической речи, умение подготовить высказывание по теме “предпосылки для успешной карьеры в сфере информационной безопасности”
- 2. Задачи работы:**
  - ввести лексические единицы по теме “карьера”
  - освоить составление монологического высказывания по теме “карьера”, используя необходимые лексические единицы

- освоить навыки составления презентаций

### 3. Подготовка к работе

Повторение слов по теме “Карьера в сфере информационной безопасности”

### 4. Задание

1. How do you see your future profession? Please answer the following questions:

1) What kind of work are you interested in?

- a) well paid ;
- b) interesting ;
- c) in a large and famous company ;
- d) quiet ;
- e) in an industry which has a future ;
- f) prestigious
- g) not to sit the whole day in the office ;
- h) to travel a lot ...

2) What position would you like to have?

- a) to manage people — manager
- b) to work for someone else — an employee
- c) to be your own boss — self-employed, businessman
- d) be responsible for everything — top manager, director
- e) to work for the state — state employee

2. Communicate with your classmate about applying for a job, using active vocabulary:

a promotion – продвижение по службе

a responsibility - обязанность

to apply for a new job – претендовать на какую – либо должность

resume – резюме

to look for a new job (work, position) – искать новую работу

to employ – нанимать на работу

an employer – наймодатель

skilled worker – квалифицированный рабочий

experienced worker – опытный работник

a salary – зарплата, оклад

a bonus – премии

a trial period – испытательный срок

to earn – зарабатывать

to join the company – поступать на работу в компанию

to have extra work – подрабатывать

to work overtime – работать сверхурочно

to work in shifts – работать по сменам

well-paid, prestigious job – высокооплачиваемая престижная работа

3. Read the text and translate it:

Working His Way Up

Nick Minelli has been a help-desk technician for a year. Working as a help-desk technician



was a good beginning for Nick. By doing his job well, he knew he could get a promotion. He has done his job well and has shown that he is responsible and trustworthy.

Recently Nick's supervisor suggested that he started training as a junior information security analyst. That was great news because Nick suddenly felt closer to his real goal – becoming Senior Cybersecurity Risk Analyst. Through a combination of hard work, patience and determination Nick planned to work his way up the Ladder of success.

His new position gave Nick the opportunity to make more money. He did his best to be noticed by his supervisor. Establishing threat plans and protocols, maintaining data, monitoring security network access, performing tests and risk analysis will be Nick's responsibilities if he gets promoted to a junior information security analyst.

Becoming Senior Cybersecurity Risk Analyst would be like a dream come true for Nick. He believes that hard work and determination will pay off.

4. Find the English equivalents to the following words:

Хорошо выполнять свою работу; получить повышение по службе; начать учиться; упорный труд, терпение и решительность; вверх по лестнице успеха; получить должность.

5. In pairs decide what you need to do to achieve your dream job. Write the list of skills you need to obtain and what responsibilities you will have.

6. Present it to a class.

#### 4. Порядок выполнения работы

Ответить на вопросы; обсудить вопрос в парах, используя целевой язык; прочитать и перевести текст; в парах подготовить доклад; презентовать доклад группе

#### 5. Содержание отчета

Презентация доклада

ДЗ - [7] стр 124 упр 10

## Практическое занятие 2. ПРОДОЛЖИТЬ УЧЕБУ ИЛИ ПОЙТИ РАБОТАТЬ? ПРОГРАММЫ ОБМЕНА.

1. **Цель работы:** Развитие диалогической речи, овладение различными видами диалога по теме “Продолжить учебу или пойти работать”

#### 2. Задачи работы:

- совершенствование навыков составления монологического высказывания по теме “учеба и работа”
- совершенствование навыков диалогической речи
- совершенствование навыков полного понимания высказывания собеседника

#### 3. Подготовка к работе

Повторение слов по теме “Образование” и “Карьера в сфере информационной безопасности”

#### 4. Задание

1. Talk about two of the topics below.

- jobs you have done in your life
- a job you wanted to have when you were young
- qualities a person needs to do the job you currently have
- changes you expect to occur in your career in the future

2. Read the quotes and explain what you think they mean. Then, say whether any of them applies to your experience.

- “A job is not just a job, it’s who you are.” (Jude Law, actor) “Most people work just hard enough not to get fired and get paid just enough money not to quit.” (George Carlin, comedian)
- “The best preparation for good work tomorrow is to do good work today.” (Elbert Hubbard, writer)
- “It’s never too late to be what you might have been.” (George Eliot, writer)

3. Work in groups. 1st group discusses pros of going to work after college and cons of getting postgrad education, 2nd group discusses pros of getting postgrad education and cons of going to work after college

4. Play debate

5. Watch a video and write down all the advantages and disadvantages of these two ways <https://www.investopedia.com/financial-edge/0511/work-experience-vs.-education-which-lands-you-the-best-job.aspx>

6. Discuss in pairs your future career steps

#### 6. Порядок выполнения работы

Ответить на вопросы; обсудить цитаты, используя целевой язык; выполнить задание в группах; дебаты; посмотреть видео; выполнить задание; обсудить, изменилось ли их мнение после просмотра видео; ответить на вопрос в парах, используя целевой язык

#### 7. Содержание отчета

Результаты дебатов

ДЗ [7] стр 46-47 упр 1-3

### Практическое занятие 3. ЗАПОЛНЕНИЕ АНКЕТЫ АБИТУРИЕНТА.

**1. Цель работы:** Развитие коммуникативных умений письма. Умение письменно оформить анкету абитуриента

**2. Задачи работы:**

- совершенствование навыков диалогической речи
- освоение навыков заполнения формы абитуриента

- освоение навыков составления презентации
- совершенствование навыков самопроверки

### 3. Подготовка к работе

Повторение слов по теме “Образование” и “Карьера в сфере информационной безопасности”, “Характер человека”.

### 4. Задание

**Part 1: Write a three-page double-spaced, well-constructed response to the following questions:**

1. Why do you want to pursue a Cybersecurity major at our College?
2. Describe a recent cyber-attack in the news, whether or not you believe it was handled well by the victim company, and why.
3. What qualities and interests would you bring to the Cybersecurity program at our College?
4. Describe the importance of ethics and morals in the field of Cybersecurity – how would you personally approach the study and practice of this field given your talents and gifts?

**Part 2: Create a 10-15 minute presentation (you can use Microsoft PowerPoint, Google Presentation or Prezi) discussing and highlighting questions 1-4 above:**

1. Be creative and have fun doing it. Here is an example of what your presentation could possibly look like:  
<https://www.youtube.com/watch?v=6uKy0UCXuFE>
2. It is also acceptable to create a screencast presentation similar to this:  
<http://screencast-o-matic.com/watch/c2nI0xnl7W>

**Self-Assessment Checklist: Please ensure you can attest to the two statements below.**

1. I have created a document that is grammatically correct and free of spelling errors (Part 1) and describes and answers questions 1-4. While I may have consulted and received guidance from others, I attest I wrote this document on my own.
2. I have created a presentation (Part 2) that discusses highlights of questions 1-4. While I may have sought assistance from friends and/or family members, I attest I performed the majority of the work necessary to create the presentation.

### 8. Порядок выполнения работы

Письменно ответить на вопросы, презентация, проведение саморефлексии

### 9. Содержание отчета

Презентация по теме

ДЗ [1] стр 82-83 упр 1-4

## Практическое занятие 4. РАБОТА В БОЛЬШОЙ КОМПАНИИ ИЛИ ФРИЛАНС: ПЛЮСЫ И МИНУСЫ.

**1. Цель работы:** Развитие умений чтения с извлечением необходимой информации

### 2. Задачи работы:

- совершенствование навыков составления монологического высказывания по теме “работа”
- совершенствование навыков диалогической речи
- совершенствование навыков понимания основного содержания письменного текста

- совершенствование навыков поиска необходимой информации в тексте

### 3. Подготовка к работе

Повторение слов по теме “Карьера в сфере информационной безопасности”

### 4. Задание

1. Who is a freelancer? Give a definition.
2. Read the blogpost

#### **The future of work in cyber security. Is it freelance?**

Recently, I've been talking a lot about the future of work.

The reason why is because it's changing. And, whether it's freelance or not, you'd better be ready. I believe we're entering the next revolution and a break with the past as significant as that in the late 18th and 19th centuries.

Technology is transforming everything, particularly the way we work. We can see it in what we do, where we do it, how we do it and when we do it. We're working longer hours, communicating with more people, in different countries via more “tools” and the workplace is rapidly seeping into our homes. The boundaries are blurring.

In cyber security we see this before most as we're securing these new technologies and ways of working. We are lucky.

When the industrial revolution began it transformed many people's lives. As time went on confidence grew. This enabled freedom. Freedom to be creative, and as a result, innovation began to thrive.

Structures changed too and became hierarchical. Workers were devalued. They became a cog in the wheel, just like the components of the machines they were operating.

Today, this is being reversed.

We're now seeing collaboration, connection, individualism and specialised mastery. Creativity is being valued. More people are aware of their worth, and are fed up with being fear driven. They're choosing to work on their terms and many are entering the world as entrepreneurs, freelancers or contractors.

As a result, large companies are breaking down or rapidly trying to adopt new, improved cultures to keep them. All of a sudden they're interested in the happiness of their workers because they know that if they don't adjust their ways, revenues will fall and their future will be at risk.

So, back to my post headline – the future of cyber security work. Is it freelance?

Is it the end of big teams, hierarchical management, offices and commutes? Are people loyal to their art and skill, not to their employer? Is the future of our work freelance?

I believe it is.

The rules of business have changed and just like a network, we need to operate together. No one element is more important than the other. Now, we each have a place and the ability to decide how we work, when we work and with whom we work.

Employers don't want big permanent teams any more. They want optimisation and the ability to measure results. Production is moving up a gear.

They want flexibility, agility and the opportunity to expand and contract fast. They want a dynamic and intelligent approach. They don't want to be paying for holidays, sickness, maternity, paternity leave etc.

Workers want flexibility. They want to be involved in more enjoyable, meaningful work. They want to work full-time, part-time, flexitime and have more options on the table. Mothers want to be able to work and be there for their children. Fathers want this too.

This is why I believe that the future of work is changing. It's freelance. And, I believe that the best way to respond to this is through project based work, a very specific brief and seeking specialised skills that are readily available in the global market.

3. Answer the questions:
  - What is the author's opinion?
  - What makes her think that?

- What are the advantages of freelance?
- 4. In groups write the advantages and disadvantages of both working in the company and working freelance.
- 5. Discuss the advantages and disadvantages together.
- 6. Discuss in pairs what you would choose for yourself and why.

### 10. Порядок выполнения работы

Ответить на вопрос, прочитать и перевести текст, выделить и записать новые слова, ответить на вопросы по тексту, выполнить задание в группах, фронтальное обсуждение

### 11. Содержание отчета

Плюсы и минусы работы в компании и фриланса

ДЗ [1] стр 162 упр 2

## Практическое занятие 5. РАБОТА МОЕЙ МЕЧТЫ.

**1. Цель работы:** Совершенствование коммуникативных умений письма. Умение письменно передать информацию в виде эссе

### 2. Задачи работы:

- совершенствование навыков частичного понимания устного высказывания
- совершенствование навыков диалогической речи
- освоение навыков заполнения составления письменно-речевого произведения с элементами рассуждения по теме “Работа моей мечты”

### 3. Подготовка к работе

Повторение слов по теме “Карьера в сфере информационной безопасности”

### 4. Задание

1. Create a mind-map of things that are included in a cybersecurity job.
2. Discuss the pros and cons of working in cybersecurity..
3. Watch a video <https://youtu.be/ASzBncCX2wA>
4. Discuss why these people work in cybersecurity.
5. Write an essay “Why I want to work in cybersecurity”

### 12. Порядок выполнения работы

Создание диаграммы связей (фронтальная работа), обсуждение плюсов и минусов работы, просмотр видео, выполнение задания по видео, написание эссе

### 13. Содержание отчета

Эссе

ДЗ [7] стр 124 упр 10

## Практическое занятие 6. ОПЫТ БЫВШЕГО СТУДЕНТА.

**1. Цель работы:** Развитие навыков аудирования, восприятия на слух информации и точного понимания содержания

**2. Задачи работы:**

- совершенствование навыков составления монологического высказывания по теме “учеба и работа”
- совершенствование навыков диалогической речи
- совершенствование навыков частичного и полного понимания устного высказывания

**3. Подготовка к работе**

Повторение слов по теме “Образование” и “Карьера в сфере информационной безопасности”

**4. Задание**

1. Discuss with a partner what questions you can ask a graduate about his studying experience and about his current position.

**2. Listening**

John is 24 and he is a recent graduate. He's just been appointed as a trainee field engineer with an American oil services company.

The interview is in three parts: The job, Qualifications and training, Work placement

### **Part 1 The job**

As you listen, answer these questions:

1. How long has John had this job?
  - a. a few months
  - b. three months
  - c. two months
  - d. six months
2. What does he have to find out about when an oil company is drilling?
  - a. the rock
  - b. the oil
  - c. the sea
  - d. the drill
3. What kind of data do the sensors provide?
  - a. the depth of the hole
  - b. the resistivity of the rock
  - c. the quantity of oil
  - d. the hardness of the rock
4. Where has he been working most recently?
  - a. on-shore (on land)
  - b. on an oil tanker
  - c. off-shore (at sea)
  - d. in a laboratory
5. What is a 'dog house'?
  - a. a laboratory
  - b. a computer
  - c. a winch

- d. a workshop

### **3. Part 2. Qualifications and training**

2. What degree does he have?
  - a. Master's in Electronics
  - b. a Bachelor's in Electronics
  - c. a Master's in Electrical
  - d. a Master's in Electronics
3. How many trainees did the company appoint
  - a. ten
  - b. eight
  - c. eighty
  - d. eighteen
4. What does the company provide for all trainees?
  - a. training for a degree
  - b. work placements
  - c. a three-month course
  - d. off-shore work
5. What did he like most about his study?
  - a. his work placement
  - b. being in Glasgow
  - c. working flat out
  - d. getting a holiday job in Germany

### **4. Part 3 Work placement**

1. How long was his work placement?
2. Where was it?
3. What did the company make?
4. Were all his workmates German?
5. What language training did he have for his placement?

5. Discuss with your groupmates what education you need to get to become a good specialist. How long do you need to study? Do you need to attend any special courses?

#### **14. Порядок выполнения работы**

Обсуждение в парах, аудирование, проверка ответов, обсуждение в группах

#### **15. Содержание отчета**

Конспект, ответы на вопросы по аудированию

ДЗ [1] стр 136 упр 1

## Практическое занятие 7. ПРОФЕССИИ В ОБЛАСТИ ИНФОРМАЦИОННЫХ ТЕХНОЛОГИЙ.

1. **Цель работы:** Развитие и совершенствование умений чтения с извлечением необходимой информации

## 2. Задачи работы:

- ввести лексические единицы по теме “карьера”
- совершенствование навыков понимания основного содержания письменного текста
- совершенствование навыков поиска необходимой информации в тексте
- совершенствование навыков диалогической речи

## 3. Подготовка к работе

Повторение слов по теме “Карьера в сфере информационной безопасности”

## 4. Задание

1. Think about jobs in computing and try to describe them. What qualities, characteristics, education and training he/she should have?

Which is the most important in your opinion?

2. Complete these definitions with jobs from the list.

software engineer  
computer security specialist

blog administrator  
help desk technician

DTP operator  
hardware engineer  
network administrator  
webmaster

1. A \_\_\_\_\_ designs and develops IT devices.
2. A \_\_\_\_\_ writes computer programs.
3. A \_\_\_\_\_ edits and deletes posts made by contributors to a blog.
4. A \_\_\_\_\_ uses page layout software to prepare electronic files for publication.
5. A \_\_\_\_\_ manages the hardware and software that comprise a network.
6. A \_\_\_\_\_ designs and maintains websites.
7. A \_\_\_\_\_ works with companies to build secure computer systems.
8. A \_\_\_\_\_ helps end-users with their computer problems in person, by email or over the phone.

3. Read the two job advertisements.

- DIGITUM-UK SENIOR PROGRAMMER required by DIGITUM-UK, a leading supplier of business systems to the insurance industry.

You will be able to work on the full range of software development activities — analysis, design, coding, testing, debugging and implementation.

At least two years' experience of COBOL or C++ is necessary.

As we are active in Europe, fluency in French, Italian or another European language is desirable.

Don't miss this opportunity to learn new skills and develop your career.

Send your CV to CHRIS SCOTT, PERSONNEL MANAGER. DIG-ITUM-UK, 75 PARKSHILL STREET, LONDON SW14 3DE



- DTP operator required for a leading financial magazine.

We are looking for a bright, competent QuarkXPress operator with at least three years' experience in design and layout. Skills in Photoshop, Freehand or Illustrator are an advantage.

Ability to work in a team and to tight deadlines is vital.

Please apply in writing, with CV and samples of your work, to Tom Parker, Production Manager, Financial Monthly, Stockton Street, London EC1A 4WW.

4. Tick (V) the most important qualities and abilities (1-10) for each job. Add more to the list you can. Which three things do you think are most important for each job?

	Senior programmer	DTP operator
1. logical reasoning		
2. patience and tenacity		
3. being good with figures		
4. imagination		
5. self-discipline		
6. accuracy		
7. leadership skills		
8. efficiency		
9. creativity		
10. drawing skills		

5. Look at the profile for Charles Brown. Which of the jobs above is most appropriate for him? Give your reasons.

Charles Brown 23 years old

Professional summary

I graduated in 2004 with A Levels in English, Art and Maths, and went on to do a course in graphic design and page layout at Highland Art School.

Since 2006 I've been a graphic designer for PromoPrint, a company specializing in publishing catalogues and promotional material, and have used Adobe InDesign and other DTP software.

6. Discuss if you would like to apply for one of the jobs. Give reasons for your answers.

### 16. Порядок выполнения работы

Обсуждение ответов на заданные вопросы, выполнение задания, чтение текста, выполнение заданий по тексту, обсуждение

### 17. Содержание отчета

Конспект

ДЗ [4] стр 116 упр 5

## Практическое занятие 8. ОБЪЯВЛЕНИЕ О ПРИЕМЕ НА РАБОТУ.

**1. Цель работы:** Развитие и совершенствование умений чтения с извлечением необходимой информации

### 2. Задачи работы:

- ввести новые лексические единицы по теме “карьера в сфере информационной безопасности”
- совершенствование навыков понимания основного содержания письменного текста
- совершенствование навыков поиска необходимой информации в тексте
- совершенствование навыков диалогической речи

### 3. Подготовка к работе

Повторение слов по теме “Карьера в сфере информационной безопасности”

### 4. Задание

1. What requirements do you need to meet to become a cybersecurity specialist? Make a list.
2. In groups read the following job offers. Then do the mingling activity telling other groups about the requirements and key responsibilities of the jobs. Range the jobs from the entry level to the senior level.

Jr Security Analyst

Remote  
Full-time

\$67.9K - \$86K a year.

Full Job Description

The Security Analyst is responsible for all activities related to designing, selecting, implementing, and maintaining security controls for major information systems, including achieving and sustaining authorization to operate following NIST Risk Management Framework procedures and guidance mandated under FISMA.

## Key Responsibilities

- Analyze systems, data, and operating environments to find appropriate security controls.
- Work closely with project team members to make sure that applicable security requirements are incorporated in systems
- Participate in business, technical, and security reviews of the solution to explain selected security and privacy controls
- Perform initial and ongoing risk assessments of the system
- Creation and maintenance of security documentation

## Required Qualifications

- Bachelor's Degree +2 - 4 years of experience
- Provides task unique functional expertise necessary to interpret requirements, ensure responsiveness and achieve successful performance
- Possess demonstrated knowledge in designated field or discipline

## Associate - Cyber Threat Intelligence Analyst

Hybrid remote

\$62,500 - \$92,500 a year

The Cyber Threat Intelligence Analyst is a junior role in the Threat Intelligence team reporting to the Threat Intelligence Team Lead. The Cyber Threat Intelligence Analyst collects, analyzes, and produces intelligence using the Intelligence Process and Structured Analytic Techniques to identify emergent cyber threats.

### Responsibilities:

- Develops reports on relevant cyber threats – reports go to senior analysts and the Cyber Threat Intelligence Team Lead
- Correlates threat data from various sources and analyzes network events to establish the identity and modus operandi of malicious users active
- Works closely with other technical and incident management personnel to develop a fuller understanding of the intent, objectives, and activity of cyber threat actors
- Coordinates with technology and business groups to assess, implement, and monitor IT-related security risks.
- Provides briefings and presentations to leadership
- Operates within established standards, processes and procedures
- Conducts research and evaluation of technical and all-source intelligence

### Qualifications:

- Bachelor's degree preferred; areas of study: Computer Science, Cybersecurity, Intelligence, National Security
- 0-2 years of relevant experience
- Familiar with modern cyber threats and the tools network defenders use to counter them
- Experience in a technical cybersecurity role strongly preferred
- Ability to automate routine tasks through scripting (python, powershell, etc.) is beneficial but not required
- Proficient in Microsoft Office tools

- Strong written and verbal communication skills with the ability to develop relationships with key stakeholders
- Team player
- Willingness to learn and be challenged to grow as a cyber professional

## Senior-Cybersecurity

\$115,600 - \$192,600 a year  
Full-time

### Full Job Description

#### Duties:

Collaborate to gather and review software requirements/user stories, create software design specifications, and collaborate with engineers and architects to assess and test hardware and software interactions.

Transfer business requirements to technical aspects and communicate to customers.

Design, develop and implement large scale applications using modern technology.

Execute a specific development methodology through application of various programming languages.

Perform dynamic application security testing, interface testing, end-to-end testing and user acceptance testing.

Utilize Java, Spring framework, JWE, JPA, SQL, LDAP, MicroServices, Kubemeters, REST API, Angular and Angular JS, Java Script, HTML/Bootstrap and AJSC. Performing Azure, Cassandra, Linux, APM tools, GIT, MAVEN and IDE.

#### MINIMUM REQUIREMENTS:

Requires a Master's degree in Computer Science or Computer Engineering and 3 years of experience utilizing Java, Spring framework, JWE, JPA, SQL, LDAP, MicroServices, Kubemeters, REST API, Angular and Angular JS, Java Script, HTML/Bootstrap and AJSC; and performing Azure, Cassandra, Linux, APM tools, GIT, MAVEN and IDE.

3. Discuss what job you would like to get in the future

### 18. Порядок выполнения работы

Обсуждение вопроса, чтение и перевод текстов в группах, пересказ информации другим группам, выполнение задания, ответ на вопрос.

### 19. Содержание отчета

Конспект

ДЗ [4] стр 116 упр 6

## Практическое занятие 9. СОСТАВЛЕНИЕ РЕЗЮМЕ.

1. **Цель работы:** Совершенствование навыков письма. Умение письменно оформить информацию в виде резюме.
2. **Задачи работы:**

- ввести лексические единицы по теме “прием на работу”
- совершенствование навыков понимания основного содержания письменного текста
- совершенствование навыков поиска необходимой информации в тексте
- освоение навыков написания резюме

### 3. Подготовка к работе

Повторение слов по теме “Карьера в сфере информационной безопасности”

#### 4. Задание

1. What mistakes on a CV do you think might stop someone from getting a job?
2. Match the following words with their correct definitions.

1. a recruiter
2. an employer
3. a candidate
4. an agency
5. a buzzword
6. a salary
7. a survey

- a. a business that provides services for companies and people
- b. a company or a person that looks for people to employ
- c. a company or a person that pays somebody to work for them
- d. a fixed amount of money that a person earns every month or year
- e. a person that is competing for a job
- f. a set of questions that are asked to get information
- g. a word that has become very popular in a particular subject area

### 3. Reading

**You are going to read an article about the unusual mistakes that people make on their CVs. Match the headings to the paragraphs in the article on the next page.**

Non-editable formats / Salary details / Ridiculous email address / Too many keywords / Bad file names / Not doing your research / Statements that you can't prove

The 7 unusual CV mistakes that can cost you the job Adapted from the Independent

It's common knowledge that you can lose a job even before the interview if you have too many spelling mistakes on a CV. But now, recruiters have reported the biggest mistakes that might stop you from getting that job.

An employer has to form a first impression of you so your CV is very important. Just one mistake can seriously damage your chances of getting a job interview, say Stand Out CV, a UK CV writing service.

After doing a survey with over 50 different recruiters across the UK, the agency said that candidates with badly named files or those who include their current pay and salary requirements on their CV are less likely to be selected for interviews.

Andrew Fennel, director at StandOutCV, said that candidates should think about what employers want to see on a CV and also how this information should be presented.

Here are the seven unusual mistakes:

\_\_\_\_\_ 1

Candidates try to "beat the system" by using as many buzzwords as possible in their CVs. But the survey said that this is a bad idea.

Recruiters advise candidates to write their CVs to impress humans first, and to make sure that they only include \_\_\_\_\_ keywords \_\_\_\_\_ once.

\_\_\_\_\_ 2

Recruiters might need to make quick edits to your CV before sending it to hiring managers. So, if your CV isn't editable, recruiters will need to get in touch with you to obtain another version.

This will slow down the process, and other candidates' CVs will reach the people that make the decisions before yours, the survey said.

\_\_\_\_\_ 3

Make sure your CV file name looks professional as it may be the first thing recruiters and employers see.

Saving your CV with a name like "Dave's\_first\_CV\_draft\_553.doc" does not make the candidate look very reliable, the survey discovered.

\_\_\_\_\_ 4

Recruiters advise candidates to stick to the facts like experience and your skills or achievements.

Avoid phrases such as "Best salesman in Europe" or "World famous industry expert".

\_\_\_\_\_ 5

One of the biggest mistakes that a candidate can make with their CV is not finding out what qualities their potential employer is looking for before they write it.

\_\_\_\_\_ 6

Including your current pay or the salary you want on your CV might hurt your ability to negotiate for the offer you want.

\_\_\_\_\_ 7

An email address such as "bad-boy-4-life@gmail.com" will make you look "extremely unprofessional". If you have doubts, recruiters advise you to set up a new email address.

*Adapted from The Independent 31st March 2016, By Zlata Rodionova*

**4. Read the text again and put 'T' (True) or 'F' (False) next to each statement below.**

1. It's okay to have spelling mistakes on your CV.
2. Job candidates should try to put themselves in their employer's shoes.
3. The agency did a survey with more than 50 people that hire job candidates.
4. Putting a lot of buzzwords in your CV will impress your employer.
5. You should protect your CV by sending it in a non-editable format.
6. You should always set up a new email address when applying for jobs.

### 5. Find a word or phrase in the text which means ...

1. something that most people know:
2. make a mental picture about a person when you meet them for the first time:
3. things that are needed:
4. trusted to behave or work properly:
5. things that you have completed which are difficult to do:
6. discuss something to reach a formal agreement:

### 6. Discuss any of the questions below.

1. Which do you think is the best piece of advice? Which is the worst piece of advice? Why?
2. Do you have to look at other people's CVs as part of your job? If so, have people made any of these mistakes and did it stop you giving them an interview?
3. Do you think that employers are right not to interview people because of these mistakes? Why/why not?

## 20. Порядок выполнения работы

Выполнить задания, прочитать и перевести текст, выполнить задания после текста. Написать драфт резюме

## 21. Содержание отчета

Резюме

ДЗ [1] стр 165 упр 6

## Практическое занятие 10. СОСТАВЛЕНИЕ СОПРОВОДИТЕЛЬНОГО ПИСЬМА.

**1. Цель работы:** Совершенствование навыков письма. Умение письменно оформить и передать информацию в виде сопроводительного письма.

**2. Задачи работы:**

- ввести лексические единицы по теме “прием на работу”
- освоение навыков написания сопроводительного письма

**3. Подготовка к работе**

Повторение слов по теме “Карьера в сфере информационной безопасности”, “Резюме”

**4. Задание**

### 1. Preparation

1. Based on the job announcement key words and what you know about the job, what is the company looking for in a candidate? (What are they buying? What problem are they trying to solve? What experience, results, skills, approach, and abilities do they need?)
2. To whom are you sending the letter?

Name:

Title:

Company, Address:

## **2. Opening Paragraph**

1. What is the exact title of the job?
2. How did you discover the job was available? (e.g., job board, internet, placement center, professional meeting, referral, person in hiring firm, career fair, recruiter, etc.)
3. Why are you interested in this particular job and company? (e.g., type of work, location, reputation, opportunities, etc.)

## **3. Middle Paragraph**

1. What do you have that matches those needs? (Experience, education, results, skills, approach, abilities)
2. Matching cont....
3. Determine the three to five areas that are the highest priority to the company. 1. 2. 3. 4. 5.
4. Create a few short statements that include key words from job description. Use power verbs. Show impact and scope.

## **4. Closing Paragraph**

1. What do you want to happen after you send the resume? (An interview, a phone call, an email, etc.)
2. What is the person expecting you to send? (e.g., resume, letter of interest, salary requirements, references, examples of your work)
3. What next steps will you take after sending your resume? (e.g., a call, email, a visit)

## **5. Contact Information**

1. What is your phone and email?

## **22. Порядок выполнения работы**

Выполнение заданий в парах и мини группах, написание сопроводительного письма по пунктам

## **23. Содержание отчета**

Сопроводительное письмо

ДЗ [1] стр 167-168 упр 2

## **Практическое занятие 11. ПРОХОЖДЕНИЕ СОБЕСЕДОВАНИЯ**

1. **Цель работы:** Развитие диалогической речи, овладение навыками ведения диалога во время собеседования



## 2. Задачи работы:

- ввести лексические единицы по теме “личные качества и умения”
- совершенствование навыков составления монологического высказывания по теме “личные качества и умения”
- совершенствование навыков диалогической речи
- совершенствование навыков полного и частичного понимания высказывания собеседника

## 3. Подготовка к работе

Повторение слов по теме “Карьера в сфере информационной безопасности”, “Резюме”, “Личные качества”

## 4. Задание

### 1. Read the sentences below and match them to the character traits. What traits are important for the job that you want?

1. Mike doesn't mind stress. In fact, it helps him to work better.
2. Julie is always sitting at her desk when everybody else arrives in the office.
3. Julio wants to be chairman of his company one day.
4. Dave hardly ever makes mistakes. He double-checks all his calculations.
5. Bettie keeps making the same silly mistakes. For example, she often misspells clients' names in her emails.
6. Carlo always supports his colleagues and accepts their advice.
  - able to work in a team
  - able to work under pressure
  - ambitious
  - careful
  - careless
  - punctual

### 2. Job interview advice

Look at the list. Do you think they are good or bad things to say in an interview? Put 'G' (Good) or 'B' (Bad) next to each sentence.

1. I'm looking for new challenges
2. I'm really nervous.
3. How much will I earn?
4. In the short-term I want to develop my sales skills and gain more experience in selling.
5. My weakness is that I work too hard.
6. I really need this job!
7. I work quite well under pressure. I find it very motivating.
8. My current boss is horrible.
9. No, I don't have any questions for you.
10. I love the idea of free snacks on Fridays!

## 3. Reading

Now complete the text below with statements from Exercise 2.

Never say these things in a job interview Here are 7 things you should never say in a job interview:

\_\_\_\_\_ 1

If you don't know your potential salary, you shouldn't ask about it too early in the interview. If you do this, the interviewer will think you are only interested in money and nothing else. Employers want people who are a good match for the position that they are offering. Salary negotiations should wait till the end of the interview.

2

Companies do not want to hire someone who doesn't have any confidence. So, it's not always good to be honest. If you are nervous, you should try not to show it.

3

If the interviewer asks about your weaknesses, you should not reply with a standard response that sounds like a hidden strength. Experienced interviewers know this trick. Instead, tell the employer about a real weakness, but a weakness that isn't so important for the job.

4

Don't mention how much you like some of the company's benefits, such as free snacks. The interviewer will think that you do not care about the success of the company.

5

Try not to show that you are desperate for the job. Desperation is a sign of weakness.

6

Never criticize a former boss or company. It's not classy, and it will make you sound negative.

7

When the interviewer asks if you have any questions, don't say "no." This makes you look unprepared for the interview or not interested in the job or company.

#### 4 Do you agree with the advice in the article?

#### 5 Look at the typical interview questions below. Listen to the dialogue and tick the ones that you hear.

How would you describe yourself?  
Could you tell me who you work for at the moment?  
How long have you been working for ...?  
Why do you want to work for this company? Why are you leaving your job?  
What can you offer our company?  
You know this job requires a lot of travel. Is that a problem for you?  
Have you had any experience in ...?  
What are your goals for the future? What is your greatest weakness? How do you cope with pressure? What are your salary requirements?

#### 6 Checking understanding

Listen again and choose the best answer for each question below:

1. How long has Kate been working for KP Lewis?

- a. 3 years
- b. 4 years
- c. 8 years

2. How long has she been working in the accounting department?

- a. 8 months
- b. maybe
- c. 3 months

3. Why is she leaving her job?

- a. She is not well-paid.
- b. She can't use all her skills.
- c. Her boss is horrible.
4. Is traveling a problem for her?
- a. yes
- b. 4 months
- b. no
5. Why was she successful as a sales representative for a language school?
- a. The school increased its profit.
- b. The school sold more books.
- c. The school increased registrations.
6. What are her short-term goals for the future?
- a. She wants to buy a house.
- b. She wants to develop her sales skills.
- c. She wants to become a manager.
7. What are her long-term goals?
- a. She wants to obtain a high position in a company.
- b. She wants to start her own business.
- c. She wants to work for a school.
8. What is her greatest weakness?
- a. She works too hard.
- b. She's a perfectionist.
- c. She makes appointments at the last minute.
9. What motivates her to focus on her work?
- a. team work
- b. pressure
- c. a good salary

**7. In pairs, interview each other for a job of your choice. Use questions/expressions from this lesson and any others that you may need. Would you give your partner the job? Why/why not?**

#### **4. Порядок выполнения работы**

Выполнение заданий, чтение и перевод текста, выполнение заданий по тексту, проведение собеседования в парах

#### **5. Содержание отчета**

Конспект

ДЗ [1] стр 170 упр 5

## Практическое занятие 12. ВЫСТУПЛЕНИЕ НА КОНФЕРЕНЦИИ, ВЕДЕНИЕ ДИАЛОГА

**1. Цель работы:** Развитие монологической и диалогической речи, овладение навыками ведения диалога на рабочем месте

**2. Задачи работы:**

- ввести лексические единицы по теме “вводные фразы, фразы согласия/несогласия”
- освоить навык ведения диалогов по теме “разговор на рабочем месте”, используя необходимые лексические единицы
- совершенствование навыков полного понимания высказывания собеседника

**3. Подготовка к работе**

Повторение вводных фраз, фраз согласия/несогласия

**4. Задание**

1. Think about which subjects are appropriate to discuss in your country with friends, family, and work colleagues. Complete the table with a Y if the subject is appropriate, or an N if it is not.

Subject	Friends	Family	Work Colleagues
Politics			
Religion			
Children			
Food			
Weather			
Health			

2. Which subjects do you mostly talk about with each of the above groups of people?

3. What typical topics do you discuss with your colleagues at business meetings?

4. Read the questions and answers below. Then, listen to an extract from a discussion about a company's financial situation. Choose the best answer for each question.

1. What problem is the company facing?

- clients are paying late

- clients are buying from a cheaper competitor
  - employees want higher salaries
2. Which of the measures below does the speaker NOT propose?
    - imposing penalties
    - hiring a credit controller
    - offering cheaper prices
  3. According to the speaker, it's possible that the company's clients will find the proposed measures ...
    - rather strict
    - acceptable
    - flexible
  4. Why does the speaker think that clients will probably accept the proposed measures in the end?
    - they have no choice
    - they have good relationships with the company
    - competitors are more expensive

5. Now listen to a discussion on the prison system and do the same.

1. What problem is the speaker discussing?

- a. too many people are sent to prison
- b. not enough criminals are sent to prison

2. After they are released, most ex-prisoners ...

- a. stop committing crimes
- b. continue to commit crimes

3. According to the speaker, teenagers should be given ...

- a. lighter punishments
- b. longer sentences
- c. more entertainment

4. People who commit very serious crimes should ...

- a. stay in prison for the maximum period of
- b. receive education and training time

6. Read the two discussions and study how the underlined words and expressions are used to structure the arguments:

### **A company's financial problems**

As regards our cash flow situation, we are having problems with slow payers. Therefore, I think we need to deal with this situation urgently. In the first place, we should consider imposing penalties for late payments. For example, if a client pays 10 days late, they would have to pay a fixed amount of interest on the due payment. What's more, we should call our clients more often to insist on prompt payment. In fact, I think we should hire a credit controller responsible for collecting late payments rather than leaving this task to the accountant. I realise that our clients may find these measures rather strict, but if we explain to them carefully and tactfully that these

steps are very necessary, they should understand. After all, we do have very good relationships with them, and we have given most of them generous discounts this year.

### The prison system

I believe that too many people who break the law are sent to prison these days. On the whole, the system doesn't work. Although studies show that most ex-prisoners continue to commit crimes after they are released, more and more people are being imprisoned. The system can be improved in so many ways. Teenagers, for instance, should be given lighter punishments - at least for less serious offences. In addition, education and training should be improved. In other words, we should prepare prisoners for life outside jail. However, regarding very serious crimes, I think that we have no choice but to keep such criminals in jail for the maximum period of time.

7. The underlined words and expressions serve different functions. Study the table on the next page.

<b>Introducing a new topic:</b>	As regards (our cash flow situation), regarding (very serious crimes),
<b>Giving or adding a new point:</b>	In the first place, What's more In addition,
<b>Describing a general situation:</b>	On the whole,
<b>Giving an example:</b>	For example, For instance,
<b>Introducing a contrasting idea:</b>	However, Although
<b>Modifying a previous statement:</b>	In fact,
<b>Simplifying a previous point:</b>	In other words,
<b>Supporting a previous point:</b>	After all,
<b>Introducing the logical result of a situation:</b>	Therefore,

8. Add the following expressions to the table:

**As far as .... is/are concerned, In short, Overall, Firstly, Actually, despite this, Additionally, As a result, In general,**

9. Now complete the discussion on the next page with suitable words and expressions.

### International outsourcing

*On the whole* , I think that outsourcing is a good thing for companies. For many firms, outsourcing work to cheaper regions of the world is one way of reducing costs. The cost of labour in India, \_\_\_\_\_ 2, is much lower than in the West, so many western companies have set up call centres there and are able to provide a cheaper service to their customers.

\_\_\_\_\_ 3, there are plenty of advantages.

\_\_\_\_\_ 4, there are also several drawbacks for companies that outsource. \_\_\_\_\_ 5, they lack full control over the work since they have to trust other companies to train and manage the staff. \_\_\_\_\_ 6, cultural differences mean that customers don't always receive a high standard of service.

\_\_\_\_\_ 7 the countries where outsourcing projects are based, much needed jobs are provided and the local economy usually benefits. \_\_\_\_\_ 8, there is always the risk of exploitation - many workers are paid too little and have to work long hours. \_\_\_\_\_ 9, the conditions under which they work are far from ideal and many suffer from stress.

10. Complete the table with the following expressions:

**Absolutely!**

**I'd go along with that.**

**I'm not sure about that.**

**That might be true, but ...**

**You must be joking!**

**I absolutely disagree.**

**I'm afraid, I don't really agree.**

**I totally agree with you.**

**Yes, you're right.**

**You're right to a certain extent, but ...**

<b>STRONG AGREEMENT</b>	
<b>AGREEMENT</b>	I agree.
<b>PARTIAL AGREEMENT</b>	I agree with you up to a point, but ...
<b>DISAGREEMENT</b>	

<b>STRONG DISAGREEMENT</b>	
--------------------------------	--

**11. In pairs, agree or disagree to the following opinions using expressions from this exercise:**

1. Outsourcing is a good thing for companies and economies.
2. Smoking should be banned everywhere.
3. The best way to learn a language is to live in the country where it is spoken.
4. If you want to get a good job, experience and qualifications are very important.
5. You can never trust salesmen.
6. It is easier to speak English on the phone than face-to-face.
7. People who drink and drive should receive lighter punishments.
8. Spam is irritating.
9. If you want to be a successful businessman, you need to be born with certain character traits.
10. You should never mix business with pleasure.

**12. Work in small groups. Choose a topic from the list below. Have a discussion and respond to opinions using expressions from this lesson.**

1. The efficiency of the public transport system in your town.
2. The most effective way to attract new customers.
3. The best ways for people and governments to deal with the financial crisis.
4. The advantages/disadvantages of using mobile phones on planes.
5. The advantages/disadvantages of budget airlines.
6. The importance of doing business in English.

**4. Порядок выполнения работы**

Выполнить задания для понимания употребления вводных фраз, прослушать аудио и выполнить задания на аудирование, выполнить задания по тексту, обсуждение в мини-группах с использованием новых фраз

**5. Содержание отчета**

Конспект

ДЗ [1] стр 169 упр 4

**Практическое занятие 13. ЧТЕНИЕ И ПЕРЕВОД ТЕКСТОВ. МОНОЛОГИЧЕСКАЯ,  
ДИАЛОГИЧЕСКАЯ РЕЧЬ**

**1. Цель работы:** Развитие монологической и диалогической речи, овладение навыками ведения диалога на рабочем месте

**2. Задачи работы:**

- ввести лексические единицы по теме “информационная безопасность”
- совершенствовать навык ведения диалога по теме “информационная безопасность”, используя необходимые лексические единицы
- совершенствовать навыки частичного и полного понимания устного высказывания



### 3. Подготовка к работе

Повторение вводных фраз, фраз согласия/несогласия, повторение слов по теме “Информационная безопасность”

### 4. Задание

#### 1. Data Protection Discussion

1. What is data protection? Why is it important?
2. How do you ensure your own personal data is protected?
3. What personal information may be collected by companies (either from customers or staff)?
4. How do companies ensure this data is kept safe?
5. How could this data be used by criminals?
6. What different cyber threats can you think of?

#### 2. Cybersecurity Vocabulary

- **to encrypt** (verb), **encryption** (noun), **encrypted** (adjective) – *the process to turn data into code to prevent unauthorised access.*
- **(to) hack** (verb, noun), **cyberattack** (noun), **hacker** (noun, person) – *to gain unauthorised access to a computer system; a person who hacks into computer systems.*
- **cybercrime** (noun, concept), **cybercriminal** (noun, person) – *crimes committed using computer systems or the internet; a person who commits cybercrimes.*
- **credit card fraud** (noun) – *fraud committed using the details of another person’s credit card.*
- **ransomware** (noun) – *a computer program, or malware, that infects a computer and encrypts files, in order to secure a ransom in exchange for decrypting the files.*
- **hacktivism** (noun, concept), **hacktivist** (noun, person) – *hacking for social or political purposes.*

3. Using the vocabulary words above, complete the following sentences (remember to use the correct form of the word, e.g. verb conjugation or plural noun)

1. All emails and messages should be \_\_\_\_\_ to prevent confidential information being compromised.
2. \_\_\_\_\_ in the UK in 2020 resulted in losses of £414 million for the banking industry.
3. In 2015, \_\_\_\_\_ from Anonymous revealed the personal details of nearly 1,000 members of the Ku Klux Klan.
4. It was revealed this week that JBS Holdings had paid \$11 million to cybercriminals who had infected their systems with \_\_\_\_\_.
5. Panamanian law firm Mossack Fonseca suffered a \_\_\_\_\_ which resulted in more than 10 million confidential documents being leaked to the public concerning offshore companies.
6. Police forces across the world are having to rethink their strategies to combat \_\_\_\_\_.

#### 4. Cybersecurity vocabulary comprehension questions

1. What kind of files do you need to encrypt at work? How do you do this?
2. Can you think of any notable cyberattacks? What happened? What was the consequence?
3. Have you, or anyone you know, been a victim of cybercrime? Who did/would you report it to?
4. Why are banks reluctant to report credit card fraud to the police?
5. If your system becomes infected with ransomware, is it better to pay the ransom or not?
6. What kind of information or activities might a hacktivist be interested in?

## 6. Video: Quantum Computers & The Future of Cybersecurity

You are going to watch a TED Talk by Craig Costello called “In the war for information, will quantum computers defeat cryptographers?”

**Watch the video here:** <https://yourenglishpal.com/blog/business-english-conversation-lesson-plan-cybersecurity/>

### 7. Watch the video and after, discuss the following questions:

1. How will quantum computers help society in the future? How about businesses?
2. What are your main concerns about quantum computers?
3. Why is it necessary to encrypt communications? What would the risk to your company be if its communications were revealed?
4. Should the use of quantum computers be regulated? If so, who should get to use them?
5. Which governments or organisations would you trust with quantum computing technology? Which governments or organisations wouldn't you trust?
6. Tim Callan, from cybersecurity firm Sectigo, said that quantum computers could result in a ‘quantum apocalypse’. What do you think he meant, and do you agree?

### 8.. Cybersecurity Conversation Questions

1. Do you trust the cloud to keep your company's data safe? Why or why not?
2. Have you received training on cybersecurity at work? If so, what did you learn? If not, do you think this would be a good idea?
3. What kind of software can help keep your computer systems safe?
4. What are the different motivations behind cybercrime?
5. How can cyberattacks lead to a company's reputation being damaged? Can you think of any examples when this happened?
6. Which governments are involved in cyberattacks? How could these attacks affect businesses?
7. Will new technology lead to better cybersecurity in the future, or will this new technology lead to worse cybersecurity? Why?
8. What would happen if all the data in the world were made public? How would this change the world as we know it?

ДЗ [4] стр 110 упр 3

#### 4. Порядок выполнения работы

Обсуждение в группе, выполнение заданий индивидуально, просмотр видео, выполнение заданий по видео, обсуждение в парах

#### 5. Содержание отчета

Конспект

## Практическое занятие 14. ОФИЦИАЛЬНАЯ И НЕОФИЦИАЛЬНАЯ ПЕРЕПИСКА

**1. Цель работы:** Совершенствование навыков письма. Умение письменно оформить и передать информацию в виде неофициального письма.

#### 2. Задачи работы:

- ввести лексические единицы по теме “неофициальное письмо”
- совершенствование навыков понимания основного содержания письменного текста

- совершенствование навыков поиска необходимой информации в тексте
- освоение навыков написания неофициального письма

### 3. Подготовка к работе

Повторение вводных фраз, структуры письма

### 4. Задание

#### 1. Look at the picture below and answer the questions.



1. What kind of holiday are these people having?
2. Where could these people be?
3. What time of year do you think it is?
4. Does this road look easy or difficult?
5. Where do you think they are going to sleep tonight?
6. Have you ever been on this type of holiday? Did/Would you enjoy it? Why/not?

#### 2. Now read the writing task and the notes.

You are planning to spend a week of your summer holiday cycling through England and now you are writing an email to an English friend of yours to ask for some answers to specific questions (140-190 words). Use these notes to help:

- Pretty place?
- No hills!
- Best month?
- Accommodation?

#### 3. Read the model answer on the next page and answer the questions below.

Hi  
 Thanks for your last email! Sorry I haven't been in touch with you for a while, but I've had a really crazy time at work recently! In fact, I need a holiday now, and I'm writing to ask you some questions about cycling in the UK. I'm really getting into cycling around town here, but I'm not very fit, so I'm looking for a beautiful area of England which doesn't have many hills! Can you recommend somewhere that's flat and pretty? I can take my holiday in July or August – when is the weather usually better? I want to avoid the rain, but it's best if the sun isn't too hot. Maybe that's never a big problem in England! How about meeting up while I am in the UK? I'm looking forward to planning this holiday, so write soon with your ideas! Please give your family my

love.  
Love,  
Anna

1. Did the writer cover all four points from the task?
2. Where should the missing point go in the text? Mark the place with an arrow.
3. The missing point could be introduced like this: *Another reason to plan for good weather is that I want to have a go at camping. Is this a terrible idea?*  
Complete this point by putting these words in order, to make a question:  
*accommodation / any / Can / cheap / for me / of / other / recommend / types / you?*

**4. Match the phrasal verbs/verb phrases on the left to the definitions on the right.**

1. be in touch (with someone)
2. get into something
3. look for something
4. have a go at something
5. meet up with someone
6. look forward to something

a. arrange to see a friend, e.g. for a coffee

b. contact someone using phone, email, letter, etc c. search for something you need

d. start and enjoy a new activity or hobby

e. try a new activity or hobby for the first time

f. wait for a specific event in the future with a positive feeling

**5. Talk about these topics using full sentences and the verb phrases in bold:**

- Someone you have been in touch with recently
- Someone you are going to meet up with at the weekend
- An activity you are getting into at the moment
- The next activity you'd like to have a go at
- Where you would look for your keys if you couldn't find them
- Something you are looking forward to doing when you have a holiday or vacation

**6. Why has the writer used an informal style? What other examples of informal language are in this text?**

**7. Choose the best option in each pair for informal style and give or underline examples from the model answer.**

- Use first names only in the greeting and closing/ Use surnames/last names
- Use contractions and other short forms./Avoid contractions and use long forms.
- Use indirect questions/Use direct questions
- Use phrasal verbs./Avoid phrasal verbs.
- Use plenty of passives./Avoid passive forms.
- Make jokes and lighthearted comments./Use more serious language.
- Refer to personal relationships./Avoid referring to personal relationships.
- Use emotional language./Use neutral language.

**8. Now plan and write this informal email task.**

A friend of yours from abroad is planning to spend a week of their holiday with you walking in your country and now you are writing an email to them to suggest some options (140-190 words). Use these notes to help:

- beautiful scenery and interesting history
- medium level of difficulty
- best weather in early autumn
- B&B/hostel accommodation

**9. After writing use this form to check your work – tick each point that you achieve.**

<b>C</b> Content	<ul style="list-style-type: none"> <li>- you wrote about a walking holiday in your country with your friend</li> <li>- you made some suggestions and gave reasons about:               <ul style="list-style-type: none"> <li>- a place with beautiful scenery and interesting history - walks with medium level of difficulty</li> <li>- the month with the best weather</li> <li>- B&amp;B/hostel accommodation</li> </ul> </li> <li>- you wrote 140-190 words</li> </ul>
<b>O</b> Organization and layout	<ul style="list-style-type: none"> <li>- you used a letter format with opening and closing</li> <li>- paragraph 1 explains why you are writing</li> <li>- information is organized into separate and indented paragraphs</li> <li>- the last paragraph contains a closing phrase which refers to the next step in your contact</li> </ul>
<b>A</b> Accuracy and range	<ul style="list-style-type: none"> <li>- you used 3-5 of the verb phrases from the lesson correctly - your language was generally accurate for B2 level</li> </ul>

<p><b>S Style</b></p>	<p>you successfully achieved an informal style by using:</p> <ul style="list-style-type: none"> <li>- appropriate informal greeting and closing - first names only - contractions and short forms</li> <li>- direct questions</li> </ul> <p>you have used one or more of these: - jokes</p> <ul style="list-style-type: none"> <li>- references to personal relationships - emotional language</li> </ul>
<p><b>T effect on the target reader</b></p>	<ul style="list-style-type: none"> <li>- your friend feels informed about the options you are suggesting</li> <li>- your friend feels excited about the holiday</li> </ul>

ДЗ [7] стр 135-136 упр 1

#### **6. Порядок выполнения работы**

Выполнить задания, на основе заданий написать неофициальное письмо

#### **7. Содержание отчета**

Неофициальное письмо

## Практическое занятие 15. ДЕЛОВАЯ ПЕРЕПИСКА. РЕКВИЗИТЫ ДЕЛОВОГО ПИСЬМА

**1. Цель работы:** Совершенствование навыков письма. Умение письменно оформить и передать информацию в виде делового письма.

#### **2. Задачи работы:**

- ввести лексические единицы по теме “деловое письмо”
- совершенствование навыков понимания основного содержания письменного текста
- совершенствование навыков поиска необходимой информации в тексте
- освоение навыков написания делового письма

#### **3. Подготовка к работе**

Повторение вводных фраз, структуры делового письма

#### **4. Задание**

1. What are the reasons to write a business letter?

2. There are many reasons why you may need to write business letters or other correspondence:

- 4. to persuade
- 5. to inform
- 6. to request

7. to express thanks
8. to remind
9. to recommend
10. to apologize
11. to congratulate
12. to reject a proposal or offer
13. to introduce a person or policy
14. to invite or welcome
15. to follow up
16. to formalize decisions

3. Check your understanding of the following business terms

1. Before you seal and send your letter, make sure to **a) indent b) justify c) proofread** it.

2. You will be notified as soon as your registered letter reaches the **a) sender b) recipient c) enclosure** and is signed for.

3. Memos are usually used for **a) internal b) Internet c) public** communications.

4. Set off the list of "Do's and Don'ts" by using **a) postage b) indent c) bullet** points.

5. The envelope indicated that there was **a) a logo b) a margin c) an enclosure** but in fact there was only the letter inside.

6. The **a) tone b) body c) format** of the first paragraph was optimistic, so I wasn't expecting the bad news in the middle.

7. I decided not to interview her because the **a) tone b) heading c) grammar** in her cover letter was very poor.

8. The **a) memo b) email c) receipt** about the meeting was posted on the bulletin board for everyone to read.

9. Our address and phone number are printed on our **a) emails b) memos c) letterhead** and envelope.

10. In block format, you do not need to **a) indent b) proofread c) punctuate** each paragraph.

#### 4. Formatting Business Letters

Block format is the most common format used in business today. With this format, nothing is centred. The sender's address, the recipient's address, the date and all new paragraphs begin at the left margin, like this:

Wicked Wax Co. Ltd

*SENDER'S ADDRESS*

22 Charlton Way

*may be printed company logo and  
address*

London, SE10 8QY

11th January, 2016

*DATE*

Ms. Maggie Jones

*RECIPIENT'S ADDRESS*

Angel Cosmetics Inc.

110 East 25th Street

New York, NY, 10021

USA

Your ref: 123

*RECIPIENT'S REFERENCE (IF ANY)*

Our ref: abc

*SENDER'S REFERENCE (IF ANY)*

Dear Ms. Jones,

*SALUTATION*

Forthcoming Exhibition

*SUBJECT*

First paragraph...

*BODY OF LETTER*

Second paragraph...

Third paragraph...

Yours sincerely,

*CLOSING*



***Morris Howard***

*SIGNATURE (HAND-WRITTEN)*

Morris Howard,

*NAME (TYPED),*

President

*TITLE*

cc: Brian Waldorf

*COPY TO*

Enc: catalogue

*ENCLOSURE*

**5. Are the following statements True or False?**

1. With block format, all new paragraphs are indented.
  2. In business letters a salutation is generally followed by a comma or a colon.
  3. Business letters should be simple and easy to read.
  4. It is advisable to wait a day between writing and sending an important letter.
  5. The date on a business letter should appear after the salutation.
  6. An "Enclosure" note should appear below the typed name of the sender at the end of the letter.
  7. The first paragraph of a business letter should be comprised entirely of "small talk".
  8. Contact suggestions generally appear in the closing paragraph of the letter.
  9. Identifying the audience is one of the first steps in planning a business letter.
  10. It is considered standard formatting to include the recipient's address before the salutation in a business letter.
6. Write your own formal business letter, using a separate piece of paper choosing one of the following situations.

**Situation 1:** You are Head of Human Resources at an international cosmetics company. You have been in touch with an IT Training company about training for some of your staff. You have now received information about the training but need to change some of the details. With a partner, think of what kind of changes you might need to make (for example, the number of people taking the training course). Now underline the phrases and expressions in your own letter and on worksheet 2 which you could incorporate into the letter. Write the letter with your partner.

**Situation 2:** You are organizing a conference for your company's sales representatives from all over the country. You have already booked the hotel where the conference will be held and the sales reps will stay, and have just received a letter of confirmation. However, you need to make some changes to the arrangements. With a partner, think of what kind of changes you might need to make (for example, the number of hotel rooms you need). Now underline the phrases and expressions in your own letter and on worksheet 2 which you could incorporate into the letter. Write the letter with your partner.

**17. Порядок выполнения работы**

Разбор теории, выполнение тестов по пройденному материалу, написание делового письма

**18. Содержание отчета**

Деловое письмо

ДЗ [7] стр 140-143 упр 1,2,3